



collegebatch.com

click to campus

VITEEE 2016 Question Paper

Vellore Institute of Technology Engineering Entrance Examination

Download more VITEEE Previous Year Question Papers: [Click Here](#)

SOLVED PAPER

(memory based)

VITEEE
2016

GENERAL INSTRUCTIONS

- This question paper contains total 125 questions divided into four parts :
Part I : Physics Q. No - 1 to 40
Part II : Chemistry Q. No - 41 to 80
Part III : Mathematics Q. No - 81 to 120
Part IV : English Q. No - 121 to 125
- All questions are multiple choice questions with four options, only one of them is correct.
- For each correct response, the candidate will get 1 mark.
- There is no negative marking for the wrong answer.
- The test is of 2½ hours duration.

PART - I (PHYSICS)

1. The potential energy of a system increases if work is done
 - (a) upon the system by a non conservative force
 - (b) by the system against a conservative force
 - (c) by the system against a non conservative force
 - (d) upon the system by a conservative force
2. In photoelectric effect, initially when energy of electrons emitted is E_0 , de-Broglie wavelength associated with them is λ_0 . Now, energy is doubled then associated de-Broglie wavelength λ' is
 - (a) $\lambda' = \frac{\lambda_0}{\sqrt{2}}$
 - (b) $\lambda' = \sqrt{2}\lambda_0$
 - (c) $\lambda' = \lambda_0$
 - (d) $\lambda' = \frac{\lambda_0}{2}$
3. In Wheatstone bridge, 4 resistors $P = 10\Omega$, $Q = 5\Omega$, $R = 4\Omega$, $S = 4\Omega$ are connected in cyclic order. To ensure no current through galvanometer

- (a) 5Ω resistance is connected in series with Q
 - (b) 4Ω resistance is connected parallel to S
 - (c) 10Ω resistance is connected in series with P
 - (d) 4Ω resistance is connected in series with R
4. In given circuit, $C_1 = C_2 = C_3 = C$ initially. Now, a dielectric slab of dielectric constant $K = \frac{3}{2}$ is inserted in C_2 .

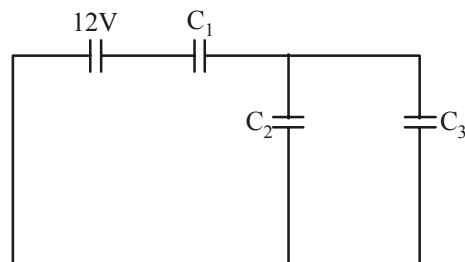

The equivalent capacitance become

- (a) $\frac{5C}{7}$
- (b) $\frac{7C}{5}$
- (c) $\frac{2C}{3}$
- (d) $\frac{C}{2}$

5. If the terminal speed of a sphere of gold (density = 19.5 kg/m^3) is 0.2 m/s in a viscous liquid (density = 1.5 kg/m^3), find the terminal speed of a sphere of silver (density = 10.5 kg/m^3) of the same size in the same liquid

- (a) 0.4 m/s (b) 0.133 m/s
 (c) 0.1 m/s (d) 0.2 m/s

6. In shown fig, the circular loop of wire is moved with velocity towards the infinite current carrying wire. Then

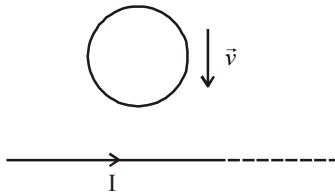

- (a) no current is induced in loop
 (b) current is induced in loop clockwise
 (c) current is induced in loop anticlockwise
 (d) extra charges are induced on the wire loop
7. For a current carrying inductor, emf associated is 20 mV . Now, current through it changes from 6 A to 2 A in 2 s . The coefficient of mutual inductance is
- (a) 20 mH (b) 10 mH
 (c) 1 mH (d) 2 mH
8. A square current carrying loop is changed to a circular loop in time t_1 . Then
- (a) emf is induced in loop for time $t < t_1$
 (b) emf is induced in loop for time $t > t_1$
 (c) no emf is induced in loop during whole process
 (d) emf is induced due to change in magnetic field
9. Hologram is based on phenomenon of
- (a) diffraction
 (b) polarisation
 (c) interference
 (d) total internal reflection
10. In given circuit, all resistances are of 10Ω . Current flowing through ammeter is

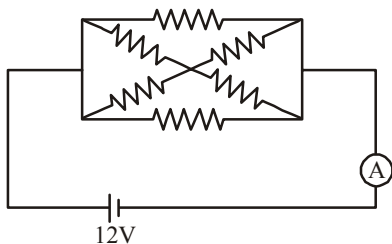

- (a) 3.6 A (b) 1.8 A
 (c) 2 A (d) 1 A
11. The wavelength of an electron for transition from a state n_1 to n_2 is $\frac{9}{8R}$. Which of the following wavelengths is possible for a transition from n_2 to n_1

- (a) $\frac{16}{15R}$ (b) $\frac{4}{3R}$
 (c) $\frac{9}{8R}$ (d) $\frac{36}{5R}$

12. Two solenoids are given – 1st has 1 turn per unit length and 2nd has n turns per unit length. Ratio of magnetic fields at their centres is
- (a) $n : 1$ (b) $1 : n$
 (c) $1 : n^2$ (d) $n^2 : 1$
13. Which statement is correct for the given circuit?

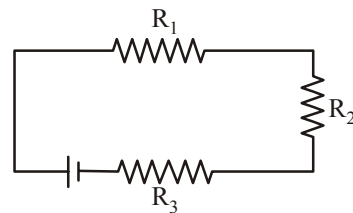

- (a) I through $R_1 > I$ through R_2
 (b) I through $R_3 > I$ through R_2 and R_1
 (c) I through $R_2 > I$ through R_3 and R_1
 (d) I is same in R_1, R_2 and R_3
14. A (+)vely charged particle is placed near an infinitely long straight conductor where there is zero gravity. Then
- (a) the charged particle will not move
 (b) it will move parallel to the straight conductor
 (c) it will move perpendicular to the straight conductor
 (d) it will move with constant acceleration
15. A metallic bar is heated from 0°C to 100°C . The coefficient of linear expansion is 10^{-5} K^{-1} . What will be the percentage increase in length?
- (a) 0.01% (b) 0.1%
 (c) 1% (d) 10%
16. If the wavelength is brought down from 6000 \AA to 4000 \AA in a photoelectric experiment then what will happen?
- (a) The work function of the metal will increase
 (b) The threshold frequency will decrease
 (c) No change will take place
 (d) Cut off voltage will increase

17. For what value of A, B and C, the output Y = 1

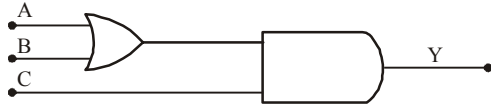

- (a) 0 0 1 (b) 1 0 1
(c) 1 0 0 (d) 0 1 0
18. Let the energy of an emitted photoelectron be E and the wave-length of incident light be λ . What will be the change in E if λ is doubled?
- (a) E (b) $E/2$
(c) $2E$ (d) $E/4$
19. A solid sphere of radius R carries a uniform volume charge density ρ . The magnitude of electric field inside the sphere at a distance r from the centre is
- (a) $\frac{r\rho}{3\epsilon_0}$ (b) $\frac{R\rho}{3\epsilon_0}$
(c) $\frac{R^2\rho}{r\epsilon_0}$ (d) $\frac{R^3\rho}{r^2\epsilon_0}$
20. Two point dipoles $p\hat{k}$ and $\frac{p}{2}\hat{k}$ are located at $(0, 0, 0)$ and $(1\text{m}, 0, 2\text{m})$ respectively. The resultant electric field due to the two dipoles at the point $(1\text{m}, 0, 0)$ is
- (a) $\frac{9p}{32\pi\epsilon_0}\hat{k}$ (b) $\frac{-7p}{32\pi\epsilon_0}\hat{k}$
(c) $\frac{7p}{32\pi\epsilon_0}\hat{k}$ (d) none of these
21. An iron rod of length 2m and cross-sectional area of 50mm^2 stretched by 0.5 mm, when a mass of 250 kg is hung from its lower end. Young's modulus of iron rod is
- (a) $19.6 \times 10^{20}\text{ N/m}^2$
(b) $19.6 \times 10^{18}\text{ N/m}^2$
(c) $19.6 \times 10^{10}\text{ N/m}^2$
(d) $19.6 \times 10^{15}\text{ N/m}^2$
22. Two resistances equal at 0°C with temperature coefficient of resistance α_1 and α_2 joined in series

act as a single resistance in a circuit. The temperature coefficient of their single resistance will be

- (a) $\alpha_1 + \alpha_2$ (b) $\frac{\alpha_1\alpha_2}{\alpha_1 + \alpha_2}$
(c) $\frac{\alpha_1 - \alpha_2}{2}$ (d) $\frac{\alpha_1 + \alpha_2}{2}$
23. The current density varies with radial distance r as $J = ar^2$, in a cylindrical wire of radius R . The current passing through the wire between radial distance $R/3$ and $R/2$ is

- (a) $\frac{65\pi a R^4}{2592}$ (b) $\frac{25\pi a R^4}{72}$
(c) $\frac{65\pi a^2 R^3}{2938}$ (d) $\frac{81\pi a^2 R^4}{144}$
24. A potentiometer circuit shown in the figure is set up to measure emf of cell E . As the point P moves from X to Y , the galvanometer G shows deflection always in one direction, but the deflection decreases continuously until Y is reached. The balance point between X and Y may be obtained by

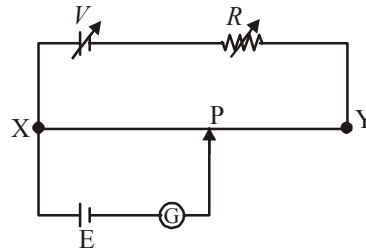

- (a) decreasing the resistance R and decreasing V
(b) decreasing the resistance R and increasing V
(c) increasing the resistance R and increasing V
(d) increasing the resistance R and decreasing V .
25. A current I flows in the anticlockwise direction through a square loop of side a lying in the xoy plane with its center at the origin. The magnetic induction at the center of the square loop is
- (a) $\frac{2\sqrt{2}\mu_0 I}{\pi a}\hat{e}_x$ (b) $\frac{2\sqrt{2}\mu_0 I}{\pi a}\hat{e}_z$
(c) $\frac{2\sqrt{2}\mu_0 I}{\pi a^2}\hat{e}_z$ (d) $\frac{2\sqrt{2}\mu_0 I}{\pi a^2}\hat{e}_x$

26. A particle of charge q and mass m moves in a circular orbit of radius r with angular speed ω . The ratio of the magnitude of its magnetic moment to that of its angular momentum depends on

- (a) ω and q (b) ω, q and m
 (c) q and m (d) ω and m

27. A long straight wire of radius R carries current i . The magnetic field inside the wire at distance r from its centre is expressed as :

- (a) $\left(\frac{\mu_0 i}{\pi R^2}\right) \cdot r$ (b) $\left(\frac{2\mu_0 i}{\pi R^2}\right) \cdot r$
 (c) $\left(\frac{\mu_0 i}{2\pi R^2}\right) \cdot r$ (d) $\left(\frac{\mu_0 i}{2\pi R}\right) \cdot r$

28. If $i_1 = 3 \sin \omega t$ and $i_2 = 4 \cos \omega t$, then i_3 is

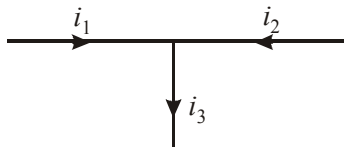

- (a) $5 \sin (\omega t + 53^\circ)$ (b) $5 \sin (\omega t + 37^\circ)$
 (c) $5 \sin (\omega t + 45^\circ)$ (d) $5 \cos (\omega t + 53^\circ)$

29. The equation of AC voltage is $E = 220 \sin (\omega t + \pi / 6)$ and the A.C. current is $I = 10 \sin (\omega t + \pi / 6)$. The average power dissipated is

- (a) 150 W (b) 550 W
 (c) 250 W (d) 50 W

30. The current in an $L-R$ circuit builds up to $(3/4)^{\text{th}}$ of its steady state value in 4 seconds. The time constant of this circuit is

- (a) $\frac{1}{\ln 2}$ sec (b) $\frac{2}{\ln 2}$ sec
 (c) $\frac{3}{\ln 2}$ sec (d) $\frac{4}{\ln 2}$ sec

31. The magnetic flux in a closed circuit of resistance 10Ω varies with time as $\phi = (2t - 4t^2 + 1)$. The current in the loop will change its direction after a time of

- (a) 0.25 sec (b) 0.5 sec
 (c) 1 sec (d) none

32. A fish looking up through the water sees the outside world contained in a circular horizon. If

the refractive index of water is $4/3$ and the fish is 12 cm below the surface, the radius of this circle (in cm) is

- (a) $36\sqrt{5}$ (b) $4\sqrt{5}$
 (c) $36\sqrt{7}$ (d) $36/\sqrt{7}$

33. A metal ball of mass 2 kg moving with a velocity of 36 km/h has a head on collision with a stationary ball of mass 3 kg. If after the collision, the two balls move together, the loss in kinetic energy due to collision is

- (a) 140 J (b) 100 J
 (c) 60 J (d) 40 J

34. Two lenses of focal length $f_1 = 10$ cm and $f_2 = -20$ cm are kept as shown. The resultant power of combination will be

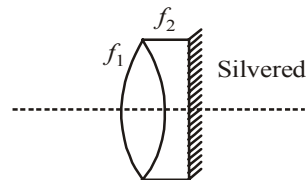

- (a) -10D (b) 5D
 (c) 0 (d) 10D

35. When a plastic thin film of refractive index 1.45 is placed in the path of one of the interfering waves then the central fringe is displaced through width of five fringes. The thickness of the film, if the wavelength of light is 5890\AA , will be

- (a) 6.544×10^{-4} cm (b) 6.544×10^{-4} m
 (c) 6.54×10^{-4} cm (d) 6.5×10^{-4} cm

36. An unpolarised beam of intensity I_0 is incident on a pair of nicols making an angle of 60° with each other. The intensity of light emerging from the pair is

- (a) I_0 (b) $I_0/2$
 (c) $I_0/4$ (d) $I_0/8$

37. The half life of radioactive Radon is 3.8 days.

The time at the end of which $\frac{1}{20}$ th of the radon sample will remain undecayed is (given $\log_{10} e = 0.4343$)

- (a) 3.8 days (b) 16.5 days
 (c) 33 days (d) 76 days.

38. If the nuclear radius of ^{27}Al is 3.6 Fermi, the approximate nuclear radius of ^{64}Cu in Fermi is
 (a) 4.8 (b) 3.6
 (c) 2.4 (d) 1.2
39. A hydrogen atom is in an excited state of principal quantum number (n), it emits a photon of wavelength (λ), when it returns to the ground state. The value of n is
 (a) $\sqrt{\frac{\lambda R}{\lambda R - 1}}$ (b) $\sqrt{\frac{(\lambda R - 1)}{\lambda R}}$
 (c) $\sqrt{\lambda(R-1)}$ (d) $\sqrt{\frac{\lambda R}{\lambda R - 1}}$
40. A marble block of mass 2 kg lying on ice when given a velocity of 6 m/s is stopped by friction in 10 s. Then the coefficient of friction is (Take $g = 10 \text{ ms}^{-2}$)
 (a) 0.06 (b) 0.03
 (c) 0.04 (d) 0.01

PART - II (CHEMISTRY)

41. IUPAC name of valeric acid is
 (a) Propanoic acid (b) Butanoic acid
 (c) Ethanoic acid (d) Pentanoic acid

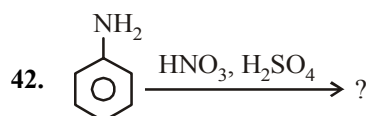

The product P for the above given reaction will be

- (a) *m*-nitroaniline
 (b) *o*-nitroaniline
 (c) *p*-nitroaniline
 (d) both *o* & *p* nitroaniline
43. Coordination number of Co in $[\text{Co}(\text{NH}_3)_6]\text{Cl}_3$
 (a) +2 (b) +3
 (c) +5 (d) +8
44. Which of the following complex will show fac & mer isomerism?
 (a) $[\text{Co}(\text{NH}_3)_3(\text{NO}_2)_3]$
 (b) $[\text{CoCl}_2(\text{en})_2]^+$
 (c) $[(\text{Co}(\text{NH}_3)_3\text{Cl}(\text{en})_2)]^{2+}$
 (d) $[\text{Co}(\text{NH}_3)_2\text{Cl}_2(\text{en})]^+$

45. Which of these undergo polymerisation?

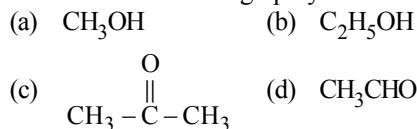

46. Which of the following graph represents variation of 2p-orbital wave function with distance from the nucleus?

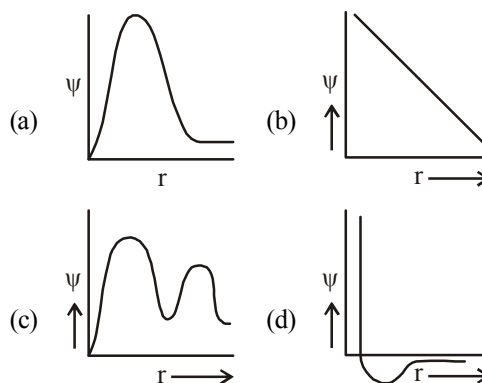

47. Name the catalyst used to bring down the reaction

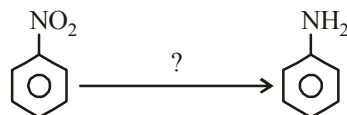

- (a) Sn/HCl (b) CuCl/HCl
 (c) $\text{Cu}_2\text{Cl}_2/\text{HCl}$ (d) $\text{Zn-Hg}/\text{HCl}$
48. The correct set of quantum numbers for Rb (atomic no. 37) is
 (a) $5, 0, 0, -\frac{1}{2}$ (b) $5, 1, 0, \frac{1}{2}$
 (c) $6, 0, 1, \frac{1}{2}$ (d) $5, 1, 1, \frac{1}{2}$
49. XeF_4 disproportionate in water to give
 (a) $\text{Xe} + \text{HF}$ (b) Xe and XeO_3
 (c) XeOF_4 and HF (d) XeO_2Fe and HF
50. An ionic compound has a unit cell consisting of A ions at the corners of a cube and B ions on the centres of the faces of the cube. The empirical formula for this compound would be
 (a) A_3B (b) AB_3
 (c) A_2B (d) AB

51. Among the following the incorrect statement is
- Density of crystals remains unaffected due to Frenkel defect.
 - In BCC unit cell the void space is 32%.
 - Density of crystals decreases due to Schottky defect.
 - Electrical conductivity of semiconductors and metals increases with increase in temperature.

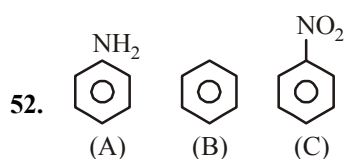

The correct order of electrophilic substitution for the compounds given above will be

- $A > B > C$
 - $C > B > A$
 - $B > C > A$
 - $B > A > C$
53. For mesotartaric acid, the correct configuration for chiral carbon is
- 2R, 3S
 - 2R, 3R
 - 2S, 3R
 - 1D, 2L
54. Which of the two acids form anhydrides?
- (I) Oxalic acid (II) Succinic acid
(III) Benzoic acid (IV) Phthalic acid
- I & III
 - II & IV
 - II & III
 - III & IV
55. By which reaction ketal is formed?
- Glycol with acetone
 - Hydration of glycol
 - Condensation of glycol
 - Glycol with acetaldehyde
56. Which one of the following show stereoisomerism?
- 2-Butene
 - 3-Methyl but-1-ene
 - 2-Methyl butene
 - Butanol
57. Acetophenone and Benzophenone can be distinguished by which of the following test
- Knoevenagel reaction
 - Canizzaro's reaction
 - Aldol condensation
 - HVZ Reaction
58. $R - NC \xrightarrow{LiAlH_4} P$
- The product P in this reaction is

- $R - NH_2$
- $R - \underset{H}{N} - CH_3$
- $R - CH_3$
- $R - N - (CH_3)_2$

59. The protein present in the hair is
- Lysine
 - Myosine
 - Keratin
 - Alanine
60. One mole of an ideal gas at 300 K is expanded isothermally from an initial volume of 1 litre to 10 litres. Then ΔS (cal deg⁻¹ mol⁻¹) for this process is : ($R = 2$ cal K⁻¹ mol⁻¹)
- 7.12
 - 8.314
 - 4.6
 - 3.95
61. For a reaction $A \rightarrow B$; $\Delta H = 20$ kJ mol⁻¹ the activation energy of the forward reaction is 85 kJ/mol. The activation energy of the backward reaction will be
- 105 kJ/mol
 - 65 kJ/mol
 - 45 kJ/mol
 - 75 kJ/mol
62. If the reaction $N_2 + 3H_2 = 2NH_3$ occurs at 200°C and 1000 atm then the graph showing the correct equilibrium yield at 400°C is

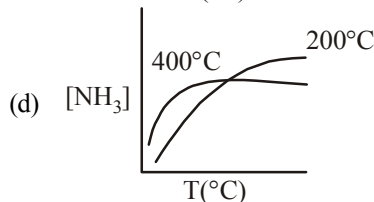
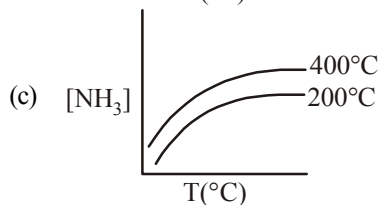
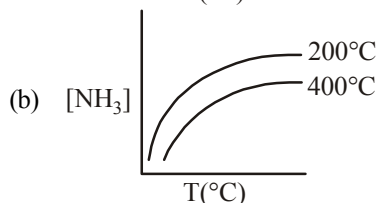
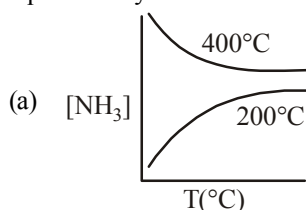

63. Group 15 elements have more electron gain enthalpy than group 16-elements. The correct reason for this is

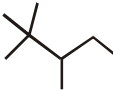
- (a) Half-filled stability of gp. 15 elements.
 (b) Poor shielding in gp. 15
 (c) Poor shielding in gp. 16
 (d) Half-filled stability of gp. 16 elements
64. t-butyl $-\text{CH}=\text{CH}-\underset{\text{O}}{\underset{\parallel}{\text{C}}}-\text{OH}$ can't give decarboxylation while normally α - β unsaturated acid give this reaction because
- (a) t-butyl gp. has large size and does not let the COOH group to leave.
 (b) t-butyl gp. can't extract H from COOH.
 (c) t-butyl gp. stabilise carbanion formed.
 (d) t-butyl gp. does not allow this composition to convert to β - γ -unsaturated acid
65. Which type of carbocation is/are formed when  is treated with an acid?
- (a) 1° (b) 2°
 (c) 3° (d) All the three
66. For hydrogen-oxygen fuel cell, the cell reaction is $2\text{H}_2(\text{g}) + \text{O}_2(\text{g}) \longrightarrow 2\text{H}_2\text{O}(\ell)$
 If $\Delta G_f^\circ(\text{H}_2\text{O}) = -237.2 \text{ kJ mol}^{-1}$, then emf of this cell is
- (a) +2.46 V (b) -2.46 V
 (c) +1.23 V (d) -1.23 V
67. At 298 K, the conductivity of a saturated solution of AgCl in water is $2.6 \times 10^{-6} \text{ S cm}^{-1}$. Its solubility product at 298 K.
- Given: $\lambda^\infty(\text{Ag}^+) = 63.0 \text{ S cm}^2 \text{ mol}^{-1}$,
 $\lambda^\infty(\text{Cl}^-) = 67.0 \text{ S cm}^2 \text{ mol}^{-1}$
- (a) $2.0 \times 10^{-5} \text{ M}^2$ (b) $4.0 \times 10^{-10} \text{ M}^2$
 (c) $4.0 \times 10^{-16} \text{ M}^2$ (d) $2 \times 10^{-8} \text{ M}^2$
68. Standard entropy of X_2 , Y_2 and X Y_3 are 60, 40 and $50 \text{ JK}^{-1} \text{ mol}^{-1}$, respectively. For the reaction, $\frac{1}{2}\text{X}_2 + \frac{3}{2}\text{Y}_2 \rightarrow \text{X Y}_3$, $\Delta H = -30 \text{ kJ}$, to be at equilibrium, the temperature will be
- (a) 1250 K (b) 500 K
 (c) 750 K (d) 1000 K
69. The enthalpy change for a given reaction at 298 K is $-x \text{ J mol}^{-1}$. For the reaction to be spontaneous at 298 K, the entropy change at that temperature
- (a) can be negative, but numerically greater than $\frac{x}{298} \text{ J K}^{-1}$
 (b) can be negative, but numerically smaller than $\frac{x}{298} \text{ J K}^{-1}$.
 (c) can not be negative
 (d) can not be positive
70. a moles of PCl_5 is heated in a closed container to equilibrate $\text{PCl}_5(\text{g}) \rightleftharpoons \text{PCl}_3(\text{g}) + \text{Cl}_2(\text{g})$ at a pressure of P atm. If x moles of PCl_5 dissociate at equilibrium, then
- (a) $\frac{x}{a} = \frac{K_p}{K_p + P}$ (b) $\frac{x}{a} = \left(\frac{K_p + P}{K_p} \right)^{1/2}$
 (c) $\frac{x}{a} = \left(\frac{K_p}{P} \right)^{1/2}$ (d) $\frac{x}{a} = \left(\frac{K_p}{K_p + P} \right)^{1/2}$
71. A plot of $\ln K$ against $\frac{1}{T}$ (abscissa) is expected to be a straight line with intercept on ordinate axis equal to
- (a) $\frac{\Delta S^\circ}{2.303R}$ (b) $\frac{\Delta S^\circ}{R}$
 (c) $-\frac{\Delta S^\circ}{R}$ (d) $R \times \Delta S^\circ$
72. In a reaction $A \rightarrow \text{Products}$, when start is made from $8.0 \times 10^{-2} \text{ M}$ of A , half-life is found to be 120 minute. For the initial concentration $4.0 \times 10^{-2} \text{ M}$, the half-life of the reaction becomes 240 minute. The order of the reaction is:
- (a) zero (b) one
 (c) two (d) 0.5
73. A reaction: $A_2 + B \rightarrow \text{Products}$, involves the following mechanism:
 $A_2 \rightleftharpoons 2A$ (fast)
 (A being the intermediate)
 $A + B \xrightarrow{k_2} \text{Products}$ (slow). The rate law consistent to this mechanism is:
- (a) rate = $k[A_2][B]$ (b) rate = $k[A_2]^2[B]$
 (c) rate = $k[A_2]^{1/2}[B]$ (d) rate = $k[A_2][B]^2$

74. The following data were obtained for a given reaction at 300 K.
- | Reaction | Energy of activation
(kJ mol ⁻¹) |
|-----------------|---|
| (i) uncatalysed | 76 |
| (ii) catalysed | 57 |
- The factor by which rate of catalysed reaction is increased, is
- (a) 21 (b) 2100
(c) 2000 (d) 1200
75. The wave number of the first emission line in the Balmer series of H-Spectrum is :
(R = Rydberg constant) :
- (a) $\frac{5}{36}R$ (b) $\frac{9}{400}R$
(c) $\frac{7}{6}R$ (d) $\frac{3}{4}R$
76. Which one of the following reactions of xenon compounds is not feasible?
- (a) $3\text{XeF}_4 + 6\text{H}_2\text{O} \longrightarrow 2\text{Xe} + \text{XeO}_3 + 12\text{HF} + 1.5\text{O}_2$
(b) $2\text{XeF}_2 + 2\text{H}_2\text{O} \longrightarrow 2\text{Xe} + 4\text{HF} + \text{O}_2$
(c) $\text{XeF}_6 + \text{RbF} \longrightarrow \text{Rb}[\text{XeF}_7]$
(d) $\text{XeO}_3 + 6\text{HF} \longrightarrow \text{XeF}_6 + 3\text{H}_2\text{O}$
77. Anisole is treated with HI under two different conditions.
- $$\text{C} + \text{D} \xleftarrow{\text{HI(g)}} \text{C}_6\text{H}_5\text{OCH}_3 \xrightarrow{\text{conc. HI}} \text{A} + \text{B}$$
- The nature of A to D will be
- (a) A and B are CH₃I and C₆H₅OH, while C and D are CH₃OH and C₆H₅I
(b) A and B are CH₃OH and C₆H₅I, while C and D are CH₃I and C₆H₅OH
(c) Both A and B as well as both C and D are CH₃I and C₆H₅OH
(d) A and B are CH₃I and C₆H₅OH, while there is no reaction in the second case.
78. Phenol undergoes electrophilic substitution more easily than benzene because
- (a) -OH group exhibits +M effect and hence increases the electron density on the *o*- and *p*-positions.
(b) oxocation is more stable than the carbocation
(c) both (a) and (b)
(d) -OH group exhibits acidic character
79. Which of the following name reaction is not used for introducing a -COOH group?
- (a) Cannizzaro reaction
(b) Benzilic acid rearrangement
(c) Baeyer - Villiger oxidation
(d) Iodoform reaction
80. Esterification of acid chloride with ethanol is usually carried out in the presence of pyridine. The function of pyridine is
- (a) to remove HCl formed in the reaction
(b) to react with acid chloride to form an acylpyridinium ion
(c) both (a) and (b)
(d) as a catalyst

PART - III (MATHEMATICS)

81. The solution of the differential equation
- $$(1 + y^2) + (x - e^{\tan^{-1}y}) \frac{dy}{dx} = 0$$
- (a) $(x - 2) = ke^{-\tan^{-1}y}$
(b) $2xe^{\tan^{-1}y} = e^{2\tan^{-1}y} + k$
(c) $xe^{\tan^{-1}y} = \tan^{-1}y + k$
(d) $xe^{2\tan^{-1}y} = e^{\tan^{-1}y} + k$
82. A tetrahedron has vertices at O (0, 0, 0), A (1, 2, 1) B (2, 1, 3) and C (-1, 1, 2). Then the angle between the faces OAB and ABC will be
- (a) 120° (b) $\cos^{-1}\left(\frac{17}{31}\right)$
(c) 30° (d) 90°
83. The foci of the ellipse $\frac{x^2}{16} + \frac{y^2}{b^2} = 1$ and the hyperbola $\frac{x^2}{144} - \frac{y^2}{81} = \frac{1}{25}$ coincide then value of b^2 is
- (a) 1 (b) 5
(c) 7 (d) 9
84. If the tangent to the function $y = f(x)$ at (3,4) makes an angle of $\frac{3\pi}{4}$ with the positive direction of x-axis in anticlockwise direction then $f'(3)$ is

- (a) -1 (b) 1
 (c) $\frac{1}{\sqrt{3}}$ (d) $\sqrt{3}$
85. The probability of India winning a test match against Australia is $\frac{1}{2}$ assuming independence from match to match. The probability that in a match series India's second win occurs at third test match is
 (a) $\frac{1}{8}$ (b) $\frac{1}{4}$ (c) $\frac{1}{2}$ (d) $\frac{2}{3}$
86. If $|\vec{a}| = 3, |\vec{b}| = 2, |\vec{c}| = 1$ then the value of $|\vec{a} \cdot \vec{b} + \vec{b} \cdot \vec{c} + \vec{c} \cdot \vec{a}|$ is (given that $\vec{a} + \vec{b} + \vec{c} = 0$)
 (a) -7 (b) 7
 (c) 14 (d) -14
87. If $f(x) = x^2, g(x) = 2x, 0 \leq x \leq 2$ then the value of $I(x) = \int_0^2 \max(f(x), g(x)) dx$ is
 (a) $\frac{10}{3}$ (b) $\frac{1}{3}$ (c) $\frac{11}{3}$ (d) 32
88. If A and B are matrices and $B = ABA^{-1}$ then the value of $(A + B)(A - B)$ is
 (a) $A^2 + B^2$ (b) $A^2 - B^2$
 (c) $A + B$ (d) $A - B$
89. The value of $(1 + \omega - \omega^2)^7$ is
 (a) $128\omega^2$ (b) $-128\omega^2$
 (c) 128ω (d) -128ω
90. The moment about the point $\hat{i} + 2\hat{j} + 3\hat{k}$ of a force represented by $\hat{i} + \hat{j} + \hat{k}$ acting through the point $2\hat{i} + 3\hat{j} + \hat{k}$ is
 (a) $3\hat{i} + 3\hat{j}$ (b) $3\hat{i} + \hat{j}$
 (c) $-\hat{i} + \hat{j}$ (d) $3\hat{i} - 3\hat{j}$
91. If $g(x)$ is a polynomial satisfying $g(x)g(y) = g(x) + g(y) + g(xy) - 2$ for all real x and y and $g(2) = 5$ then $\lim_{x \rightarrow 3} g(x)$ is
 (a) 9 (b) 10
 (c) 25 (d) 20
92. The equation of one of the common tangents to the parabola $y^2 = 8x$ and $x^2 + y^2 - 12x + 4 = 0$ is
 (a) $y = -x + 2$ (b) $y = x - 2$
 (c) $y = x + 2$ (d) None of these
93. If $e^x = y + \sqrt{1 + y^2}$, then the value of y is
 (a) $\frac{1}{2}(e^x + e^{-x})$ (b) $\frac{1}{2}(e^x - e^{-x})$
 (c) $e^x - e^{-x}$ (d) $e^x + e^{-x}$
94. What is the area of a loop of the curve $r = a \sin 3\theta$?
 (a) $\frac{\pi a^2}{6}$ (b) $\frac{\pi a^2}{8}$
 (c) $\frac{\pi a^2}{12}$ (d) $\frac{\pi a^2}{24}$
95. Convert the hexadecimal numeral ABCD into binary numeral
 (a) $(1010101111001101)_2$
 (b) $(1001000011111111)_2$
 (c) $(1111110000010001)_2$
 (d) $(1000100100111100)_2$
96. The normal at the point $(at_1^2, 2at_1)$ on the parabola, cuts the parabola again at the point whose parameter is
 (a) $t_2 = t_1 - \frac{2}{t_1}$ (b) $t_2 = t_1 + \frac{2}{t_1}$
 (c) $t_2 = -\left(t_1 + \frac{2}{t_1}\right)$ (d) None of these
97. The distance moved by the particle in time t is given by $s = t^3 - 12t^2 + 6t + 8$. At the instant, when its acceleration is zero the velocity is :
 (a) 42 (b) -42
 (c) 48 (d) -48
98. The logical expression X, in its simplest form for the truth table
- | a | b | X |
|---|---|---|
| 1 | 0 | 0 |
| 1 | 1 | 1 |
| 0 | 1 | 0 |
| 0 | 0 | 0 |
- is
 (a) $X = a \cdot b$ (b) $X = a + b$
 (c) $X = a' \cdot b$ (d) $X = a \cdot b'$
99. The value of $\cos\left(\frac{1}{2} \cos^{-1} \frac{1}{8}\right)$ is equal to
 (a) $-\frac{3}{4}$ (b) $\frac{3}{4}$
 (c) $\frac{1}{16}$ (d) $\frac{1}{4}$
100. Consider the objective function $Z = 40x + 50y$. The minimum number of constraints that are required to maximize Z are
 (a) 4 (b) 2
 (c) 3 (d) 1

101. In a culture the bacteria count is 1,00,000. The number is increased by 10% in 2 hours. In how many hours will the count reach 2,00,000 if the rate of growth of bacteria is proportional to the number present.

- (a) $\frac{2}{\log \frac{11}{10}}$ (b) $\frac{2 \log 2}{\log \left(\frac{11}{10}\right)}$
(c) $\frac{\log 2}{\log 11}$ (d) $\frac{\log 2}{\log \left(\frac{11}{10}\right)}$

102. The value of $\sin^{-1} \left(\frac{1}{\sqrt{5}} \right) + \cot^{-1}(3)$ is

- (a) $\frac{\pi}{6}$ (b) $\frac{\pi}{4}$
(c) $\frac{\pi}{3}$ (d) $\frac{\pi}{2}$

103. If $a = \cos 2\alpha + i \sin 2\alpha$, $b = \cos 2\beta + i \sin 2\beta$, $c = \cos 2\gamma + i \sin 2\gamma$ and $d = \cos 2\delta + i \sin 2\delta$, then

$$\sqrt{abcd} + \frac{1}{\sqrt{abcd}} =$$

- (a) $\sqrt{2} \cos (\alpha + \beta + \gamma + \delta)$
(b) $2 \cos (\alpha + \beta + \gamma + \delta)$
(c) $\cos (\alpha + \beta + \gamma + \delta)$
(d) None of these

104. If the mean of a binomial distribution is 25, then its standard deviation lies in the interval

- (a) [0, 5] (b) (0, 5]
(c) [0, 25] (d) (0, 25]

105. Number of ways of selecting three squares on a chessboard so that all the three be on a diagonal line of the board or parallel to it is

- (a) 196 (b) 126
(c) 252 (d) 392

106. If A and B are two matrices such that rank of A = m and rank of B = n, then

- (a) $\text{rank}(AB) = mn$
(b) $\text{rank}(AB) \geq \text{rank}(A)$
(c) $\text{rank}(AB) \geq \text{rank}(B)$
(d) $\text{rank}(AB) \leq \min(\text{rank } A, \text{rank } B)$

107. A variable plane remains at constant distance p from the origin. If it meets coordinate axes at points A, B, C then the locus of the centroid of ΔABC is

- (a) $x^{-2} + y^{-2} + z^{-2} = 9p^{-2}$
(b) $x^{-3} + y^{-3} + z^{-3} = 9p^{-3}$
(c) $x^2 + y^2 + z^2 = 9p^2$
(d) $x^3 + y^3 + z^3 = 9p^3$

108. While shuffling a pack of 52 playing cards, 2 are accidentally dropped. The probability that the missing cards to be of different colours is

- (a) $\frac{29}{52}$ (b) $\frac{1}{2}$ (c) $\frac{26}{51}$ (d) $\frac{27}{51}$

109. Which of the following is INCORRECT for the hyperbola $x^2 - 2y^2 - 2x + 8y - 1 = 0$

- (a) Its eccentricity is $\sqrt{2}$
(b) Length of the transverse axis is $2\sqrt{3}$
(c) Length of the conjugate axis is $2\sqrt{6}$
(d) Latus rectum is $4\sqrt{3}$

110. A box contains 20 identical balls of which 10 are blue and 10 are green. The balls are drawn at random from the box one at a time with replacement. The probability that a blue ball is drawn 4th time on the 7th draw is

- (a) $\frac{27}{32}$ (b) $\frac{5}{64}$ (c) $\frac{5}{32}$ (d) $\frac{1}{2}$

111. The number of common tangents to the circles $x^2 + y^2 - 6x - 14y + 48 = 0$ and $x^2 + y^2 - 6x = 0$ is

- (a) 1 (b) 2
(c) 0 (d) 4

112. The solution of the equation $\cos^2\theta + \sin\theta + 1 = 0$, lies in the interval

- (a) $\left(-\frac{\pi}{4}, \frac{\pi}{4}\right)$ (b) $\left(\frac{\pi}{4}, \frac{3\pi}{4}\right)$
(c) $\left(\frac{3\pi}{4}, \frac{5\pi}{4}\right)$ (d) $\left(\frac{5\pi}{4}, \frac{7\pi}{4}\right)$

113. If $f(x) = (1 + x)^{2/x}$ for $x \neq 0$ and $f(0) = e^2$ is

- (a) left continuous only at $x = 0$
(b) right continuous only at $x = 0$
(c) continuous at $x = 0$
(d) discontinuous at $x = 0$

114. If $y = 2^{x/\ln x}$ then $\frac{dy}{dx}$ at $x = e$ is

- (a) e (b) $2^e \log 2$
(c) $\log 2$ (d) 0

PART - IV (ENGLISH)

115. $\int \frac{1}{x^2(x^4+1)^{3/4}} dx$ is equal to

- (a) $\left(1 + \frac{1}{x^4}\right)^{1/4} + C$ (b) $(x^4 + 1)^{1/4} + C$
 (c) $\left(1 - \frac{1}{x^4}\right)^{1/4} + C$ (d) $-\left(1 + \frac{1}{x^4}\right)^{1/4} + C$

116. If the letters of the word KRISNA are arranged in all possible ways and these words are written out as in a dictionary, then the rank of the word KRISNA is

- (a) 324 (b) 341
 (c) 359 (d) None of these

117. The shortest distance between the lines $x + y + 2 = 6z - 6$ and $x + 1 = 2y = -12z$ is

- (a) $\frac{1}{2}$ (b) 2
 (c) 1 (d) $\frac{3}{2}$

118. The domain and range of the function f given by $f(x) = 2 - |x - 5|$ is

- (a) Domain = R^+ , Range = $(-\infty, 1]$
 (b) Domain = R , Range = $(-\infty, 2]$
 (c) Domain = R , Range = $(-\infty, 2)$
 (d) Domain = R^+ , Range = $(-\infty, 2]$

119. The number of surjective functions from A to B where $A = \{1, 2, 3, 4\}$ and $B = \{a, b\}$ is

- (a) 14 (b) 12
 (c) 2 (d) 15

120. If $f(a+b-x) = f(x)$, then $\int_a^b x f(x) dx$ is

equal to

- (a) $\frac{a+b}{2} \int_a^b f(b-x) dx$
 (b) $\frac{a+b}{2} \int_a^b f(b+x) dx$
 (c) $\frac{b-a}{2} \int_a^b f(x) dx$
 (d) $\frac{a+b}{2} \int_a^b f(x) dx$

Direction (Qs. 121-123) Read the passage carefully and answer the questions given below.

Laws of nature are not commands but statements of acts. The use of the word "law" in this context is rather unfortunate. It would be better to speak of uniformities in nature. This would do away with the elementary fallacy that a law implies a law giver. If a piece of matter does not obey a law of nature it is punished. On the contrary, we say that the law has been incorrectly started.

121. If a piece of matter violates nature's law, it is not punished because

- (a) it is not binding to obey it
 (b) there is no superior being to enforce the law of nature
 (c) it cannot be punished
 (d) it simply means that the facts have not been correctly stated by law

122. Laws of nature differ from man-made laws because

- (a) the former state facts of Nature
 (b) they must be obeyed
 (c) they are natural
 (d) unlike human laws, they are systematic

123. The laws of nature based on observation are

- (a) conclusion about the nature of the universe.
 (b) true and unfalsifiable.
 (c) figments of the observer imagination.
 (d) subject to change in the light of new facts.

124. **Direction: This question presents a sentence, part of which or all of which is underlined. Beneath the sentence you will find four ways of phrasing the underlined part. The first of these repeats the original; the other three are different. If you think the original is best, choose the first answer; otherwise choose one of the others.**

The administration discussed whether the number of students studying European languages was likely to decline when the senior lecturer retired.

- (a) whether the number of students studying European languages was likely
 (b) whether the number of students studying European languages were likely
 (c) if the students studying European languages were likely
 (d) if the number of European language students were likely

125. Choose the best pronunciation of the word, Restaurant, from the following options.

- (a) res-trawnt (b) res-tuh-rawnt
 (c) rest-rant (d) resto-raunt

SOLUTIONS

PART - I (PHYSICS)

1. (d) When work is done upon a system by a conservative force then its potential energy increases.
2. (a) de-Broglie wavelength is given by

$$\lambda = \frac{h}{p}, \text{ where } h = \text{Planck's constant and}$$

$p = \text{momentum}$

Also, energy (E) and momentum are related as

$$E = \frac{p^2}{2m}$$

$$\therefore p = \sqrt{2mE}$$

$$\therefore \lambda = \frac{h}{\sqrt{2mE}} \times \frac{1}{\sqrt{E}} \text{ as } h \text{ and } m \text{ are constants}$$

$$\text{Hence, } \frac{\lambda_o}{\lambda'} = \sqrt{\frac{E'}{E}} = \sqrt{\frac{2E}{E}} = \sqrt{2}$$

$$\therefore \lambda' = \frac{\lambda_o}{\sqrt{2}}$$

3. (a) For no current through the galvanometer, the wheatstone bridge should be balanced. For this, we must have

$$\frac{P}{Q} = \frac{S}{R}$$

This condition is satisfied with only option (a).

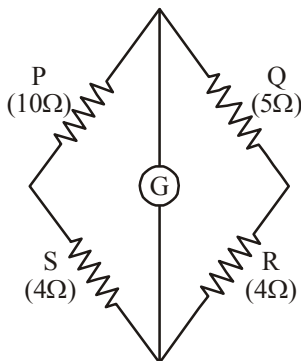

When a 5Ω resistor is connected in series

with Q, the equivalent resistance in the P-arm becomes 10Ω .

$$\therefore \frac{P}{Q} = \frac{10}{10} = 1$$

$$\text{and } \frac{S}{R} = \frac{4}{4} = 1$$

$$\Rightarrow \frac{P}{Q} = \frac{S}{R}$$

4. (a) When a dielectric slab of dielectric constant

$$K = \frac{3}{2} \text{ is inserted between the plates of } C_2,$$

its new capacitance (C'_2) becomes

$$C'_2 = \frac{3}{2}C$$

Equivalent capacitance of C'_2 and C_3 is

$$C_{eq} = C'_2 + C_3 = \frac{3}{2}C + C = \frac{5C}{2}$$

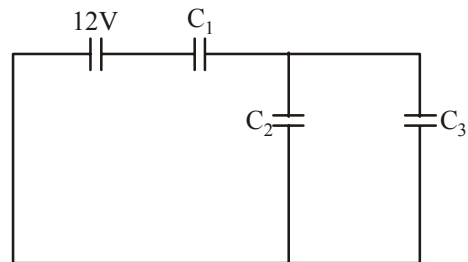

Now, C_{eq} and C_1 are in series. Therefore, their equivalent capacitance is

$$C_{eq} = \frac{C_{eq} \times C_1}{C_{eq} + C_1} = \frac{\frac{5C}{2} \times C}{\frac{5C}{2} + C}$$

$$= \frac{5C^2}{7C} = \frac{5C}{7}$$

5. (c) Terminal velocity,

$$v_T = \frac{2r^2(d_1 - d_2)g}{9\eta}$$

$$\frac{v_{T_2}}{0.2} = \frac{(10.5 - 1.5)}{(19.5 - 1.5)} \Rightarrow v_{T_2} = 0.2 \times \frac{9}{18}$$

$$\therefore v_{T_2} = 0.1 \text{ m/s}$$

6. (b) Magnetic field at the centre of the circular loop increases as it moves towards the current carrying wire as we know it varies inversely with the distance. Therefore, induced current in the loop should be such that it can reduce the increased magnetic field. This is possible only when the induced current is clockwise.

7. (b) $|e| = L \frac{dI}{dt}$
 Here, $e = 20 \text{ mV} = 20 \times 10^{-3} \text{ V}$
 $\frac{dI}{dt} = \frac{6 - 2}{2} = 2 \text{ A/s}$
 $L = ?$
 $\Rightarrow 20 \times 10^{-3} = L \times 2$

$$\therefore L = 10 \times 10^{-3} \text{ H} = 10 \text{ mH.}$$

8. (a) For the time $t < t_1$, area of loop changes. Hence, magnetic flux linked with it changes during this time and emf is induced thereby.
 9. (c) Hologram is based on the phenomenon of interference.
 10. (a) An equivalent of the given network is as shown in the figure.
 If R_p be the net resistance, then

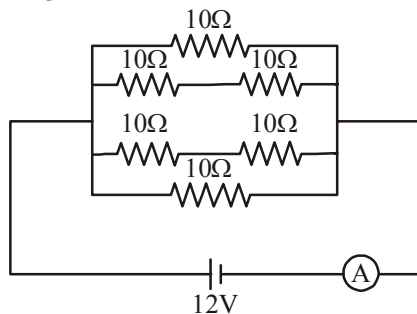

$$\frac{1}{R_p} = \frac{1}{10} + \left(\frac{1}{10+10} \right) + \left(\frac{1}{10+10} \right) + \frac{1}{10}$$

$$= \frac{1}{10} + \frac{1}{20} + \frac{1}{20} + \frac{1}{10}$$

$$= \frac{6}{20} = \frac{3}{10}$$

$$\therefore R_p = \frac{10}{3} \Omega$$

Hence, current flowing through ammeter is

$$I = \frac{V}{R_p} = \frac{12}{\left(\frac{10}{3}\right)} = 3.6 \text{ A.}$$

11. (c) Energy released in transition from state n_1 to n_2 is equal to the energy absorbed in transition from state n_2 to n_1 .
 12. (b) Magnetic field \propto no. of turns per unit length
 \therefore Required ratio = 1 : n.
 13. (d) R_1, R_2 and R_3 are in series. Therefore, same current will flow through all the resistors.
 14. (a) As the charged particle is at rest, no force will act on it due to the magnetic field produced by the conductor at the site of the charge. Hence, it will remain at rest.
 15. (b) $\frac{\Delta \ell}{\ell} = \alpha \Delta T = 10^{-5} \times 100 = 10^{-3}$
 $\frac{\Delta \ell}{\ell} \times 100\% = 10^{-3} \times 100$
 $= 10^{-1} = 0.1\%$

16. (d) When wavelength decreases, frequency increases. Also, we know that cut-off voltage (or stopping potential) increases when frequency increases. Hence, option (d) is correct. Note that work function and threshold frequency are constant for a given metal.

17. (b) Clearly,
 $Y = (A + B) \cdot C = (A \cdot C) + (B \cdot C)$
 For
 $A = 0, B = 0 \ \& \ C = 1, \ Y = (0.1) + (0.1) = 0$
 $A = 1, B = 0 \ \& \ C = 1, \ Y = (1.1) + (0.1) = 1$
 $A = 1, B = 0 \ \& \ C = 0, \ Y = (0.1) + (0.0) = 0$
 $A = 0, B = 1 \ \& \ C = 0, \ Y = (0.0) + (1.0) = 0$
 So, option (b) is correct.

18. (b) We have
 $h\nu = W_0 + E$, where E is the energy of emitted photoelectron

$$\Rightarrow \frac{hc}{\lambda} = W_0 + E$$

As hc and W_0 are constant,

$$E \propto \frac{1}{\lambda}$$

Therefore, as λ is doubled, E will become half.

$$19. (a) E = \frac{1}{4\pi\epsilon_0} \frac{qr}{R^3} = \frac{q}{\frac{4}{3}\pi R^3} \times \frac{r}{3\epsilon_0} = \frac{\rho \times r}{3\epsilon_0}$$

20. (b) The given point is on axis of $\frac{\vec{p}}{2}$ dipole and at equatorial line of \vec{p} dipole so that field at given point is $(\vec{E}_1 + \vec{E}_2)$

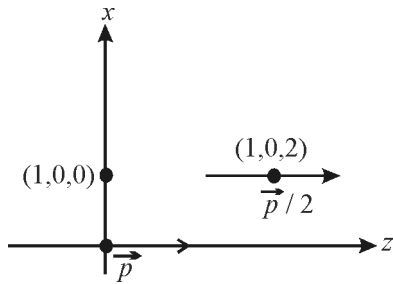

$$\vec{E}_1 = \frac{2K(p/2)}{2^3} = \frac{Kp}{8} (+\hat{k})$$

$$\vec{E}_2 = \frac{Kp}{1} (-\hat{k})$$

$$\vec{E}_1 + \vec{E}_2 = -\frac{7}{8}Kp(-\hat{k}) = -\frac{7p}{32\pi\epsilon_0} \hat{k}$$

$$21. (c) Y = \frac{F/A}{\Delta\ell/\ell} = \frac{250 \times 9.8}{50 \times 10^{-6}} \times \frac{2}{0.5 \times 10^{-3}} \Rightarrow 19.6 \times 10^{10} \text{ N/m}^2$$

$$22. (d) R_1 = R_0(1 + \alpha_1 t) + R_0(1 + \alpha_2 t)$$

$$= 2R_0 \left(1 + \frac{\alpha_1 + \alpha_2}{2} t \right)$$

Comparing with $R = R_0(1 + \alpha t)$

$$\alpha = \frac{\alpha_1 + \alpha_2}{2}$$

23. (a) Given; $J = ar^2$

$$i = \int_1^2 J \times 2\pi r dr = \int_{R/3}^{R/2} ar^2 \times 2\pi r dr$$

$$= 2\pi a \int_{R/3}^{R/2} r^3 dr = 2\pi a \left[\frac{r^4}{4} \right]_{R/3}^{R/2}$$

$$= \frac{\pi a}{2} \left[\left(\frac{R}{2} \right)^4 - \left(\frac{R}{3} \right)^4 \right]$$

$$= \frac{\pi a R^4}{2} \times \frac{65}{81 \times 16} = \frac{65 \pi a R^4}{2592}$$

24. (b) Decreasing R increases current in XY and there by increases the potential drop across XP and the balance point may be obtained. The current may be increased also by increasing V .

25. (b) Field due to one side of loop at O

$$= \frac{\mu_0 I}{4\pi \left(\frac{a}{2} \right)} (2 \sin 45^\circ)$$

Field at O due to all four sides is along unit vector \hat{e}_z

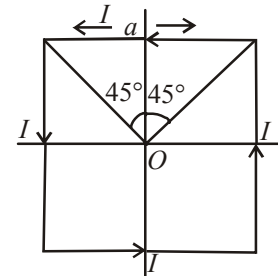

\therefore Total field

$$= 4 \cdot \frac{\mu_0 I}{4\pi \left(\frac{a}{2} \right)} (2 \sin 45^\circ) = \frac{2\sqrt{2}\mu_0 I}{\pi a}$$

26. (c) The angular momentum L of the particle is given by

$$L = mr^2\omega \text{ where } \omega = 2\pi n.$$

$$\therefore \text{Frequency } n = \frac{\omega}{2\pi};$$

$$\text{Further } i = q \times n = \frac{\omega q}{2\pi}$$

$$\text{Magnetic moment, } M = iA = \frac{\omega q}{2\pi} \times \pi r^2;$$

$$\therefore M = \frac{\omega q r^2}{2}$$

$$\text{So, } \frac{M}{L} = \frac{\omega q r^2}{2 m r^2 \omega} = \frac{q}{2m}$$

27. (c) Using Ampere's law, we have

$$\oint \vec{B} \cdot d\vec{\ell} = \mu_0 i_{in}$$

$$\text{or } B \times 2\pi r = \mu_0 \frac{i}{\pi R^2} \pi r^2$$

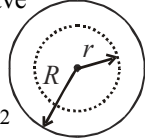

$$\therefore B = \frac{\mu_0}{2\pi} \cdot \frac{i r}{R^2}$$

28. (a) From Kirchoff's current law,

$$i_3 = i_1 + i_2 = 3 \sin \omega t + 4 \sin (\omega t + 90^\circ)$$

$$= \sqrt{3^2 + 4^2 + 2(3)(4) \cos 90^\circ} \sin (\omega t + \phi)$$

$$\text{where } \tan \phi = \frac{4 \sin 90^\circ}{3 + 4 \cos 90^\circ} = \frac{4}{3}$$

$$\therefore i_3 = 5 \sin (\omega t + 53^\circ)$$

29. (b) We know that, $Z = \frac{E_0}{I_0}$

$$\text{Given, } E_0 = 220 \text{ V and } I_0 = 10 \text{ A}$$

$$\text{so } Z = \frac{220}{10} = 22 \text{ ohm}$$

$$\phi = \left[\frac{\pi}{6} - \left(-\frac{\pi}{6} \right) \right] = \frac{\pi}{3}$$

$$\begin{aligned} P_a &= \frac{E_0}{\sqrt{2}} \times \frac{I_0}{\sqrt{2}} \times \cos \phi \\ &= \frac{220}{\sqrt{2}} \times \frac{10}{\sqrt{2}} \times \cos \frac{\pi}{3} = 550 \text{ W} \end{aligned}$$

30. (b) $I = I_0(1 - e^{-t/\tau})$

where $\tau \rightarrow$ time constant

$$\therefore \frac{3}{4} I_0 = I_0(1 - e^{-t/\tau})$$

$$\Rightarrow \frac{3}{4} = 1 - e^{-t/\tau} \Rightarrow e^{-t/\tau} = \frac{1}{4}$$

$$\Rightarrow \frac{-t}{\tau} \ln e = \ln \frac{1}{4} \Rightarrow \frac{-t}{\tau} = -2 \ln 2$$

$$\Rightarrow \tau = \frac{2}{\ln 2}$$

31. (a) $e = -\frac{d\phi}{dt} = [-2 + 8t + 0]$

$$\Rightarrow 8t = 2 \Rightarrow t = \frac{1}{4} \text{ sec} = 0.25 \text{ sec}$$

32. (d) $\sin i_c = \frac{1}{\mu} = \frac{r}{\sqrt{r^2 + h^2}}$

$$\text{Using } h = 12 \text{ cm, } \mu = 4/3$$

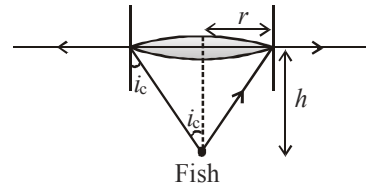

$$\text{We get } r = \frac{36}{\sqrt{7}} \text{ cm.}$$

33. (c) Apply conservation of momentum, $m_1 v_1 = (m_1 + m_2) v$

$$v = \frac{m_1 v_1}{(m_1 + m_2)}$$

$$\text{Here } v_1 = 36 \text{ km/hr} = 10 \text{ m/s,}$$

$$m_1 = 2 \text{ kg, } m_2 = 3 \text{ kg}$$

$$v = \frac{10 \times 2}{5} = 4 \text{ m/s}$$

$$\text{K.E. (initial)} = \frac{1}{2} \times 2 \times (10)^2 = 100 \text{ J}$$

$$\text{K.E. (Final)} = \frac{1}{2} \times (3 + 2) \times (4)^2 = 40 \text{ J}$$

$$\text{Loss in K.E.} = 100 - 40 = 60 \text{ J}$$

Alternatively use the formula

$$-\Delta E_k = \frac{1}{2} \frac{m_1 m_2}{(m_1 + m_2)} (u_1 - u_2)^2$$

34. (d) $P = 2 \left[\frac{100}{10} + \frac{100}{-20} + 0 \right]$

$$P = 10 \text{ dioptre.}$$

35. (a) $X_0 = \frac{\beta}{\lambda} (\mu - 1) t \Rightarrow 5\beta = \frac{\beta(0.45)t}{5890 \times 10^{-10}}$

$$\therefore t = \frac{5 \times 5890 \times 10^{-10}}{0.45} = 6.544 \times 10^{-4} \text{ cm}$$

36. (c) According to Malus' law₂
 $I = I_0 \cos^2 \theta = I_0 (\cos^2 60^\circ)$
 $= I_0 \times \left(\frac{1}{2}\right)^2 = \frac{I_0}{4}$

37. (b) $t_{1/2} = 3.8 \text{ day}$
 $\therefore \lambda = \frac{0.693}{t_{1/2}} = \frac{0.693}{3.8} = 0.182$

If the initial number of atom is $a = A_0$ then after time t the number of atoms is $a/20 = A$. We have to find t .

$$t = \frac{2.303}{\lambda} \log \frac{A_0}{A} = \frac{2.303}{0.182} \log \frac{a}{a/20}$$

$$= \frac{2.303}{0.182} \log 20 = 16.46 \text{ days}$$

38. (a) Nuclear radius, $r \propto A^{1/3}$
 where A is mass number

$$\frac{r_{\text{Cu}}}{r_{\text{Al}}} = \left(\frac{A_{\text{Cu}}}{A_{\text{Al}}}\right)^{1/3} = \left(\frac{64}{27}\right)^{1/3}$$

$$\Rightarrow r_{\text{Cu}} = 3.6 \left(\frac{4}{3}\right) = 4.8 \text{ Fermi}$$

39. (d) As $\frac{1}{\lambda} = R \left(\frac{1}{n_1^2} - \frac{1}{n_2^2} \right)$

$$\therefore \frac{1}{\lambda} = R \left(\frac{1}{1^2} - \frac{1}{n^2} \right)$$

Multiply both sides by λ

$$1 = \lambda R \left(1 - \frac{1}{n^2} \right) \quad \text{or} \quad \frac{1}{\lambda R} = 1 - \frac{1}{n^2}$$

$$\text{or} \quad \frac{1}{n^2} = 1 - \frac{1}{\lambda R} = \frac{\lambda R - 1}{\lambda R}$$

$$\text{or} \quad n = \sqrt{\frac{\lambda R}{\lambda R - 1}}$$

40. (a) $a = \mu g = \frac{6}{10}$ [using $v = u + at$]

$$\Rightarrow \mu = \frac{6}{10 \times g} = \frac{6}{10 \times 10} = 0.06$$

PART - II (CHEMISTRY)

41. (d) The common name of Pentanoic acid is valeric acid.

42. (d) Nitric acid not only nitrates, but also oxidizes the highly reactive ring as well, with loss of much material as dark-coloured tar. Furthermore, in the strongly acidic nitration medium, the amine is converted into anilinium ion ($-\text{NH}_3^+$); substitution is thus controlled not by the $-\text{NH}_2$ group but by the $-\text{NH}_3^+$ group which, because of its positive charge, directs the entering group to the *meta*- position instead of *ortho*, and *para*.

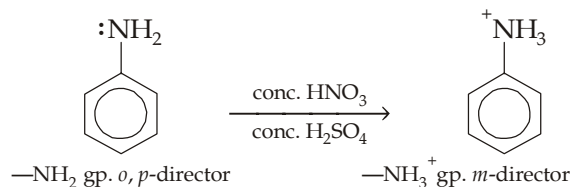

However, all these difficulties are overcome by protecting the amino group by acetylation, with either acetyl chloride or acetic anhydride. Acetylation ($-\text{NH}_2 \longrightarrow \text{NHCOCH}_3$) converts $-\text{NH}_2$ group to acetamido ($-\text{NHCOCH}_3$) group which is *o*, *p*-directing but lesser activating toward electrophilic aromatic substitution than the parent $-\text{NH}_2$ group.

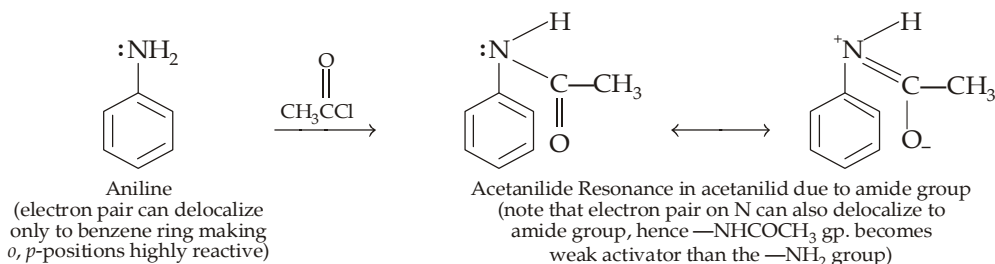

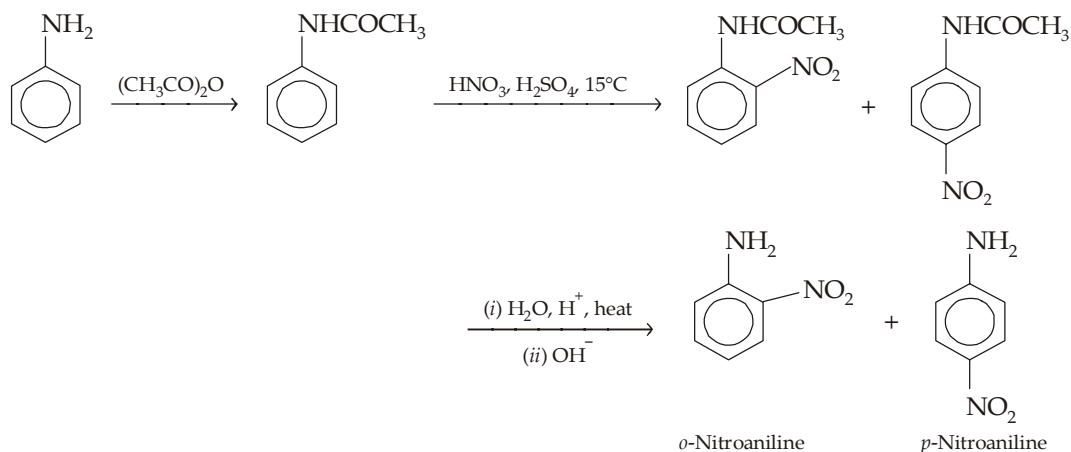

43. (c) The number of atoms of the ligands that are directly bound to the central metal atom or ion by coordinate bond is known as the coordination number of the metal atom or ion. Hence the coordination no. of the given compound will be 6.

44. (a) Complexes of the type $\text{M}_{\text{A}_3\text{B}_3}$ exist in two geometrical forms which are named as facial (fac-) and meridional (mer-isomers). $[\text{Co}(\text{NH}_3)_3(\text{NO}_2)_3]$ may be represented in fac- and mer-isomeric forms as follows.

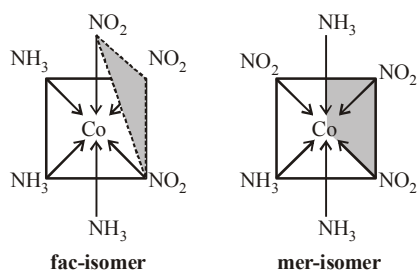

45. (c, d) Acetone on polymerisation give mesitylene

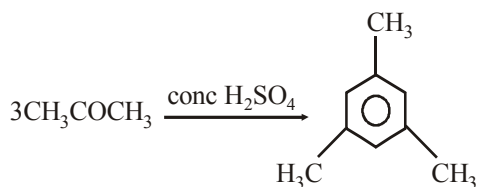

3 molecules of acetaldehyde produce paraldehyde $(\text{CH}_3\text{CHO})_3$ and 4 molecules of it produce metaldehyde $(\text{CH}_3\text{CHO})_4$.

46. (a)

47. (a) The most widely used method for preparing aromatic amines is the reduction of the nitro group to the amino group. This reduction can be achieved by catalytic hydrogenation, or most frequently with an acid and a metal (Fe, Zn, Sn) or a metal salt like SnCl_2 .

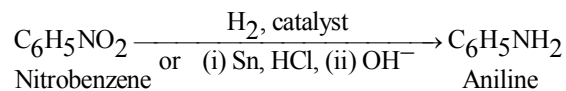

48. (a) The electronic configuration for Rb (37) is Rb(37)
 $= 1s^2 2s^2 2p^6 3s^2 3p^6 4s^2 3d^{10} 4p^6 5s^1$

$$\text{For } 5s^1, n = 5, \ell = 0, m = 0, s = \frac{1}{2}$$

49. (b) XeF_4 disproportionates in water giving solid XeO_3 on evaporation.

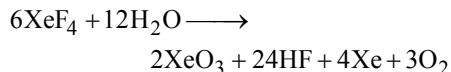

50. (b) Number of A ions in the unit cell

$$= \frac{1}{6} \times 8 = 1$$

Number of B ions in the unit cell

$$= \frac{1}{2} \times 6 = 3$$

Hence empirical formula of the compound = AB_3

51. (d) The electrical resistance of metals depends upon temperature. Electrical resistance decreases with decrease in temperature and becomes zero near the absolute temperature. Material in this state is said to possess super conductivity.

52. (a) An electron releasing group stabilises the carbocation by dispersing its positive charge and thus activates the ring while an electron-withdrawing group destabilises the carbocation by intensifying its positive charge and thus deactivates the ring.

$-\text{NH}_2$ being electron releasing group releases electron and thus tend to neutralise positive charge of the ring and itself becomes somewhat positive. The dispersal of positive charge of the ring stabilises carbocation and hence facilitates its formation which ultimately results an increased rate of reaction. Now since such factor is not present in benzene, its carbocation is less stable than (A). Hence aniline undergoes electrophilic substitution at a faster rate than benzene.

On the other hand in (C) the $-\text{NO}_2$ group (an electron withdrawing group) intensifies positive charge on the ring and thus destabilises the carbocation and hence its formation becomes difficult which ultimately results a slower reaction. Now since substituent is not present in benzene, its carbocation (B) is relatively more stable than (C). Hence nitrobenzene undergoes electrophilic substitution at a slower rate than benzene.

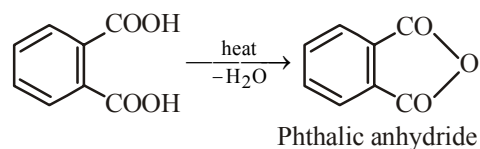
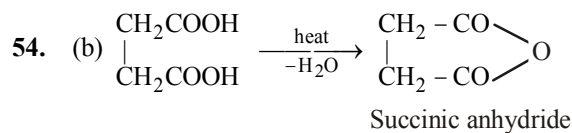
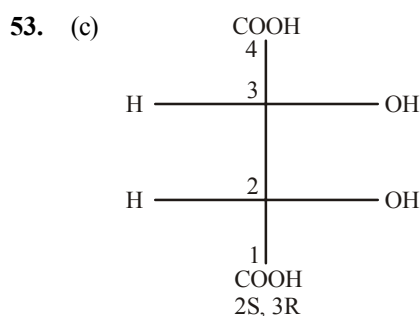

Oxalic on heating produces formic acid.

55. (a)

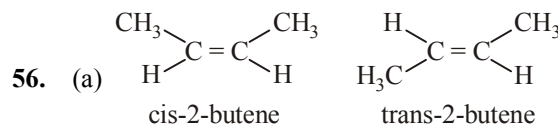
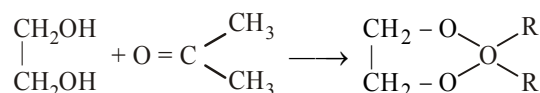

57. (c) Aldehydes and Ketones containing α -hydrogen undergo aldol condensation, since benzophenone does not have α -hydrogen hence do not undergo aldol condensation whereas acetophenone show this reaction due to presence of α -H atom.

58. (b) Isonitriles on reduction with LiAlH_4 give 2° amines



59. (c) Keratin

60. (c) For an isothermal process

$$\Delta S = 2.303 nR \log \frac{V_2}{V_1}$$

$$= 2.303 \times 1 \times 2 \log \frac{10}{1}$$

$$= 4.6 \text{ cal deg}^{-1} \text{ mol}^{-1}$$

61. (b) Energy of activation for forward reaction (E_a) = 85 kJ/mol

$$\therefore \text{Energy of activation for backward reaction} = E_a - \Delta H = 85 - 20 = 65 \text{ kJ mol}^{-1}$$

62. (a) Since the formation of ammonia is an exothermic reaction hence on increasing temperature, reaction will proceed in backward direction i.e. formation of NH_3 decreases.

63. (a) The atoms having half-filled and fully filled orbitals are comparatively more stable, hence more energy is required to remove

the electron from such atoms. Therefore group 15 have more I.E. than gp. 16 elements.

64. (c) Because of +I effect, t-butyl group destabilises the carbanion.

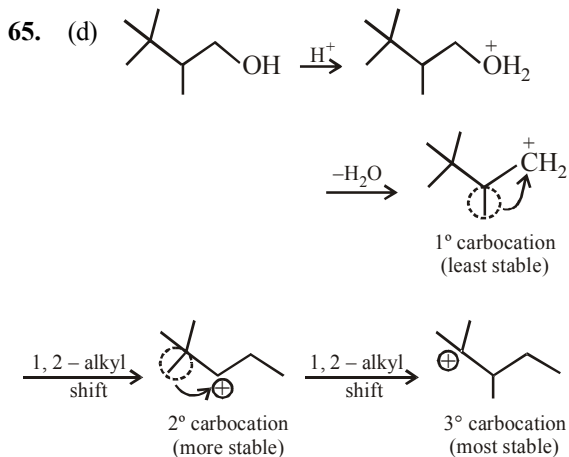

66. (c) We know $\Delta G^\circ = -nFE^\circ$

$$\therefore E^\circ = -\frac{\Delta G^\circ}{nF}$$

$$= +\frac{237.2 \times 1000 \text{ J}}{2 \times 96500} = 1.23 \text{ V} \quad [\because n=2]$$

67. (b) Solubility $S = \frac{1000k}{\lambda_{\text{AgCl}}^\circ} = \frac{1000 \times 2.6 \times 10^{-6}}{\lambda_{\text{Ag}^+}^\circ + \lambda_{\text{Cl}^-}^\circ}$

$$= \frac{2.6 \times 10^{-3}}{63 + 67} = 2 \times 10^{-5} \text{ mol L}^{-1}; K_{\text{sp}} = S^2$$

68. (c) For a reaction to be at equilibrium $\Delta G = 0$.
 Since $\Delta G = \Delta H - T\Delta S$ so at equilibrium $\Delta H - T\Delta S = 0$
 or $\Delta H = T\Delta S$
 For the reaction
 $\frac{1}{2}X_2 + \frac{3}{2}Y_2 \longrightarrow XY_3; \quad \Delta H = -30 \text{ kJ}$
 (given)
 Calculating ΔS for the above reaction, we get

$$\Delta S = 50 - \left[\frac{1}{2} \times 60 + \frac{3}{2} \times 40 \right] \text{ JK}^{-1}$$

$$= 50 - (30 + 60) \text{ JK}^{-1} = -40 \text{ JK}^{-1}$$

At equilibrium, $T\Delta S = \Delta H$

$$[\because \Delta G = 0]$$

$$\therefore T \times (-40) = -30 \times 1000 \quad [\because 1 \text{ kJ} = 1000 \text{ J}]$$

$$\text{or } T = \frac{-30 \times 1000}{-40} \text{ or } 750 \text{ K}$$

69. (b)

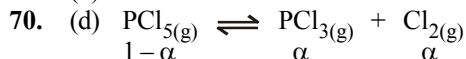

$$\alpha = \frac{x}{a} \quad (\text{degree of dissociation})$$

$$\text{Total moles} = 1 - \alpha + \alpha + \alpha = 1 + \alpha$$

$$K_p = \frac{P_{\text{PCl}_3} \times P_{\text{Cl}_2}}{P_{\text{PCl}_5}} = \frac{\left[\frac{\alpha}{1+\alpha} \cdot p \right] \left[\frac{\alpha}{1+\alpha} \cdot p \right]}{\frac{1-\alpha}{1+\alpha} \cdot p}$$

$$= \frac{\alpha^2 p}{1-\alpha^2} \Rightarrow \alpha = \left(\frac{K_p}{K_p + P} \right)^{1/2}$$

71. (b) $RT \ln K = -\Delta G^\circ = T\Delta S^\circ - \Delta H^\circ$;

$$\ln K = \frac{\Delta S^\circ}{R} - \frac{\Delta H^\circ}{RT}$$

Thus, a plot of $\ln K$ versus $1/T$ (abscissa) will be straight line with slope equal to

$$\frac{-\Delta H^\circ}{R} \text{ and intercept } \frac{\Delta S^\circ}{R}.$$

72. (c)

$$\frac{(t_{1/2})_1}{(t_{1/2})_2} = \left(\frac{a_2}{a_1} \right)^{n-1}; \quad \frac{120}{240} = \left(\frac{4 \times 10^{-2}}{8 \times 10^{-2}} \right)^{n-1}; n = 2$$

73. (c) From slow step:

$$\text{rate} = k_2[A][B] \quad \dots\dots\dots(\text{i})$$

From fast step:

$$K_e = \frac{[A]^2}{[A_2]} \text{ or } [A] = K_e^{1/2}[A_2]^{1/2} \quad \dots\dots\dots(\text{ii})$$

From (i) and (ii)

$$\text{rate} = k_2 k_e^{1/2} [A_2]^{1/2} [B] = k [A_2]^{1/2} [B]$$

74. (c) Using Arrhenius equation,

$$K = A e^{-\frac{E_a}{Rt}}, \text{ we get}$$

$$\log k = \log A - \frac{E_a}{2.303RT} \quad \therefore$$

$$\log k_1 = \log A - \frac{E_{a(1)}}{2.303RT} \quad \dots(i)$$

$$\text{and } \log k_2 = \log A - \frac{E_{a(2)}}{2.303RT} \quad \dots(ii)$$

$$\text{or } \log \frac{k_2}{k_1} = \frac{1}{2.303RT} [E_{a(1)} - E_{a(2)}]$$

(from (i) and (ii))

$$= \frac{1}{2.303 \times 8.314 \times 300} (76000 - 57000)$$

$$\text{or } \log \frac{k_2}{k_1} = \frac{19000}{2.303 \times 8.314 \times 300}$$

$$= \frac{190}{6.9 \times 8.314}$$

$$\text{or } \frac{k_2}{k_1} = 2000 \text{ [taking antilog]}$$

75. (a) $\bar{v} = RZ^2 \left(\frac{1}{2^2} - \frac{1}{3^2} \right)$

$$= R \left(\frac{1}{4} - \frac{1}{9} \right) = \frac{5R}{36}$$

76. (d) The products of the concerned reaction react each other forming back the reactants.

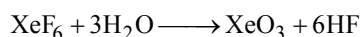

77. (c) Although in both cases products are CH_3I and $\text{C}_6\text{H}_5\text{OH}$; the two reactions follow different mechanism.

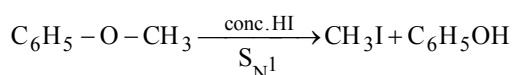
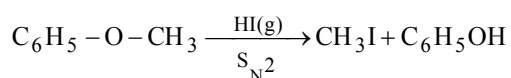

Remember that during $\text{S}_{\text{N}}1$ reaction, CH_3^+ is formed because it is more stable than C_6H_5^+ .

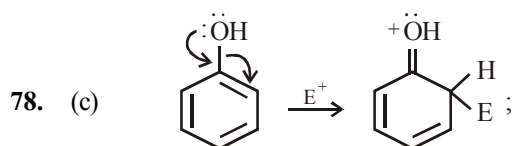

+ M effect in phenol activates benzene ring

Oxonium ion (more stable)

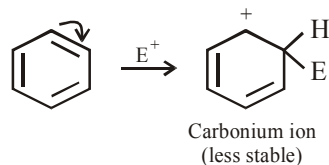

High stability of oxonium ion (oxocation) is because here every atom (except H) has a complete octet of electrons, while in carbocations, carbon bearing positive charge is having six electrons.

79. (c) Baeyer - Villiger oxidation involves the conversion of a cyclic ketone to a lactone, or an acyclic ketone into ester.

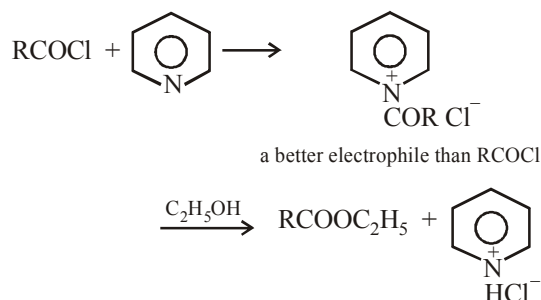
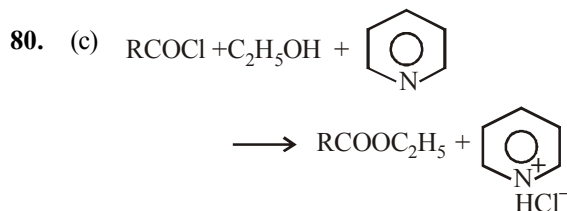

PART - III (MATHEMATICS)

81. (b) $1 + y^2 + (x - e^{\tan^{-1}y}) \frac{dy}{dx} = 0$

$$\Rightarrow (1 + y^2)dx = (e^{\tan^{-1}y} - x)dy$$

$$\Rightarrow \frac{dx}{dy} = \frac{e^{\tan^{-1}y} - x}{1 + y^2}$$

$$\Rightarrow \frac{dx}{dy} + \frac{1}{1 + y^2} \cdot x = \frac{e^{\tan^{-1}y}}{1 + y^2}$$

Which is the linear differential equation of the form $\frac{dx}{dy} + Rx = S$, where R and S are functions of y or constant (s)

$$\therefore \text{I.F} = \int \frac{1}{1+y^2} dy = e^{\tan^{-1} y}$$

Hence required solution is

$$x \cdot (\text{I.F.}) = \int \frac{e^{\tan^{-1} y}}{1+y^2} (\text{I.F.}) dy$$

$$\Rightarrow x \cdot e^{\tan^{-1} y} = \int \frac{e^{\tan^{-1} y}}{1+y^2} (e^{\tan^{-1} y}) dy$$

$$\Rightarrow x \cdot e^{\tan^{-1} y} = \int \frac{e^{2 \tan^{-1} y}}{1+y^2} dy \quad \dots(1)$$

Put $t = \tan^{-1} y$

$$\therefore \frac{dt}{dy} = \frac{1}{1+y^2} \Rightarrow dt = \frac{1}{1+y^2} dy$$

$$\therefore \int \frac{e^{2 \tan^{-1} y}}{1+y^2} dy = \int e^{2t} dt = \frac{e^{2t}}{2} + K$$

Hence equation (1) becomes,

$$x e^{\tan^{-1} y} = \frac{1}{2} e^{2t} + K$$

$$\Rightarrow x e^{\tan^{-1} y} = \frac{1}{2} e^{2 \tan^{-1} y} + K$$

$$\Rightarrow 2x e^{\tan^{-1} y} = e^{2 \tan^{-1} y} + K$$

82. (a) $\overline{AO} = \hat{i} + 2\hat{j} + \hat{k}$
 $\overline{AC} = -2\hat{i} - \hat{j} + \hat{k}$
 Angle between faces OAB and ABC
 = Angle between \overline{AO} and \overline{AC}
 If θ be the angle between \overline{AO} and \overline{AC} ,
 then

$$\cos \theta = \frac{\overline{AO} \cdot \overline{AC}}{|\overline{AO}| |\overline{AC}|}$$

$$= \frac{1 \times (-2) + 2 \times (-1) + 1 \times 1}{\sqrt{1+4+1} \sqrt{4+1+1}} = \frac{-3}{6}$$

$$= -\frac{1}{2} = \cos 120^\circ$$

$$\therefore \theta = 120^\circ$$

83. (c) Given ellipse: $\frac{x^2}{16} + \frac{y^2}{b^2} = 1$

$$\text{Now } b^2 = a^2 (1 - e^2)$$

$$\Rightarrow b^2 = 16 (1 - e^2), \Rightarrow \frac{b^2}{16} = 1 - e^2$$

$$\Rightarrow e^2 = 1 - \frac{b^2}{16} = \frac{16 - b^2}{16} \Rightarrow e = \frac{\sqrt{16 - b^2}}{4}$$

$$\text{Foci} = (\pm ae, 0) = \left(\pm \sqrt{16 - b^2}, 0 \right)$$

$$\text{Given hyperbola: } \frac{x^2}{144} - \frac{y^2}{81} = \frac{1}{25}$$

$$\Rightarrow \frac{x^2}{\left(\frac{12}{5}\right)^2} - \frac{y^2}{\left(\frac{9}{5}\right)^2} = 1$$

$$\text{Now, } b^2 = a^2 (e^2 - 1)$$

$$\Rightarrow \left(\frac{9}{5}\right)^2 = \left(\frac{12}{5}\right)^2 (e^2 - 1)$$

$$\Rightarrow \left(\frac{9}{12}\right)^2 = e^2 - 1,$$

$$\Rightarrow e^2 = 1 + \frac{81}{144} = \frac{144 + 81}{144}$$

$$\Rightarrow e = \frac{15}{12} = \frac{5}{4}$$

$$\text{Foci} = (\pm ae, 0) = (\pm 3, 0)$$

Since foci of the given ellipse and hyperbola coincide, therefore

$$\sqrt{16 - b^2} = 3 \Rightarrow 16 - b^2 = 9$$

$$\therefore b^2 = 7$$

84. (a) $f'(3) = \tan \frac{3\pi}{4} = -\tan \frac{\pi}{4} = -1$

85. (b) Required probability
 = P(First win) \times P(First win) \times P(Second win)
 + P(First Defeat) \times P(First win) \times P(Second win)

$$= \frac{1}{2} \times \frac{1}{2} \times \frac{1}{2} + \frac{1}{2} \times \frac{1}{2} \times \frac{1}{2} = \frac{1}{4}$$

86. (b) $\vec{a} + \vec{b} + \vec{c} = 0$
 $\Rightarrow (\vec{a} + \vec{b} + \vec{c})^2 = 0$
 $\Rightarrow |\vec{a}|^2 + |\vec{b}|^2 + |\vec{c}|^2 + 2(\vec{a}\vec{b} + \vec{b}\vec{c} + \vec{c}\vec{a}) = 0$
 $\Rightarrow 9 + 4 + 1 + 2(\vec{a}\vec{b} + \vec{b}\vec{c} + \vec{c}\vec{a}) = 0$
 $\Rightarrow \vec{a}\vec{b} + \vec{b}\vec{c} + \vec{c}\vec{a} = 7$

87. (d) Let $r(x) = f(x) \cdot g(x)$
 $= x^2 \cdot 2x = 2x^3$
 $r'(x) = 6x^2$
Put $6x^2 = 0$, $\therefore x = 0$
Max $r(x) = 2(2)^3 = 16$
or Max $(f(x), g(x)) = 16$

x	0	2
$r(x)$	0	16

$$I(x) = \int_0^2 16 dx$$

$$I(x) = [16x]_0^2 = 32 - 0 = 32$$

88. (b) $B = ABA^{-1}$ (Given)
But $B = BAA^{-A}$
 $\therefore ABA^{-1} = BAA^{-1} \Rightarrow AB = BA$
Now $(A + B)(A - B) = A^2 - AB + BA - B^2$
 $= A^2 - AB + AB - B^2$ [$\because AB = BA$]
 $= A^2 - B^2$

89. (b) $(1 + \omega - \omega^2)^7 = (-\omega^2 - \omega^2)^7 = (-2\omega^2)^7$
 $= -128(\omega^4)^3 \omega^2 = -128\omega^2$

90. (d) Here, $r = (2\hat{i} + 3\hat{j} + \hat{k}) - (i + 2\hat{j} + 3\hat{k})$
 $\Rightarrow r = i + \hat{j} - 2\hat{k}$ and $F = i + \hat{j} + \hat{k}$
Then, the required moment is given by
 $r \times F = (i + \hat{j} - 2\hat{k}) \times (i + \hat{j} + \hat{k})$

$$= \begin{vmatrix} \hat{i} & \hat{j} & \hat{k} \\ 1 & 1 & -2 \\ 1 & 1 & 1 \end{vmatrix} = 3\hat{i} - 3\hat{j}$$

\therefore Moment about given point $= 3\hat{i} - 3\hat{j}$

91. (b) $g(x) \cdot g(y) = g(x) + g(y) + g(xy) - 2$... (1)
Put $x = 1, y = 2$, then
 $g(1) \cdot g(2) = g(1) + g(2) + g(2) - 2$
 $5g(1) = g(1) + 5 + 5 - 2$
 $4g(1) = 8 \quad \therefore g(1) = 2$

Put $y = \frac{1}{x}$ in equation (1), we get

$$g(x) \cdot g\left(\frac{1}{x}\right) = g(x) + g\left(\frac{1}{x}\right) + g(1) - 2$$

$$g(x) \cdot g\left(\frac{1}{x}\right) = g(x) + g\left(\frac{1}{x}\right) + 2 - 2$$

$$[\because g(1) = 2]$$

This is valid only for the polynomial

$$\therefore g(x) = 1 \pm x^n \quad \dots (2)$$

Now $g(2) = 5$ (Given)

$$\therefore 1 \pm 2^n = 5 \quad [\text{Using equation (2)}]$$

$$\pm 2^n = 4, \Rightarrow 2^n = 4, -4$$

Since the value of 2^n cannot be -Ve.

$$\text{So, } 2^n = 4, \Rightarrow n = 2$$

Now, put $n = 2$ in equation (2), we get

$$g(x) = 1 \pm x^2$$

$$\therefore \lim_{x \rightarrow 3} g(x) = \lim_{x \rightarrow 3} (1 \pm x^2) = 1 \pm (3)^2$$

$$= 1 \pm 9 = 10, -8$$

92. (c) Any tangent to parabola $y^2 = 8x$ is $y =$

$$mx + \frac{2}{m} \quad \dots (i)$$

It touches the circle $x^2 + y^2 - 12x + 4 = 0$, if the length of perpendicular from the centre (6, 0) is equal to radius $\sqrt{32}$.

$$\therefore \frac{6m + \frac{2}{m}}{\sqrt{m^2 + 1}} = \pm \sqrt{32}$$

$$\Rightarrow \left(3m + \frac{1}{m}\right)^2 = 8(m^2 + 1)$$

$$\Rightarrow (3m^2 + 1)^2 = 8(m^4 + m^2)$$

$$\Rightarrow m^4 - 2m^2 + 1 = 0 \Rightarrow m = \pm 1$$

Hence, the required tangents are $y = x + 2$ and $y = -x - 2$.

93. (b) Given $e^x = y + \sqrt{1 + y^2}$

$$\Rightarrow e^x - y = \sqrt{1 + y^2}$$

Squaring both side, we have

$$e^{2x} + y^2 - 2e^x y = 1 + y^2$$

$$\Rightarrow 2e^x y = e^{2x} - 1$$

$$\Rightarrow y = \frac{e^{2x} - 1}{2e^x} \Rightarrow y = \frac{1}{2} [e^x - e^{-x}]$$

94. (d) If curve $r = a \sin 3\theta$
To trace the curve, we consider the following table :

$3\theta =$	0	$\frac{\pi}{2}$	π	$\frac{3\pi}{2}$	2π	$\frac{5\pi}{2}$	3π
$\theta =$	0	$\frac{\pi}{6}$	$\frac{\pi}{3}$	$\frac{\pi}{2}$	$\frac{2\pi}{3}$	$\frac{5\pi}{6}$	π
$r =$	0	a	0	-a	0	a	0

Thus there is a loop between $\theta = 0$ & $\theta = \frac{\pi}{3}$

as r varies from $r = 0$ to $r = 0$.

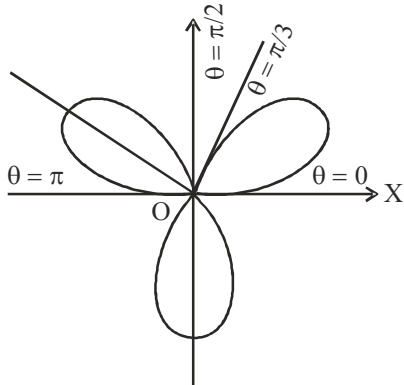

Hence, the area of the loop lying in the

$$\text{positive quadrant} = \frac{1}{2} \int_0^{\frac{\pi}{3}} r^2 d\theta$$

$$= \frac{1}{2} \int_0^{\frac{\pi}{3}} \sin^2 \phi \cdot \frac{1}{3} d\phi$$

[On putting, $3\theta = \phi \Rightarrow d\theta = \frac{1}{3} d\phi$]

$$= \frac{a^2}{6} \int_0^{\frac{\pi}{2}} \sin^2 \phi d\phi$$

$$= \frac{a^2}{6} \cdot \int_0^{\frac{\pi}{2}} \frac{1 - \cos 2\phi}{2} d\phi \left[\because \cos 2\theta = 1 - 2\sin^2 \theta \right]$$

$$= \frac{a^2}{12} \cdot \left[\phi + \frac{\sin 2\phi}{2} \right]_0^{\frac{\pi}{2}}$$

$$= \frac{a^2}{12} \cdot \left[\frac{\pi}{2} + \sin \pi \right] = \frac{a^2 \pi}{24}$$

95. (a) Replacing each hexadecimal digit by the corresponding 4-digit binary numeral, we have
 $(ABCD)_{16} = (1010 1011 1100 1101)_2$

96. (c) Let the normal at ' t_1 ' cuts the parabola again at the point ' t_2 '. the equation of the normal at $(at_1^2, 2at_1)$ is $y + t_1x = 2at_1 + at_1^3$
Since it passes through the point ' t_2 ' i.e $(at_2^2, 2at_2)$

$$\therefore 2at_2 + at_1t_2^2 = 2at_1 + at_1^3$$

$$\Rightarrow 2a(t_1 - t_2) + at_1(t_1^2 - t_2^2) = 0$$

$$\Rightarrow 2 + t_1(t_1 + t_2) = 0 \quad (\because t_1 - t_2 \neq 0)$$

$$\Rightarrow 2 + t_1^2 + t_1t_2 = 0$$

$$\Rightarrow t_1t_2 = -(t_1^2 + 2) \Rightarrow t_2 = -\left(t_1 + \frac{2}{t_1}\right)$$

97. (b) $s = t^3 - 12t^2 + 6t + 8$

$$\frac{ds}{dt} = 3t^2 - 24t + 6$$

$$\frac{d^2s}{dt^2} = 6t - 24$$

$$\text{Acceleration} = 0$$

$$\Rightarrow 6t - 24 = 0$$

$$\therefore t = 4$$

$$\text{Required velocity} = \left. \frac{ds}{dt} \right|_{t=4}$$

$$= 3 \times (4)^2 - 24 \times 4 + 6$$

$$= 48 - 96 + 6 = 42 \text{ units}$$

98. (a) $X = a \cdot b$

99. (b) Let $\cos^{-1} \frac{1}{8} = \theta$, where $0 < \theta < \frac{\pi}{2}$.

$$\Rightarrow \frac{1}{2} \cos^{-1} \frac{1}{8} = \frac{1}{2} \theta$$

$$\Rightarrow \cos\left(\frac{1}{2} \cos^{-1} \frac{1}{8}\right) = \cos \frac{1}{2} \theta$$

$$\text{Now, } \cos^{-1} \frac{1}{8} = \theta \Rightarrow \cos \theta = \frac{1}{8}$$

$$\Rightarrow 2 \cos^2 \frac{\theta}{2} - 1 = \frac{1}{8}$$

$$\Rightarrow \cos^2 \frac{\theta}{2} = \frac{9}{16} \Rightarrow \cos \frac{\theta}{2} = \frac{3}{4}$$

$$[\because 0 < \frac{\theta}{2} < \frac{\pi}{4}, \text{ so } \cos \frac{\theta}{2} \neq -\frac{3}{4}]$$

100. (c) Two constraints are $x \geq 0, y \geq 0$ and the third one will be of the type $ax + by \leq c$.

101. (b) Let y denote the number of bacteria at any instant t . then according to the question

$$\frac{dy}{dt} \propto y \Rightarrow \frac{dy}{y} = k dt \quad \dots (i)$$

k is the constant of proportionality, taken to be +ve on integrating (i), we get

$$\log y = kt + c \quad \dots (ii)$$

c is a parameter. let y_0 be the initial number of bacteria

i.e., at $t=0$ using this in (ii), $c = \log y_0$

$$\Rightarrow \log y = kt + \log y_0$$

$$\Rightarrow \log \frac{y}{y_0} = kt \quad \dots (iii)$$

$$y = \left(y_0 + \frac{10}{100} y_0 \right) = \frac{11y_0}{10}, \text{ when } t = 2$$

$$\text{So, from (iii), we get } \log \frac{11y_0}{y_0} = k(2)$$

$$\Rightarrow k = \frac{1}{2} \log \frac{11}{10} \quad \dots (iv)$$

$$\text{Using (iv) in (iii) } \log \frac{y}{y_0} = \frac{1}{2} \left(\log \frac{11}{10} \right) t \quad \dots (v)$$

let the number of bacteria become 1, 00, 000 to 2,00,000 in t_1 hours. i.e., $y = 2y_0$ when $t = t_1$ hours. from (v)

$$\log \frac{2y_0}{y_0} = \frac{1}{2} \left(\log \frac{11}{10} \right) t_1 \Rightarrow t_1 = \frac{2 \log 2}{\log \frac{11}{10}}$$

$$\text{Hence, the reqd. no. of hours} = \frac{2 \log 2}{\log \frac{11}{10}}$$

102. (b) Consider $\sin^{-1} \left(\frac{1}{\sqrt{5}} \right) + \cot^{-1} 3 \quad \dots (i)$

$$\text{We have, } \sin^{-1} \left(\frac{1}{\sqrt{5}} \right) = \cot^{-1} 2$$

\therefore From equation (i), we have

$$\cos^{-1} 2 + \cot^{-1} 3 = \tan^{-1} \frac{1}{2} + \tan^{-1} \frac{1}{3}$$

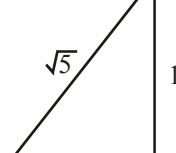
$$= \tan^{-1} \left(\frac{\frac{1}{2} + \frac{1}{3}}{1 - \frac{1}{2} \cdot \frac{1}{3}} \right)$$

$$= \tan^{-1} \left(\frac{5/6}{6-1} \right) = \tan^{-1} 1 = \frac{\pi}{4}$$

103. (b) We have,
 $abcd = \cos(2\alpha + 2\beta + 2\gamma + 2\delta) + i \sin(2\alpha + 2\beta + 2\gamma + 2\delta)$

$$\therefore \sqrt{abcd} = [\cos(2\alpha + 2\beta + 2\gamma + 2\delta) + i \sin(2\alpha + 2\beta + 2\gamma + 2\delta)]^{1/2}$$

$$\text{or } \sqrt{abcd} = \cos(\alpha + \beta + \gamma + \delta) + i \sin(\alpha + \beta + \gamma + \delta) \dots (1)$$

[De Moivre's Theorem]

$$\therefore \frac{1}{\sqrt{abcd}} = \cos(\alpha + \beta + \gamma + \delta) - i \sin(\alpha + \beta + \gamma + \delta) \quad \dots (2)$$

Adding (1) and (2), we obtain

$$\sqrt{abcd} + \frac{1}{\sqrt{abcd}} = 2 \cos(\alpha + \beta + \gamma + \delta)$$

104. (a) Standard deviation $\sigma = \sqrt{npq} \geq 0$

Now mean = $np = 25$ and $q < 1$

$$\text{So } \sigma = \sqrt{npq} < \sqrt{np} = 5$$

$$\therefore 0 \leq \sigma < 5$$

105. (d) Number of ways

$$= [({}^3C_3 + {}^4C_3 + {}^5C_3 + {}^6C_3 + {}^7C_3) \times 2 + {}^8C_3] \times 2 = 392$$

106. (d) $\therefore \text{rank}(AB) \leq \text{rank}(A)$

and $\text{rank}(AB) \leq \text{rank}(B)$

Therefore $\text{rank}(AB) \leq \min(\text{rank } A, \text{rank } B)$

107. (a) Let $A \equiv (a, 0, 0), B \equiv (0, b, 0), C \equiv (0, 0, c)$, then

$$\text{equation of the plane is } \frac{x}{a} + \frac{y}{b} + \frac{z}{c} = 1$$

Its distance from the origin,

$$\frac{1}{a^2} + \frac{1}{b^2} + \frac{1}{c^2} = \frac{1}{p^2} \quad \dots (i)$$

If (x, y, z) be centroid of ΔABC , then

$$x = \frac{a}{3}, y = \frac{b}{3}, z = \frac{c}{3} \quad \dots (ii)$$

Eliminating a, b, c from (i) and (ii) required locus is

$$x^{-2} + y^{-2} + z^{-2} = 9p^{-2}$$

- 108. (c)** There are 26 red cards and 26 black cards
i.e., total number of cards = 52
P(both cards of different colours)
= P(B)P(R) + P(R)P(B)

$$= \frac{26}{52} \times \frac{26}{51} + \frac{26}{52} \times \frac{26}{51} = 2 \left(\frac{26}{52} \times \frac{26}{51} \right) = \frac{26}{51}$$

- 109. (a)** The equation of the hyperbola is

$$x^2 - 2y^2 - 2x + 8y - 1 = 0$$

$$\text{or } (x-1)^2 - 2(y-2)^2 + 6 = 0$$

$$\text{or } \frac{(x-1)^2}{-6} + \frac{(y-2)^2}{3} = 1$$

$$\text{or } \frac{(y-2)^2}{3} - \frac{(x-1)^2}{6} = 1 \quad \dots(1)$$

$$\text{or } \frac{Y^2}{3} - \frac{X^2}{6} = 1$$

$$\text{where } X = x - 1 \text{ and } Y = y - 2 \quad \dots(2)$$

\therefore The centre = (0, 0) in the X-Y co-ordinates.

\therefore The centre = (1, 2) in the x-y co-ordinates, using (2).

If the transverse axis be of length 2a, then a

= $\sqrt{3}$, since in the equation (1) the transverse axis is parallel to the y-axis.

If the conjugate axis is of length 2b, then

$$b = \sqrt{6}.$$

$$\text{But } b^2 = a^2(e^2 - 1)$$

$$\therefore 6 = 3(e^2 - 1), \therefore e^2 = 3 \text{ or } e = \sqrt{3}.$$

$$\text{The length of the transverse axis} = 2\sqrt{3}.$$

$$\text{The length of the conjugate axis} = 2\sqrt{6}.$$

$$\text{Latus rectum} = \frac{2b^2}{a} = \frac{2 \times 6}{\sqrt{3}} = 4\sqrt{3}$$

- 110. (c)** Probability of getting a blue ball at any draw

$$= p = \frac{10}{20} = \frac{1}{2}$$

P [getting a blue ball 4th time in 7th draw]
= P [getting 3 blue balls in 6 draw] \times P [a blue ball in the 7th draw].

$$= {}^6C_3 \left(\frac{1}{2} \right)^3 \left(\frac{1}{2} \right)^3 \cdot \frac{1}{2}$$

$$= \frac{6 \times 5 \times 4}{1 \times 2 \times 3} \left(\frac{1}{2} \right)^7 = 20 \times \frac{1}{32 \times 4} = \frac{5}{32}$$

- 111. (d)** For the first circle centre = (3, 7)

$$\text{Radius } r_1 = \sqrt{3^2 + 7^2 - 48} = \sqrt{10}$$

For the second circle, centre (3, 0); radius $r_2 = 3$

So, $r_1 + r_2 < d$ (distance between the centres)

\therefore Circle don't cut and hence the number of common tangents = 4.

- 112. (d)** We have,
 $\cos^2\theta + \sin\theta + 1 = 0 \Rightarrow 1 - \sin^2\theta + \sin\theta + 1 = 0$

$$\Rightarrow \sin\theta = -1 \quad (\because \sin\theta \neq 2) \Rightarrow \theta = 3\pi/2$$

$$\therefore \theta \in \left(\frac{5\pi}{4}, \frac{7\pi}{4} \right)$$

- 113. (c)** $\lim_{x \rightarrow 0} f(x) = \lim_{x \rightarrow 0} [(1+x)^{1/x}]^2 = e^2 = f(0)$

- 114. (d)** $\log y = \frac{x}{\log x} \log 2$

$$\Rightarrow \left. \frac{dy}{dx} \right|_{x=e} = 0$$

- 115. (d)** $\int \frac{dx}{x^2(x^4+1)^{3/4}} = \int \frac{dx}{x^5 \left(1 + \frac{1}{x^4} \right)^{3/4}}$

$$\text{Put } 1 + \frac{1}{x^4} = t \Rightarrow -\frac{4}{x^5} dx = dt$$

So, integral is

$$I = -\frac{1}{4} \int \frac{dt}{t^{3/4}} = -t^{1/4} + c = -\left(1 + \frac{1}{x^4} \right)^{1/4} + c$$

- 116. (a)** The number of words starting from A are $5! = 120$

The number of words starting from I are $5! = 120$

The number of words starting from KA are $4! = 24$

The number of words starting from KI are $4! = 24$

The number of words starting from KN are $4! = 24$

The number of words starting from KRA are $3! = 6$

The number of words starting from KRIA are $2! = 2$

The number of words starting from KRIN are $2! = 2$

The number of words starting from KRISA are $1! = 1$

The number of words starting from KRISNA are $1! = 1$

Hence, rank of word 'KRISNA' $= 2(120) + 3(24) + 6 + 2(2) + 2(1) = 324$

117. (b) The lines are $\frac{x}{6} = \frac{y+2}{6} = \frac{z-1}{1}$

and $\frac{x+1}{12} = \frac{y}{6} = \frac{z}{-1}$

Here,

$$\vec{a}_1 = -2\hat{j} + \hat{k}, \vec{b}_1 + 6\hat{i} + 6\hat{j} + \hat{k}, \vec{a}_2 = -\hat{i},$$

$$\vec{b}_2 = 12\hat{i} + 6\hat{j} - \hat{k}$$

$$\vec{b}_1 \times \vec{b}_2 = \begin{vmatrix} \hat{i} & \hat{j} & \hat{k} \\ 6 & 6 & 1 \\ 12 & 6 & -1 \end{vmatrix} = -12\hat{i} + 18\hat{j} - 36\hat{k}$$

$$\text{Shortest distance} = \frac{|(\vec{a}_2 - \vec{a}_1) \cdot (\vec{b}_1 - \vec{b}_2)|}{|\vec{b}_1 \times \vec{b}_2|}$$

$$= \frac{|(-\hat{i} + 2\hat{j} - \hat{k}) \cdot (-12\hat{i} + 18\hat{j} - 36\hat{k})|}{\sqrt{(-12)^2 + (18)^2 + (-36)^2}}$$

$$= \frac{|+12 + 36 + 36|}{\sqrt{1764}} = \frac{84}{42} = 2$$

118. (b) Given $f(x) = 2 - |x - 5|$
Domain of $f(x)$ is defined for all real values of x .

Since, $|x - 5| \geq 0 \Rightarrow -|x - 5| \leq 0$

$\Rightarrow 2 - |x - 5| \leq 2 \Rightarrow f(x) \leq 2$

Hence, range of $f(x)$ is $(-\infty, 2]$.

119. (a) If A and B are two sets having m and n elements such that

$$1 \leq n \leq m = \sum_{r=1}^n (-1)^{n-r} {}^n C_r r^m$$

Number of surjection from A to B

$$= \sum_{r=1}^n (-1)^{2-r} {}^2 C_r r^4$$

$$= (-1)^{2-1} {}^2 C_1 (1)^4 + (-1)^{2-2} {}^2 C_2 (2)^4 = -2 + 16 = 14$$

120. (d) Let $I = \int_a^b x f(x) dx$

Let $a + b - x = z \Rightarrow -dx = dz$

When $x = a, z = b$ and when $x = b, z = a$

$$\therefore I = -\int_b^a (a + b - z) f(z) dz$$

$$I = (a + b) \int_b^a f(x) dx - \int_a^b x f(x) dx$$

$$I = (a + b) \int_b^a f(x) dx - I;$$

$$2I = (a + b) \int_b^a f(x) dx$$

$$\text{Hence, } I = \left(\frac{a+b}{2}\right) \int_a^b f(x) dx$$

PART - IV (ENGLISH)

121 (b)

122 (a)

123 (d)

124 (a) "Whether" is correct because the question concerns a choice not a condition. With the expression "the number of" a singular verb is needed and hence "was" is correct. "Liable" is used in expressions such as "liable to prosecution" and not for expressions of possibility.

125 (b)