



collegebatch.com

click to campus

VITEEE 2007 Question Paper

Vellore Institute of Technology Engineering Entrance Examination

Download more VITEEE Previous Year Question Papers: [Click Here](#)

SOLVED PAPER

VITEEE
2007

PART - I (PHYSICS)

- The magnetic moment of the ground state of an atom whose open sub shell is half filled with five electrons is
 - $\sqrt{35} \sqrt{\mu_B}$
 - $35 \mu_B$
 - $35\sqrt{\mu_B}$
 - $\mu_B \sqrt{35}$
- Indicate which one of the following statements is NOT CORRECT?
 - Intensities of reflections from different crystallographic planes are equal
 - According to Bragg's law higher order of reflections have high θ values for a given wavelength of radiation
 - For a given wavelength of radiation there is a smallest distance between the crystallographic planes which can be determined
 - Bragg's law may predict a reflection from a crystallographic plane to be present but it may be absent due to the crystal symmetry
- Identify the graph which correctly represents the Moseley's law
 -
 -
 -
 -
- Assuming f to be the frequency of first line in Balmer series, the frequency of the immediate next (i.e. second) line is
 - $0.50 f$
 - $1.35 f$
 - $2.05 f$
 - $2.70 f$
- The velocity of a particle at which the kinetic energy is equal to its rest energy is
 - $\left(\frac{3c}{2}\right)$
 - $3\frac{c}{\sqrt{2}}$
 - $\frac{(3c)^{\frac{1}{2}}}{2}$
 - $\frac{c\sqrt{3}}{2}$
- One electron and one proton is accelerated by equal potential. Ratio in their deBroglie wavelength is
 - 1
 - $\frac{m_e}{m_p}$
 - $\frac{m_p}{m_e}$
 - $\sqrt{\frac{m_e}{m_p}}$
- Two electrons one moving in opposite direction with speeds $0.8c$ and $0.4c$ where c is the speed of light in vacuum. Then the relative speed is about
 - $0.4c$
 - $0.8c$
 - $0.9c$
 - $1.2c$
- A photo-sensitive material would emit electrons if excited by photons beyond a threshold. To overcome the threshold, one would increase
 - the voltage applied to the light source
 - the intensity of light
 - the wavelength of light
 - the frequency of light

9. The radius of nucleus is
 (a) proportional to its mass number
 (b) inversely proportional to its mass number
 (c) proportional to the cube root of its mass number
 (d) not related to its mass number
10. Radio carbon dating is done by estimating in specimen
 (a) the amount of ordinary carbon still present
 (b) the amount of radio carbon still present
 (c) the ratio of amount of $^{14}\text{C}_6$ to $^{12}\text{C}_6$ still present
 (d) the ratio of amount of $^{12}\text{C}_6$ to $^{14}\text{C}_6$ still present
11. Ionization power and penetration range of radioactive radiation increases in the order
 (a) γ, β, α and γ, β, α respectively
 (b) γ, β, α and α, β, γ respectively
 (c) α, β, γ and α, β, γ respectively
 (d) α, β, γ and γ, β, α respectively
12. The half life of a radioactive element is 3.8 days. The fraction left after 19 days will be
 (a) 0.124 (b) 0.062
 (c) 0.093 (d) 0.031
13. Two identical P-N junctions are connected in series in three different ways as shown below to a battery. The potential drop across the P-N junctions are equal in

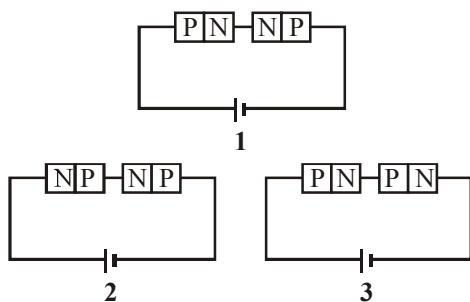

- (a) in circuits 2 and 3
 (b) in circuits 1 and 2
 (c) in circuits 1 and 3
 (d) in none of the circuit
14. The temperature coefficient of a zener mechanism is
 (a) negative (b) positive
 (c) infinity (d) zero

15. Identify the logic gate from the following TRUTH table

Inputs		Output
A	B	Y
0	0	1
0	1	0
1	0	0
1	1	0

- (a) NOR gate (b) NOT gate
 (c) AND gate (d) NAND gate
16. In Boolean algebra, $\overline{\overline{A \cdot B}}$ is equal to
 (a) $\overline{A \cdot B}$ (b) $\overline{A + B}$
 (c) A.B (d) A + B
17. Radar waves are sent towards a moving airplane and the reflected waves are received. When the airplane is moving towards the radar, the wavelength of the wave
 (a) decrease
 (b) increase
 (c) remains the same
 (d) sometimes increase or decrease
18. The transmission of high frequencies in a coaxial cable is determined by
 (a) $\frac{1}{(LC)^{1/2}}$ where L and C are inductance and capacitance
 (b) $(LC)^2$
 (c) the impedance L alone
 (d) the dielectric and skin effect
19. The output stage of a television transmitter is most likely to be a
 (a) plate-modulated class C amplifier
 (b) grid-modulated class C amplifier
 (c) screen-modulated class C amplifier
 (d) grid-modulated class A amplifier
20. The antenna current of an AM transmitter is 8A when only the carrier is sent, but it increases to 8.93A when the carrier is modulated by a single sine wave. Find the percentage modulation.
 (a) 60.1% (b) 70.1%
 (c) 80.1% (d) 50.1%

21. Two point like charges Q_1 and Q_2 of whose strength are equal in absolute value are placed at a certain distance from each other. Assuming the field strength to be positive in the positive direction of x-axis the signs of the charges Q_1 and Q_2 for the graphs (field strength versus distance) shown in Figures 1,2,3 and 4 are

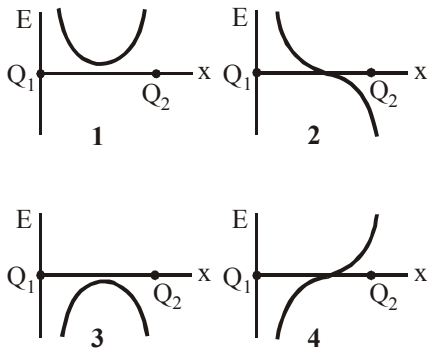

- (a) Q_1 positive, Q_2 negative; both positive; Q_1 negative, Q_2 positive; both negative
 (b) Q_1 negative, Q_2 positive; Q_1 positive, Q_2 negative; both positive; both negative
 (c) Q_1 positive, Q_2 negative; both negative; Q_1 negative, Q_2 positive; both positive
 (d) Both positive; Q_1 positive, Q_2 negative; Q_1 negative, Q_2 positive; both negative
22. ABCD is a rectangle. At corners B, C and D of the rectangle are placed charges $+10 \times 10^{-12}C$, $-20 \times 10^{-12}C$ and $10 \times 10^{-12}C$ respectively. Calculate the potential at the fourth corner. The side $AB = 4cm$ and $BC = 3cm$
- (a) 1.65 V (b) 0.165 V
 (c) 16.5 V (d) 2.65 V
23. A parallel plate capacitor of capacitance 100 pF is to be constructed by using paper sheets of 1 mm thickness as dielectric. If the dielectric constant of paper is 4, the number of circular metal foils of diameter 2 cm each required for the purpose is
- (a) 40 (b) 20
 (c) 30 (d) 10

24. The electric field intensity E , due to an electric dipole of moment \vec{p} , at a point on the equatorial line is

- (a) parallel to the axis of the dipole and opposite to the direction of the dipole moment \vec{p}
 (b) perpendicular to the axis of the dipole and is directed away from it
 (c) parallel to the dipole moment
 (d) perpendicular to the axis of the dipole and is directed toward it

25. Twelve wires of each of resistance 6 ohms are connected to form a cube as shown in the figure. The current enters at a corner A and leaves at the diagonally opposite corner G. The joint resistance across the corners A and G are

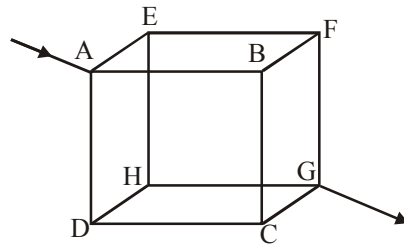

- (a) 12 ohms (b) 6 ohms
 (c) 3 ohms (d) 5 ohms
26. A conductor and a semi-conductor are connected in parallel as shown in the figure. At a certain voltage both ammeters registers the same current. If the voltage of the DC source is increased then

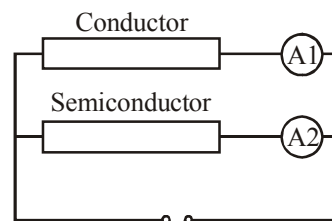

- (a) the ammeter connected to the semiconductor will register higher current than the ammeter connected to the conductor
 (b) the ammeter connected to the conductor will register higher current than the ammeter connected to the semiconductor
 (c) the ammeters connected to both semiconductor and conductor will register the same current
 (d) the ammeter connected to both semiconductor and conductor will register no change in the current

34. From figure shown below a series LCR circuit connected to a variable frequency 200V source. $L = 5\text{H}$, $C = 80\ \mu\text{F}$ and $R = 40\ \Omega$. Then the source frequency which drive the circuit at resonance is

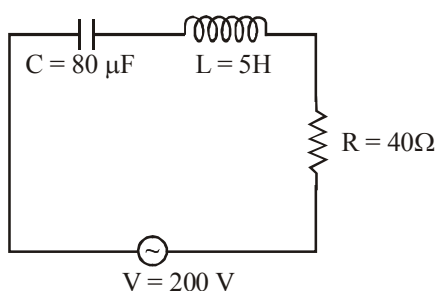

- (a) 25 Hz (b) $\frac{25}{\pi}$ Hz
- (c) 50 Hz (d) $\frac{50}{\pi}$ Hz
35. If the coefficient of mutual induction of the primary and secondary coils of an induction coil is 5H and a current of 10A is cut off in 5×10^{-4} second, the *emf* induced (in volt) in the secondary coil is
- (a) 5×10^4 (b) 1×10^5
- (c) 25×10^5 (d) 5×10^6
36. A voltage of peak value 283 V and varying frequency is applied to a series L, C, R combination in which $R = 3\ \text{ohm}$, $L = 25\ \text{mH}$ and $C = 400\ \mu\text{F}$. The frequency (in Hz) of the source at which maximum power is dissipated in the above is
- (a) 51.5 (b) 50.7
- (c) 51.1 (d) 50.3
37. Four independent waves are represented by equations
- (1) $X_1 = a_1 \sin \omega t$ (3) $X_2 = a_2 \sin 2\omega t$
- (2) $X_3 = a_1 \sin \omega_1 t$ (4) $X_4 = a_1 \sin(\omega t + \delta)$
- Interference is possible between waves represented by equations
- (a) 3 and 4 (b) 1 and 2
- (c) 2 and 3 (d) 1 and 4

38. Following diffraction pattern was obtained using a diffraction grating using two different wavelengths λ_1 and λ_2 . With the help of the figure identify which is the longer wavelength and their ratios.

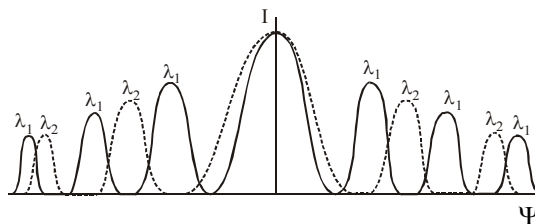

- (a) λ_2 is longer than λ_1 and the ratio of the longer to the shorter wavelength is 1.5
- (b) λ_1 is longer than λ_2 and the ratio of the longer to the shorter wavelength is 1.5
- (c) λ_1 and λ_2 are equal and their ratio is 1.0
- (d) λ_2 is longer than λ_1 and the ratio of the longer to the shorter wavelength is 2.5
39. In Young's double slit experiment, the interference pattern is found to have an intensity ratio between bright and dark fringes is 9. This implies the
- (a) the intensities at the screen due to two slits are 5 units and 4 units respectively
- (b) the intensities at the screen due to the two slits are 4 units and 1 units respectively
- (c) the amplitude ratio is 7
- (d) the amplitude ratio is 6
40. Rising and setting sun appears to be reddish because
- (a) Diffraction sends red rays to earth at these times
- (b) Scattering due to dust particles and air molecules are responsible
- (c) Refraction is responsible
- (d) Polarization is responsible

PART - II (CHEMISTRY)

41. The catalyst used in Rosenmund reaction is
- (a) Zn / Hg (b) Pd / BaSO₄
- (c) Raney Ni (d) Na in Ethanol
42. $(\text{CH}_2\text{CO})_2\text{O} + \text{RMgX} \xrightarrow{\text{H}_2\text{O}} ?$
- (a) ROOC(CH₂)COOR
- (b) RCOCH₂CH₂COOH
- (c) RCOOR
- (d) RCOOH

43. Identify, which of the below does not possess any element of symmetry?
 (a) (+)- Tartaric acid
 (b) Carbon tetrachloride
 (c) Methane
 (d) Mesotartaric acid
44. The weakest acid amongst the following is
 (a) ClCH_2COOH (b) HCOOH
 (c) $\text{FCH}_2\text{CH}_2\text{COOH}$ (d) $\text{CH}_2(\text{I})\text{COOH}$
45. $\text{HOOC}-(\text{CH}_2)_4-\text{COOH} + 2\text{C}_2\text{H}_5\text{OH}$
 $\xrightarrow[\text{Toluene}]{\text{H}_2\text{SO}_4} \text{C}_2\text{H}_5\text{OOC}-\text{CH}_2-\text{COOC}_2\text{H}_5$
 The purpose of using toluene here is
 (a) to make both substances (acid & alcohol) miscible
 (b) that the product is insoluble in toluene
 (c) that the reactants are insoluble in water
 (d) because of the formation of low boiling azeotrope
46. Trans esterification is the process of
 (a) conversion of an aliphatic acid to ester
 (b) conversion of an aromatic acid to ester
 (c) conversion of one ester to another ester
 (d) conversion of an ester into its components namely acid and alcohol
47. The correct sequence of base strengths in aqueous solution is
 (a) $(\text{CH}_3)_2\text{NH} > \text{CH}_3\text{NH}_2 > (\text{CH}_3)_3\text{N}$
 (b) $(\text{CH}_3)_3\text{N} > (\text{CH}_3)_2\text{NH} > \text{CH}_3\text{NH}_2$
 (c) $(\text{CH}_3)_3\text{N} > \text{CH}_3\text{NH}_2 = (\text{CH}_3)_2\text{NH}$
 (d) $(\text{CH}_3)_2\text{NH} > (\text{CH}_3)_3\text{N} > \text{CH}_3\text{NH}_2$
48. When aqueous solution of benzene diazonium chloride is boiled, the product formed is
 (a) $\text{C}_6\text{H}_5\text{CH}_2\text{OH}$ (b) $\text{C}_6\text{H}_6 + \text{N}_2$
 (c) $\text{C}_6\text{H}_5\text{COOH}$ (d) $\text{C}_6\text{H}_5\text{OH}$
49. Carbylamine reaction is given by aliphatic
 (a) primary amine
 (b) secondary amine
 (c) tertiary amine
 (d) quaternary ammonium salt
50. $\text{C}_6\text{H}_5\text{CHO} \xrightarrow[\text{H}_2, \text{Ni}]{\text{NH}_3} ?$
 (a) $\text{C}_6\text{H}_5\text{NH}_2$ (b) $\text{C}_6\text{H}_5\text{NHCH}_3$
 (c) $\text{C}_6\text{H}_5\text{CH}_2\text{NH}_2$ (d) $\text{C}_6\text{H}_5\text{NHC}_6\text{H}_5$
51. In TeCl_4 the central atom tellurium involves
 (a) sp^3 hybridization
 (b) sp^3d hybridization
 (c) sp^3d^2 hybridization
 (d) dsp^2 hybridization
52. The purple colour of KMnO_4 is due to the transition
 (a) C.T. (L→M) (b) C.T. (M→L)
 (c) d-d (d) p-d
53. A nuclear reaction of $^{235}_{92}\text{U}$ with a neutron produces $^{90}_{36}\text{Kr}$ and two neutrons. Other element produced in this reaction is
 (a) $^{137}_{52}\text{Te}$ (b) $^{144}_{55}\text{Cs}$
 (c) $^{137}_{56}\text{Ba}$ (d) $^{144}_{56}\text{Ba}$
54. AgCl dissolves in a solution of NH_3 but not in water because
 (a) NH_3 is a better solvent than H_2O
 (b) Ag^+ forms a complex ion with NH_3
 (c) NH_3 is a stronger base than H_2O
 (d) the dipole moment of water is higher than NH_3
55. Which of the following is hexadentate ligand?
 (a) Ethylene diamine
 (b) Ethylene diamine tetra acetic acid
 (c) 1, 10-phenanthroline
 (d) Acetyl acetonato
56. A coordinate bond is a dative covalent bond. Which of the below is true?
 (a) Three atoms form bond by sharing their electrons
 (b) Two atoms form bond by sharing their electrons
 (c) Two atoms form bond and one of them provides both electrons
 (d) Two atoms form bond by sharing electrons obtained from third atom
57. Which of the following complex has zero magnetic moment (spin only)?
 (a) $[\text{Ni}(\text{NH}_3)_6]\text{Cl}_2$ (b) $\text{Na}_3[\text{FeF}_6]$
 (c) $[\text{Cr}(\text{H}_2\text{O})_6]\text{SO}_4$ (d) $\text{K}_4[\text{Fe}(\text{CN})_6]$
58. The IUPAC name of $[\text{Ni}(\text{PPh}_3)_2\text{Cl}_2]^{2+}$ is
 (a) bis dichloro (triphenylphosphine) nickel (II)
 (b) dichloro bis (triphenylphosphine) nickel (II)
 (c) dichloro triphenylphosphine nickel (II)
 (d) triphenyl phosphine nickel (II) dichloride

59. Among the following the compound that is both paramagnetic and coloured is
 (a) $K_2Cr_2O_7$ (b) $(NH_4)_2[TiCl_6]$
 (c) $VOSO_4$ (d) $K_3Cu(CN)_4$
60. On an X-ray diffraction photograph the intensity of the spots depends on
 (a) neutron density of the atoms/ions
 (b) electron density of the atoms/ions
 (c) proton density of the atoms/ions
 (d) photon density of the atoms/ions
61. An ion leaves its regular site occupy a position in the space between the lattice sites is called
 (a) Frenkel defect (b) Schottky defect
 (c) Impurity defect (d) Vacancy defect
62. The 8:8 type of packing is present in
 (a) MgF_2 (b) $CsCl$
 (c) KCl (d) $NaCl$
63. When a solid melts reversibly
 (a) H decreases (b) G increases
 (c) E decreases (d) S increases
64. Enthalpy is equal to
 (a) $-T^2 \left[\frac{\delta(\Delta G)}{\delta T} \right]_V$ (b) $-T^2 \left[\frac{\delta(G/T)}{\delta T} \right]_P$
 (c) $T^2 \left[\frac{\delta(G/T)}{\delta T} \right]_V$ (d) $-T^2 \left[\frac{\delta(\Delta G)}{\delta T} \right]_P$
65. Condition for spontaneity in an isothermal process is
 (a) $\Delta A + W < 0$ (b) $\Delta G + U < 0$
 (c) $\Delta A + U > 0$ (d) $\Delta G - U < 0$
66. Given: $2C(s) + 2O_2(g) \rightarrow 2CO_2(g)$;
 $\Delta H = -787 \text{ kJ}$
 $H_2(g) + \frac{1}{2}O_2(g) \rightarrow H_2O(l)$; $\Delta H = -286 \text{ kJ}$
 $C_2H_2(g) + 2\frac{1}{2}O_2(g) \rightarrow 2CO_2(g) + H_2O(l)$
 $;\Delta H = -1310 \text{ kJ}$
 The heat of formation of acetylene is
 (a) -1802 kJ (b) $+1802 \text{ kJ}$
 (c) $+237 \text{ kJ}$ (d) -800 kJ
67. Given the equilibrium system:
 $NH_4Cl(s) \rightarrow NH_4^+(aq) + Cl^-(aq)$
 ($\Delta H = +3.5 \text{ kcal/mol}$).
 What change will shift the equilibrium to the right?
 (a) Decreasing the temperature
 (b) Increasing the temperature
 (c) Dissolving $NaCl$ crystals in the equilibrium mixture
 (d) Dissolving NH_4NO_3 crystals in the equilibrium mixture
68. According to Arrhenius equation, the rate constant (k) is related to temperature (T) as
 (a) $\ln \frac{k_2}{k_1} = \frac{E_a}{R} \left[\frac{1}{T_1} - \frac{1}{T_2} \right]$
 (b) $\ln \frac{k_2}{k_1} = -\frac{E_a}{R} \left[\frac{1}{T_1} - \frac{1}{T_2} \right]$
 (c) $\ln \frac{k_2}{k_1} = \frac{E_a}{R} \left[\frac{1}{T_1} + \frac{1}{T_2} \right]$
 (d) $\ln \frac{k_2}{k_1} = -\frac{E_a}{R} \left[\frac{1}{T_1} + \frac{1}{T_2} \right]$
69. Equivalent amounts of H_2 and I_2 are heated in a closed vessel till equilibrium is obtained. If 80% of the hydrogen can be converted to HI , the K_c at this temperature is
 (a) 64 (b) 16
 (c) 0.25 (d) 4
70. For the reaction $H_2(g) + I_2(g) \rightarrow 2HI(g)$, the equilibrium constant K_p changes with
 (a) total pressure
 (b) catalyst
 (c) the amount H_2 and I_2
 (d) temperature
71. How long (in hours) must a current of 5.0 amperes be maintained to electroplate 60g of calcium from molten $CaCl_2$?
 (a) 27 hours (b) 8.3 hours
 (c) 11 hours (d) 16 hours
72. For strong electrolytes the plot of molar conductance vs \sqrt{C} is
 (a) parabolic (b) linear
 (c) sinusoidal (d) circular

73. If the molar conductance values of Ca^{2+} and Cl^- at infinite dilution are respectively $118.88 \times 10^{-4} \text{ m}^2 \text{ mho mol}^{-1}$ and $77.33 \times 10^{-4} \text{ m}^2 \text{ mho mol}^{-1}$ then that of CaCl_2 is (in $\text{m}^2 \text{ mho mol}^{-1}$)
 (a) 118.88×10^{-4} (b) 154.66×10^{-4}
 (c) 273.54×10^{-4} (d) 196.21×10^{-4}
74. The standard reduction potentials at 298K for the following half reactions are given against each
 $\text{Zn}^{2+}(\text{aq}) + 2\text{e}^- \rightarrow \text{Zn}(\text{s}) \quad E_0 = -0.762 \text{ V}$
 $\text{Cr}^{3+}(\text{aq}) + 3\text{e}^- \rightarrow \text{Cr}(\text{s}) \quad E_0 = -0.740 \text{ V}$
 $2\text{H}^+(\text{aq}) + 2\text{e}^- \rightarrow \text{H}_2(\text{g}) \quad E_0 = 0.00 \text{ V}$
 $\text{Fe}^{3+}(\text{aq}) + 3\text{e}^- \rightarrow \text{Fe}^{2+}(\text{aq}) \quad E_0 = +0.762 \text{ V}$
 The strongest reducing agent is
 (a) $\text{Zn}(\text{s})$ (b) $\text{Cr}(\text{s})$
 (c) $\text{H}_2(\text{g})$ (d) $\text{Fe}^{2+}(\text{aq})$
75. The epoxide ring consists of which of the following?
 (a) Three membered ring with two carbon and one oxygen
 (b) Four membered ring with three carbon and one oxygen
 (c) Five membered ring with four carbon and one oxygen
 (d) Six membered ring with five carbon and one oxygen
76. In the Grignard reaction, which metal forms an organometallic bond?
 (a) Sodium (b) Titanium
 (c) Magnesium (d) Palladium
77. Phenol is less acidic than
 (a) p-chlorophenol
 (b) p-nitrophenol
 (c) p-methoxyphenol
 (d) ethanol
78. Aldol condensation is given by
 (a) trimethylacetaldehyde
 (b) acetaldehyde
 (c) benzaldehyde
 (d) formaldehyde
79. Give the IUPAC name for

$$\text{H}_3\text{C}-\text{CH}_2-\overset{\text{O}}{\parallel}{\text{C}}-\text{H}_2\text{C}-\text{CH}_2-\overset{\text{O}}{\parallel}{\text{C}}-\text{OCH}_3$$

 (a) Ethyl-4-oxoheptonate
 (b) Methyl-4-oxoheptonate
 (c) Ethyl-4-oxohexonate
 (d) Methyl-4-oxohexonate
80. In which of the below reaction do we find α, β -unsaturated carbonyl compounds undergoing a ring closure reaction with conjugated dienes?
 (a) Perkin reaction
 (b) Diels-Alder reaction
 (c) Claisen rearrangement
 (d) Hoffman reaction

PART - III (MATHEMATICS)

81. Let the pairs \vec{a}, \vec{b} and \vec{c}, \vec{d} each determine a plane. Then the planes are parallel if
 (a) $(\vec{a} \times \vec{c}) \times (\vec{b} \times \vec{d}) = \vec{0}$
 (b) $(\vec{a} \times \vec{c}) \cdot (\vec{b} \times \vec{d}) = 0$
 (c) $(\vec{a} \times \vec{b}) \times (\vec{c} \times \vec{d}) = \vec{0}$
 (d) $(\vec{a} \times \vec{b}) \cdot (\vec{c} \times \vec{d}) = \vec{0}$
82. The area of a parallelogram with $3\hat{i} + \hat{j} - 2\hat{k}$ and $\hat{i} - 3\hat{j} + 4\hat{k}$ as diagonals is
 (a) $\sqrt{72}$ (b) $\sqrt{73}$
 (c) $\sqrt{74}$ (d) $\sqrt{75}$
83. If $\cos x + \cos^2 x = 1$ then the value of $\sin^{12} x + 3\sin^{10} x + 3\sin^8 x + \sin^6 x - 1$ is equal to
 (a) 2 (b) 1
 (c) -1 (d) 0
84. The product of all values of $(\cos \alpha + i \sin \alpha)^{3/5}$ is equal to
 (a) 1 (b) $\cos \alpha + i \sin \alpha$
 (c) $\cos 3\alpha + i \sin 3\alpha$ (d) $\cos 5\alpha + i \sin 5\alpha$
85. The imaginary part of $\frac{(1+i)^2}{i(2i-1)}$ is
 (a) $\frac{4}{5}$ (b) 0
 (c) $\frac{2}{5}$ (d) $-\frac{4}{5}$

86. If $\sin^{-1} x + \sin^{-1} y = \frac{\pi}{2}$, then $\cos^{-1} x + \cos^{-1} y$ is equal to
- (a) $\frac{\pi}{2}$ (b) $\frac{\pi}{4}$
(c) π (d) $\frac{3\pi}{4}$
87. The equation of a directrix of the ellipse $\frac{x^2}{16} + \frac{y^2}{25} = 1$ is
- (a) $3y = 5$ (b) $y = 5$
(c) $3y = 25$ (d) $y = 3$
88. If the normal at $(ap^2, 2ap)$ on the parabola $y^2 = 4ax$, meets the parabola again at $(aq^2, 2aq)$, then
- (a) $p^2 + pq + 2 = 0$ (b) $p^2 - pq + 2 = 0$
(c) $q^2 + pq + 2 = 0$ (d) $p^2 + pq + 1 = 0$
89. The length of the straight line $x - 3y = 1$ intercepted by the hyperbola $x^2 - 4y^2 = 1$ is
- (a) $\sqrt{10}$ (b) $\frac{6}{5}$
(c) $\frac{1}{\sqrt{10}}$ (d) $\frac{6}{5}\sqrt{10}$
90. The curve described parametrically by $x = t^2 + 2t - 1$, $y = 3t + 5$ represents
- (a) an ellipse (b) a hyperbola
(c) a parabola (d) a circle
91. If the normal to the curve $y = f(x)$ at $(3, 4)$ makes an angle $\frac{3\pi}{4}$ with the positive x-axis, then $f'(3)$ is equal to
- (a) -1 (b) $\frac{3}{4}$
(c) 1 (d) $-\frac{3}{4}$
92. The function $f(x) = x^2 e^{-2x}$, $x > 0$. Then the maximum value of $f(x)$ is
- (a) $\frac{1}{e}$ (b) $\frac{1}{2e}$
(c) $\frac{1}{e^2}$ (d) $\frac{4}{e^4}$
93. If $(x+y)\sin u = x^2y^2$, then $x \frac{\partial u}{\partial x} + y \frac{\partial u}{\partial y} =$
- (a) $\sin u$ (b) $\operatorname{cosec} u$
(c) $2 \tan u$ (d) $\tan u$
94. The angle between the tangents at those points on the curve $x = t^2 + 1$ and $y = t^2 - t - 6$ where it meets x-axis is
- (a) $\pm \tan^{-1}\left(\frac{4}{29}\right)$ (b) $\pm \tan^{-1}\left(\frac{5}{49}\right)$
(c) $\pm \tan^{-1}\left(\frac{10}{49}\right)$ (d) $\pm \tan^{-1}\left(\frac{8}{29}\right)$
95. The value of $\int_1^4 |x-3| dx$ is equal to
- (a) 2 (b) $\frac{5}{2}$
(c) $\frac{1}{2}$ (d) $\frac{3}{2}$
96. The area of the region bounded by the straight lines $x = 0$ and $x = 2$ and the curves $y = 2^x$ and $y = 2x - x^2$ is equal to
- (a) $\frac{2}{\log 2} - \frac{4}{3}$ (b) $\frac{3}{\log 2} - \frac{4}{3}$
(c) $\frac{1}{\log 2} - \frac{4}{3}$ (d) $\frac{4}{\log 2} - \frac{3}{2}$
97. The value of $\int_0^{\infty} \frac{dx}{(a^2 + x^2)^7}$ is equal to
- (a) $\frac{231}{2047} \left(\frac{1}{a^{13}}\right)$ (b) $\frac{235}{2048} \left(\frac{1}{a^{13}}\right)$
(c) $\frac{232}{2047} \left(\frac{1}{a^{13}}\right)$ (d) $\frac{231}{2048} \left(\frac{1}{a^{13}}\right)$

98. The value of the integral $\int e^x \left(\frac{1-x}{1+x^2} \right)^2 dx$ is

(a) $e^x \left(\frac{1-x}{1+x^2} \right) + C$

(b) $e^x \left(\frac{1+x}{1+x^2} \right) + C$

(c) $\frac{e^x}{1+x^2} + C$

(d) $e^x(1-x) + C$

99. If $x \sin\left(\frac{y}{x}\right) dy = \left[y \sin\left(\frac{y}{x}\right) - x \right] dx$

and $y(1) = \frac{\pi}{2}$, then the value of $\cos\left(\frac{y}{x}\right)$ is

equal to

(a) x (b) $\frac{1}{x}$

(c) $\log x$ (d) e^x

100. The differential equation of the system of all circles of radius r in the XY plane is

(a) $\left[1 + \left(\frac{dy}{dx} \right)^3 \right]^2 = r^2 \left(\frac{d^2y}{dx^2} \right)^2$

(b) $\left[1 + \left(\frac{dy}{dx} \right)^3 \right]^2 = r^2 \left(\frac{d^2y}{dx^2} \right)^3$

(c) $\left[1 + \left(\frac{dy}{dx} \right)^2 \right]^3 = r^2 \left(\frac{d^2y}{dx^2} \right)^2$

(d) $\left[1 + \left(\frac{dy}{dx} \right)^2 \right]^3 = r^2 \left(\frac{d^2y}{dx^2} \right)^3$

101. The general solution of the differential equation

$$\frac{d^2y}{dx^2} + 2 \frac{dy}{dx} + y = 2e^{3x}$$

is given by

(a) $y = (c_1 + c_2x)e^x + \frac{e^{3x}}{8}$

(b) $y = (c_1 + c_2x)e^{-x} + \frac{e^{-3x}}{8}$

(c) $y = (c_1 + c_2x)e^{-x} + \frac{e^{3x}}{8}$

(d) $y = (c_1 + c_2x)e^x + \frac{e^{-3x}}{8}$

102. The solution of the differential equation $yx + (x-y^3)dy = 0$ is

(a) $xy = \frac{1}{3}y^3 + C$ (b) $xy = y^4 + C$

(c) $y^4 = 4xy + C$ (d) $4y = y^3 + C$

103. The number of positive integral solutions of the equation $x_1 x_2 x_3 x_4 x_5 = 1050$ is

(a) 1870 (b) 1875

(c) 1865 (d) 1880

104. Let $A = \{1, 2, 3, \dots, n\}$ and $B = \{a, b, c\}$, then the number of functions from A to B that are onto is

(a) $3^n - 2^n$ (b) $3^n - 2^{n-1}$

(c) $3(2^n - 1)$ (d) $3^n - 3(2^n - 1)$

105. Everybody in a room shakes hands with everybody else. The total number of hand shakes is 66. The total number of persons in the room is

(a) 9 (b) 12

(c) 10 (d) 14

106. If $(G, *)$ is a group and the order of an element $a \in G$ is 10, then the order of the inverse of $a^* a$ is

(a) 10 (b) $\frac{1}{10}$

(c) 5 (d) $\frac{1}{5}$

107. A box contains 9 tickets numbered 1 to 9 inclusive. If 3 tickets are drawn from the box one at a time, the probability that they are alternatively either {odd, even, odd} or {even, odd, even} is

(a) $\frac{5}{17}$ (b) $\frac{4}{17}$

(c) $\frac{5}{16}$ (d) $\frac{5}{18}$

108. If $P(A) = \frac{1}{12}$, $P(B) = \frac{5}{12}$ and $P(B/A) = \frac{1}{15}$ then $p(A \cup B)$ is equal to

- (a) $\frac{89}{180}$ (b) $\frac{90}{180}$
 (c) $\frac{91}{180}$ (d) $\frac{92}{180}$

109. If the probability density function of a random variable X is $f(x) = \frac{x}{2}$ in $0 \leq x \leq 2$, then $P(X > 1.5 | X > 1)$ is equal to

- (a) $\frac{7}{16}$ (b) $\frac{3}{4}$
 (c) $\frac{7}{12}$ (d) $\frac{21}{64}$

110. If X is a poisson variate such that $2P(X=0) + P(X=2) = 2P(X=1)$ then $E(X)$ is equal to

- (a) 1 (b) 2
 (c) 1.5 (d) 1.75

111. If $A(\theta) = \begin{bmatrix} 1 & \tan \theta \\ -\tan \theta & 1 \end{bmatrix}$ and $AB = I$, then $(\cos^2 \theta)B$ is equal to

- (a) $A(\theta)$ (b) $A\left(\frac{\theta}{2}\right)$
 (c) $A(-\theta)$ (d) $A\left(\frac{-\theta}{2}\right)$

112. If $x = -5$ is a root of $\begin{vmatrix} 2x+1 & 4 & 8 \\ 2 & 2x & 2 \\ 7 & 6 & 2x \end{vmatrix} = 0$, then

- the other roots are
 (a) 3, 3.5 (b) 1, 3.5
 (c) 1, 7 (d) 2, 7

113. The simultaneous equations $Kx + 2y - z = 1$, $(K-1)y - 2z = 2$ and $(K+2)z = 3$ have only one solution when

- (a) $K = -2$ (b) $K = -1$
 (c) $K = 0$ (d) $K = 1$

114. If the rank of the matrix $\begin{pmatrix} -1 & 2 & 5 \\ 2 & -4 & a-4 \\ 1 & -2 & a+1 \end{pmatrix}$ is 1,

then the value of a is

- (a) -1 (b) 2
 (c) -6 (d) 4

115. If $b^2 \geq 4ac$ for the equation $ax^4 + bx^2 + c = 0$, then all the roots of the equation will be real if

- (a) $b > 0, a < 0, c > 0$ (b) $b < 0, a > 0, c > 0$
 (c) $b > 0, a > 0, c > 0$ (d) $b > 0, a > 0, c < 0$

116. If $x > 0$ and $\log_3 x + \log_3(\sqrt{x}) + \log_3(\sqrt[4]{x}) + \log_3(\sqrt[8]{x}) + \log_3(\sqrt[16]{x}) + \dots = 4$, then x equals

- (a) 9 (b) 81
 (c) 1 (d) 27

117. The number of real roots of the equation

$$\left(x + \frac{1}{x}\right)^3 + x + \frac{1}{x} = 0$$
 is

- (a) 0 (b) 2
 (c) 4 (d) 6

118. If H is the harmonic mean between P and Q , then the value of $\frac{H}{P} + \frac{H}{Q}$ is

- (a) 2 (b) $\frac{PQ}{P+Q}$
 (c) $\frac{1}{2}$ (d) $\frac{P+Q}{PQ}$

119. If \vec{a} and \vec{b} are two unit vectors, then the vector $(\vec{a} + \vec{b}) \times (\vec{a} \times \vec{b})$ is parallel to the vector

- (a) $\vec{a} + \vec{b}$ (b) $2\vec{a} + \vec{b}$
 (c) $\vec{a} - \vec{b}$ (d) $2\vec{a} - \vec{b}$

120. If θ is the angle between the lines AB and AC where A, B and C are the three points with coordinates $(1, 2, -1), (2, 0, 3), (3, -1, 2)$ respectively, then $\sqrt{462} \cos \theta$ is equal to

- (a) 20 (b) 10
 (c) 30 (d) 40

2007 SOLUTIONS

PART - I (PHYSICS)

1. (d) The magnetic moment of the ground state of an atom whose open sub-shell is half filled with n electrons is given by

$$\mu = \sqrt{n(n+2)} \cdot \mu_B$$

where μ_B is the gyromagnetic moment of the atom.

Here, $n = 5$.

$$\therefore \mu = \sqrt{5(5+2)} \cdot \mu_B = \sqrt{35} \mu_B$$

2. (a) Bragg's law gives $2d \sin \theta = n\lambda$, $n =$ order of reflection, $d =$ distance between planes. For same λ and d , $n \propto \theta$; for a given λ , smallest d for least n , θ can be found. If crystal is symmetric reflections from different planes may cancel out.

3. (b) According to Moseley's law, square root of frequency of X-ray is plotted against atomic number it gives straight line, the relation is

$$\sqrt{f} = c(Z-1) \text{ where } c = \text{constant}$$

(for $\sqrt{f} = 0, Z = +c$, for $Z = 0, \sqrt{f} = -c$)

\therefore Option (b) is correct. as Z can not be negative.

4. (b) Balmer series is given for $n_1 = 2$ and $n_2 = 3, 4, \dots$

$$v = Rc \left[\frac{1}{2^2} - \frac{1}{n_2^2} \right]$$

For 1st line in spectrum $n_2 = 3$

$$v_1 = Rc \left[\frac{1}{2^2} - \frac{1}{n_2^2} \right] = Rc \left[\frac{1}{4} - \frac{1}{9} \right] = f$$

$$\Rightarrow f = \frac{5}{36} Rc \Rightarrow Rc = \frac{36}{5} f$$

For second line $n_2 = 4$

$$\begin{aligned} v_2 &= Rc \left[\frac{1}{2^2} - \frac{1}{4^2} \right] = Rc \left[\frac{1}{4} - \frac{1}{16} \right] \\ &= Rc \left[\frac{4-1}{16} \right] \end{aligned}$$

$$v_2 = \frac{3}{16} Rc = \frac{3}{16} \times \frac{36}{5} f = 1.35f.$$

5. (d) Here, Kinetic energy = Rest energy
we know that

$$\text{Kinetic energy (Relativistic)} = (m - m_0)c^2,$$

$$\text{and Rest energy} = m_0c^2,$$

where $m_0 =$ rest mass, $c =$ velocity of light

Also, mass (m) of a particle moving with velocity v is given by

$$m = \frac{m_0}{\sqrt{1 - \left(\frac{v^2}{c^2}\right)}}$$

$$\therefore (m - m_0)c^2 = m_0c^2 \text{ provides}$$

$$\left(\frac{m_0}{\sqrt{1 - \left(\frac{v^2}{c^2}\right)}} - m_0 \right) c^2 = m_0c^2$$

$$\text{or, } \frac{1}{\sqrt{1 - \left(\frac{v^2}{c^2}\right)}} - 1 = 1$$

$$\text{or, } \frac{1}{\sqrt{1 - \left(\frac{v^2}{c^2}\right)}} = 2 \quad \text{or, } 1 - \frac{v^2}{c^2} = \frac{1}{4}$$

$$\text{or, } \frac{v^2}{c^2} = 1 - \frac{1}{4} = \frac{3}{4}$$

$$\therefore v = \frac{\sqrt{3}}{2} c.$$

$$\Rightarrow 1 - \frac{v^2}{c^2} = \frac{1}{4}$$

$$\Rightarrow \frac{v^2}{c^2} = 1 - \frac{1}{4} = \frac{3}{4} \Rightarrow v^2 = \frac{3}{4} c^2$$

$$\Rightarrow v = \sqrt{\frac{3}{4}} c$$

6. (d) de-Broglie wavelength (λ) of a particle of mass m and moving with a velocity v is given by, $\lambda = \frac{h}{mv}$, where h is Planck's constant.

When a particle having charge q is accelerated through a potential V then

$$qV = \frac{1}{2}mv^2$$

$$\text{or, } qV = \frac{m^2v^2}{2m} \Rightarrow mv = \sqrt{2mqV}$$

$$\therefore \lambda = \frac{h}{\sqrt{2mqV}}$$

Hence, de-Broglie wavelength of electron,

$$\lambda_e = \frac{h}{\sqrt{2m_e eV}}$$

and de-Broglie wavelength of proton,

$$\lambda_p = \frac{h}{\sqrt{2m_p eV}}, \text{ where } e \text{ represents the}$$

charge of electron (or proton)

$$\therefore \frac{\lambda_e}{\lambda_p} = \sqrt{\left(\frac{m_p}{m_e}\right)}$$

7. (c) Relative speed is given by

$$u = \frac{u' + v}{1 + \frac{u'v}{c^2}}$$

Here, $u' = 0.8c$ and $v = 0.4c$

$$\therefore u = \frac{0.8c + 0.4c}{1 + \frac{(0.8c)(0.4c)}{c^2}} = \frac{1.2c}{1.32} = 0.9c.$$

8. (d) By Einstein's equation, photoemission occurs when $h\nu > \phi_0$ or $h\nu > h\nu_0$ i.e., frequency of incident photon is greater than threshold frequency.

9. (c) Radius of nucleus is given by $R \propto A^{1/3}$
 $R = R_0 A^{1/3}$, where A = mass number

10. (c) Radio carbon dating is done by measuring ratio of ^{14}C present in the sample, since proportion of ^{14}C and ^{12}C in a body is same; but after death ^{14}C decays. Hence knowing the present ratio of ^{14}C to ^{12}C , sample can be dated.

11. (b) α particles are positively charged He nucleus, it can accept $2e^-$, β rays are negatively charged which are similar to e^- , can donate $1e^-$, γ are radiations. Hence ionisation power of α is maximum. γ are most energetic and α is least energetic \therefore Penetration power of γ is maximum

12. (d) Given half life $T = 3.8$ days; $t = 19$ days

$$\frac{N}{N_0} = ? \text{ now } \frac{t}{T} = \frac{19}{3.8} = 5$$

$$\Rightarrow \frac{N}{N_0} = \left(\frac{1}{2}\right)^{\frac{t}{T}} = \left(\frac{1}{2}\right)^5 = \frac{1}{32}$$

$$\Rightarrow N = \frac{N_0}{32} = 0.03 N_0$$

13. (a) If the p-n junctions are identical, then their resistances would be same. In circuit 1, the first p-n junction is forward biased and second is reverse biased. Hence the voltages across them would be different. In circuit 2 both are reverse biased. So potential drop would be same. In circuit 3 both are forward biased; again voltages would be same.

14. (a) Zener diode is a semiconductor device and for semiconductors, temperature coefficient is negative

15. (a) The truth table corresponds to the logic $\overline{A+B}$ hence it is NOR gate.

16. (d) $\overline{\overline{A.B}}$ in Boolean algebra, can be written as $\overline{\overline{A.B}} = \overline{\overline{A} + \overline{B}} = A + B$

17. (a) By Dopplers effect, if source moves towards the observer, frequency received will increase.

$$As \ v \propto \frac{1}{\lambda}$$

\therefore wavelength will decrease.

18. (d) A coaxial cable consists of a conducting wire surrounded by a dielectric space, over which there is a sleeve of coppermesh covered with a shield of PVC insulation. The power transmission is regulated by dielectric. At high frequencies energy loss due to mesh is significant (called skin effect).

19. (b) Due to their inherent distortion, plate-modulated class C amplifiers are not used as audio amplifiers. Also, class A amplifiers are not used owing to low efficiency. A grid-modulated amplifier has very high frequency. Therefore, in output stage of a TV transmitter, grid-modulated class C amplifier is used.

20. (b) The rms value of carrier current is $I_c = 8A$.
The rms value of modulated current
 $= I_c + I_m = 8.93 A = I_t$
Percentage modulation $= m_a \times 100$
The current relation in AM wave is

$$\frac{I_t^2}{I_c^2} = 1 + \frac{m_a^2}{2} \Rightarrow m_a = \sqrt{\left(\frac{I_t^2}{I_c^2} - 1\right)2}$$

$$\Rightarrow \text{Modulation index, } m_a = \sqrt{\left(\frac{(8.93)^2}{8^2} - 1\right)2}$$

$$= \sqrt{\left(\frac{79.7}{64} - 1\right)2} = \sqrt{(1.24 - 1)2}$$

$$= 0.701$$

$$\text{Percentage modulation} = m_a \times 100 = 70.1\%$$

21. (d) For a point charge, $E \propto \frac{1}{x^2}$. For positive charges, electric field will decrease in positive direction as distance increases, (case 1), for negative charge, as distance increases field will increase (case 4). As we move from positive charge to negative charge, field will keep on decreasing (case 2), As we move from negative to positive charge, field will keep on increasing (case 3)

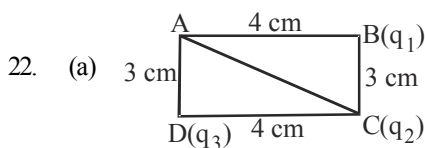

$$AC = \sqrt{4^2 + 3^2} = \sqrt{25} = 5\text{cm.}$$

$$\therefore \text{Potential at A} = V_B + V_C + V_D.$$

$$\therefore V_A = \frac{1}{4\pi\epsilon_0} \left(\frac{q_1}{AB} + \frac{q_2}{AC} + \frac{q_3}{AD} \right)$$

$$V_A = 9 \times 10^9 \left(\frac{10 \times 10^{-12}}{4 \times 10^{-2}} + \frac{-20 \times 10^{-12}}{5 \times 10^{-2}} + \frac{10 \times 10^{-12}}{3 \times 10^{-2}} \right)$$

$$= 9 \times 10^9 \times 10^{-10} \left(\frac{10}{4} + \frac{-20}{5} + \frac{10}{3} \right)$$

$$= 0.9 \left(\frac{150 - 240 + 200}{60} \right)$$

$$= \frac{0.9 \times 110}{60} = 1.65V$$

23. (d) The capacitance (C) of a parallel plate capacitor with dielectric is given by

$$C = \frac{\epsilon_0 A}{d - t \left(1 - \frac{1}{K} \right)}$$

$$C = 100 \text{ pF} = 100 \times 10^{-12} \text{ F}, \epsilon_0 = 8.85 \times 10^{-12},$$

$$A = \pi r^2 = 3.14 \times (10^{-2})^2 \text{ (r = lcm)}$$

$$t = 10^{-3} \text{ m, } d = t, K = 4$$

$$C_1 = \frac{8.85 \times 10^{-12} \times 3.14 \times 10^{-4}}{10^{-3} - 10^{-3} \left(1 - \frac{1}{4} \right)}$$

$$= \frac{27.79 \times 10^{-16}}{10^{-3} - 0.75 \times 10^{-3}}$$

$$= \frac{27.79 \times 10^{-13}}{0.25}$$

$$= \frac{27.79 \times 10^{-13}}{0.25} = 111.16 \times 10^{-13} \text{ F}$$

(for 1 set)

$$\text{Required } C = 100 \times 10^{-12} \text{ F}$$

$$\Rightarrow n = \frac{C}{C_1} = \frac{100 \times 10^{-12}}{111.16 \times 10^{-13}} \approx 10$$

24. (a) The resultant intensity at a point on equatorial line is \vec{E} . \vec{E} is parallel and opposite to direction of \vec{p} .

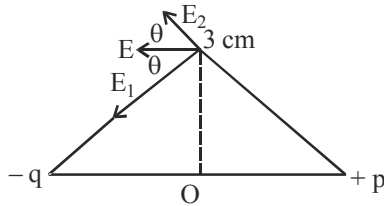

25. (d) Let a total current of $6I$ enter at A. It divides into three equal parts, each of $2I$, along AE, AB and AD. At E, B and D each the current $2I$ divides into two equal parts, each of I , along EF, EH, BF, BC, DH and DC. At F, H and C, the two currents each of I , combine together to give a current of $2I$ at each corner. Thus, at G we get the same current $6I$ as shown in the figure.

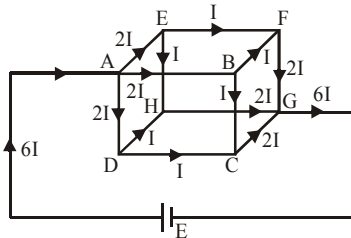

Let r be the value of resistance of each arm of the cube and R be the joint resistance across the corners A and G.

Applying Kirchoff's law along the loop AEFGA, we get

$$2Ir + Ir + 2Ir = E$$

or, $5Ir = E$ (1)

Also, by Ohm's law,

$$6I \times R = E$$

$$\Rightarrow 6IR = 5Ir, \text{ using (1)}$$

$$\text{or, } R = \frac{5}{6}r.$$

Here, $r = 6\Omega$

$$\therefore R = \frac{5}{6} \times 6 = 5\Omega$$

26. (c) Since conductor and semiconductor are connected in parallel hence voltage across them is same. If ammeters show same

reading hence their resistances $R = \frac{V}{I}$ are same. If voltage is increased by small value then following the same relation $V \propto I$ for constant R , both conductor and semiconductor show same current.

27. (d) Time taken by free electrons to cross the conductor

$$t = \frac{\ell}{v_d} \text{ where drift velocity } v_d = \frac{I}{neA}$$

$$\Rightarrow v_d = \frac{1}{8 \times 10^{28} \times 1.6 \times 10^{-19} \times 5 \times 10^{-7}}$$

$$= \frac{10^{-2}}{64} \text{ m/s.}$$

$$\Rightarrow t = \frac{1}{v_d} = \frac{64}{10^{-2}} = 64 \times 10^2 \text{ s} = 6.4 \times 10^3 \text{ sec}$$

28. (b) Temperature coefficient, $\alpha = \frac{R_2 - R_1}{R_1(t_2 - t_1)}$

$$\Rightarrow (t_2 - t_1) = \frac{R_2 - R_1}{\alpha R_1}$$

$$\Rightarrow t_2 - t_1 = \frac{2 - 1}{1 \times 0.00125}$$

$$t_2 = \frac{1}{0.00125} + t_1 = 800 + 300 = 1100\text{K}$$

29. (d) Torque on the coil is $\tau = nIBA \cos\theta$. If coil is set with its plane parallel to direction of magnetic field B , then $\theta = 0^\circ$, $\cos\theta = 1$
 $\Rightarrow \tau = nIBA \cdot 1 = nIBA = \text{maximum}$.
Hence, $I = \text{maximum}$ (as n, B, A are constant)

30. (d) $E = at + \frac{1}{2}bt^2$ is the parabolic equation for thermo emf. The thermoelectric power is

$$S = \frac{dE}{dt}$$

$\Rightarrow S = a + bt$. The graph between $S \left(= \frac{dE}{dt} \right)$ and straight line.

When $t = 0$, $S = a$ (intercept).

At neutral temperature $\frac{dE}{dt} = 0$ and

$t = t_n \Rightarrow 0 = a + bt_n \Rightarrow t_n = \frac{-a}{b}$ and at cold

junction $t_i = 2t_n = \frac{-2a}{b}$

31. (d) Energy of proton = K.E. = $1\text{MeV} = 10^6 \text{ eV}$.

$$\begin{aligned} \text{Frequency } \nu &= \frac{Bq}{2\pi m} \\ &= \frac{6.28 \times 10^{-4} \times 1.6 \times 10^{-19}}{2 \times 3.14 \times 1.7 \times 10^{-27}} \\ &\approx 0.9 \times 10^4 \text{ Hz} \approx 10^4 \text{ Hz} \end{aligned}$$

32. (d) Force on a conductor of length ℓ due to a magnetic field of strength \vec{B} is given by $\vec{F} = I(\vec{\ell} \times \vec{B})$

$$\therefore |\vec{F}| = I\ell B \sin \theta$$

Here, $\theta = 90^\circ$

$$\therefore F = I\ell B = I \times \pi R \times B = \pi RIB$$

Therefore, a force of magnitude (πRIB) will act on each wire. The direction of the forces on each wire will be same. Thus, total force on the wire $AB = \pi RIB + \pi RIB = 2\pi RIB$

33. (d) In first case, the two inductances are in series hence total inductance = $L_0 + L_0 = 2L_0$

In second case, the current is same, but no. of turns has doubled since the sense of turning is same.

$$\text{Thus } L \propto n^2 \Rightarrow L \propto (2n)^2$$

hence inductance $L = 4L_0$

In third case, the sense of turns is opposite. So net inductance cancel each other

$$\therefore L = 0$$

34. (b) At resonance, impedance of circuit is minimum. When impedance of capacitor and inductor is same, $X_L = X_C$ Resonance

$$\text{frequency } \nu = \frac{1}{2\pi\sqrt{LC}}$$

$$\begin{aligned} \nu &= \frac{1}{2\pi\sqrt{5 \times 80 \times 10^{-6}}} = \frac{1}{2\pi\sqrt{400 \times 10^{-6}}} \\ &= \frac{1}{2\pi \times 20 \times 10^{-3}} \\ &= \frac{10^3}{40\pi} = \frac{1000}{40\pi} = \frac{25}{\pi} \end{aligned}$$

35. (b) $M = 5 \text{ H}$, $I = 10 \text{ A}$, $t = 5 \times 10^{-4} \text{ s}$.

Now, emf induced in secondary is

$$e = -M \frac{dI}{dt}, \quad (\text{-ve sign shows direction})$$

$$\Rightarrow e = 5 \times \frac{10}{5 \times 10^{-4}} = 1 \times 10^5 \text{ V}$$

36. (d) Average power of an LCR circuit is $P = E_{\nu} I_{\nu} \cos \phi$. Maximum power is dissipated at resonance when $X_L = X_C$. The resonance frequency is given by

$$\begin{aligned} \nu &= \frac{1}{2\pi\sqrt{LC}} \\ &= \frac{1}{2 \times 3.14 \times \sqrt{25 \times 10^{-3} \times 400 \times 10^{-6}}} \\ &= \frac{1}{2 \times 3.14 \times 5 \times 20 \times 10^{-5} \sqrt{10}} \\ &= \frac{10^5}{3.14 \times 200 \sqrt{10}} \\ &= \frac{10^3}{6.28 \times \sqrt{10}} = \frac{159.2}{3.16} = 50.31 \text{ Hz} \end{aligned}$$

37. (d) Coherent sources should have same frequency and wavelength and constant or zero phase difference. Frequency is same only for wave X_1 and X_4 and phase difference = δ

38. (c) Since position of central maximum is same, hence $a \sin \theta = \lambda$ is same for both wavelengths. i.e, $a = \text{constant}$, $\theta = \text{same}$, $\Rightarrow \lambda$ is same for both waves

$$\Rightarrow \lambda_1 = \lambda_2 \text{ and } \frac{\lambda_1}{\lambda_2} = 1$$

39. (b) For bright fringes, $I_{\max} = (a+b)^2$
For dark fringes, $I_{\min} = (a-b)^2$

$$\text{Now } \frac{I_{\max}}{I_{\min}} = 9 = \frac{(a+b)^2}{(a-b)^2} \Rightarrow \frac{a+b}{a-b} = 3$$

$$\Rightarrow a+b=3(a-b) \Rightarrow a+b=3a-3b \Rightarrow 2a=4b$$

$$\frac{a}{b} = 2 \Rightarrow \frac{a^2}{b^2} = 4.$$

\therefore Ratio of intensities of the two slits,

$$\frac{I_1}{I_2} = \frac{a^2}{b^2} = \frac{4}{1}$$

40. (b) Rising and setting sun appears red because light from the sun travels slightly more distance from the horizon, than when it is overhead. Hence blue light is scattered by dust in the atmosphere because scattering $\propto \frac{1}{\lambda^4}$ and $\lambda_b < \lambda_r$. Red colour is less scattered and reaches us.

PART - II (CHEMISTRY)

41. (b) Rosemund's reaction –

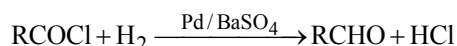

42. (b) $\begin{array}{c} \text{CH}_2\text{CO} \\ | \\ \text{CH}_2\text{CO} \end{array} \text{O} + \text{RMgX} \longrightarrow$

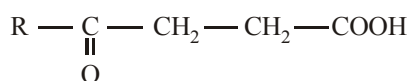
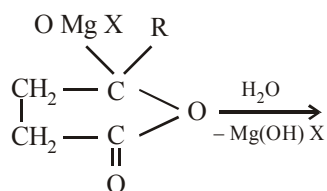

43. (a) (+)-Tartaric acid does not have element of symmetry.

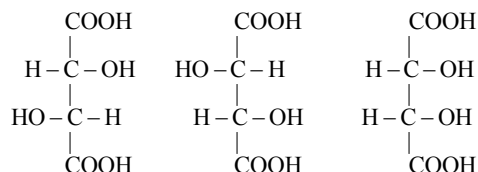

- (+)-Tartaric acid (A) Meso tartaric acid (D)
(Plane of symmetry)

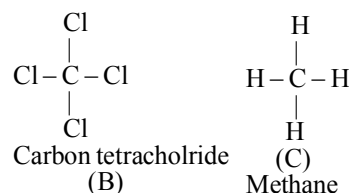

44. (b) Proton donors are acids. Electron withdrawing groups (like halogens) increase the acidity of carboxylic acids. Therefore, HCOOH is weakest acid among the given choices.
45. (a) Toluene is used in the reaction to make both substances (acid and alcohol) miscible.
46. (c) Trans esterification is the process of conversion of one ester to another ester.

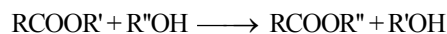

47. (a) It is expected that the basic nature of amines should be in order tertiary > secondary > primary but the observed order in the case of lower members is found to be as secondary > Primary > tertiary. This anomalous behaviour of tertiary amines is due to steric factors i.e crowding of alkyl groups cover nitrogen atom from all sides thus makes the approach and bonding by a proton relatively difficult which results the maximum steric strain in tertiary amines. The electrons are there but the path is blocked, resulting the reduction in basicity. Thus the correct order is $\text{R}_2\text{NH} > \text{RNH}_2 > \text{R}_3\text{N}$.

48. (d) $\text{C}_6\text{H}_5\text{N}_2^+\text{Cl}^- + \text{H}_2\text{O} \xrightarrow{\text{Boiling}} \text{C}_6\text{H}_5\text{OH} + \text{N}_2 + \text{HCl}$
Phenol

49. (a) Carbylamine test is given by aliphatic primary amine.

Aliphatic (or aromatic) 1° amine + CHCl₃ +

KOH → Bad smelling isocyanide.

50. (c) Benzaldehyde reacts with ammonia to form hydrobenzamide.

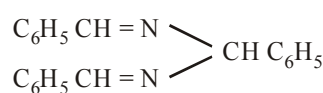
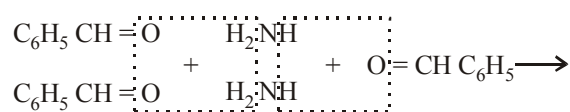

Hydrobenzamide.

Under Pressure ↓ H₂, Ni



51. (b) Hybridisation = $\frac{1}{2}$ [Number of valence electrons of central atom + no. of monovalent atoms attached to it + negative charge if any – positive charge if any]

$$= \frac{1}{2} [6 + 4 + 0 - 0] = 5 = sp^3 d$$

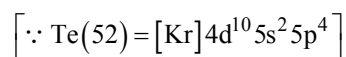

52. (a) The permanganate ion has an intense purple colour. Mn (+ VII) has a d⁰ configuration. So the colour arises from charge transfer and not from d–d spectra. In MnO₄[–] an electron is momentarily changing O^{2–} to O[–] and reducing the oxidation state of the metal from Mn(VII) to Mn(VI). Charge transfer requires that the energy levels on the two different atoms are fairly close.

$$\text{O} = (8) = \begin{array}{l} 2, \\ \text{K} \quad \text{L} \end{array} 6$$

$$\text{Mn} (25) = \begin{array}{l} 2, \\ \text{K} \quad \text{L} \end{array} \begin{array}{l} 8, \\ \text{L} \end{array} \begin{array}{l} 15 \\ \text{M} \end{array}$$

hence the charge transfer occurs from L → M.

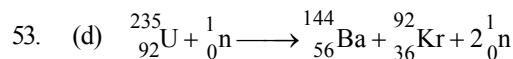

Sum of atomic number of reactants = sum of atomic masses of products.

54. (b) AgCl dissolves in a solution of NH₃ but not in water because Ag⁺ forms soluble complex ion with NH₃.

55. (b) EDTA is hexadentate ligand. 4 oxygen and 2 nitrogen atoms act as donors.

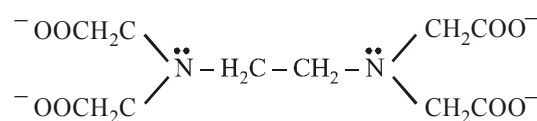

56. (c) A co-ordinate bond is a dative covalent bond in which two atoms form a bond and one of them provides both electrons.

57. (d) [Ni(NH₃)₆]Cl₂ sp³d² hybridisation
2 unpaired electrons
Na₃[FeF₆] sp³d² hybridisation
3 unpaired electrons
[Cr(H₂O)₆]SO₄ d²sp³ hybridisation
3 unpaired electrons
K₄[Fe(CN)₆] d²sp³ hybridisation
No unpaired electrons

Zero magnetic moment means all the electrons paired.

58. (c) The IUPAC name is dichloro triphenyl phosphine nickel (II).

59. (c) (d) In K₄[Fe(CN)₆]Cu is in +1 oxidation state hence has no unpaired electron hence colourless and diamagnetic.

- (b) In (NH₄)₂[TiCl₆]Ti is in +4 oxidation state. hence has no unpaired electron hence colourless and diamagnetic.

- (c) In VOSO₄, V is in +4 oxidation state hence has one unpaired electron, thus it is coloured and paramagnetic.

- (a) In K₂Cr₂O₇, Cr is in +6 oxidation. hence has no unpaired electron and thus it is diamagnetic. Though K₂Cr₂O₇ has no unpaired electron but it is coloured. This is due to charge transfer spectrum.

60. (b) On an X-ray diffraction photograph the intensity of the spots depends on electron density of atoms/ions.

61. (a) In Frankel's defect an ion leaves its regular site and occupies a position in the space between the lattice sites.

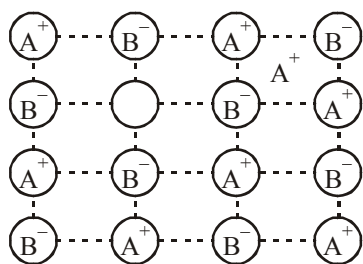

62. (b) 8 : 8 type of packing is present in CsCl.
6 : 6 type of packing is present in NaCl and KCl.

63. (d) When solid melts S increases. because when solid changes into liquid randomness increases.

64. (d) Gibbs Helmholtz Equation—
 $\Delta G = \Delta H - T\Delta S$ (1)
differentiate this equation w.r.t. temperature at constant pressure

$$\left(\frac{\partial \Delta G}{\partial T}\right)_P = \left(\frac{\partial G_y}{\partial T}\right)_P - \left(\frac{\partial G_x}{\partial T}\right)_P \quad \dots(2)$$

$$= -S_y - (-S_x)$$

$$= -(S_y - S_x) = -\Delta S \quad \dots(3)$$

where ΔS change in entropy
on combining equation (1) & (3) we get

$$\Delta G = \Delta H + T \left(\frac{\partial(\Delta G)}{\partial T}\right)_P \quad \dots(4)$$

Equation (4) is an alternative form of Gibbs Helmholtz equation

Dividing equ. (4) by T^2 , we get

$$\frac{\Delta G}{T^2} = \frac{\Delta H}{T^2} + \frac{1}{T} \left[\frac{\partial(\Delta G)}{\partial T}\right]_P$$

on rearrangement, we get

$$\left[\frac{\partial(\Delta G)}{\partial T}\right]_P = -\frac{\Delta H}{T^2}$$

$$\therefore \Delta H = -T^2 \left[\frac{\partial(\Delta G)}{\partial T}\right]_P$$

65. (a) Since $\Delta G = \Delta A + P \cdot \Delta V$

For a spontaneous process ΔG should be negative which is possible only if

$$\Delta A + P \cdot \Delta V \text{ or } \Delta A + W < 0.$$

66. (c) We have to find

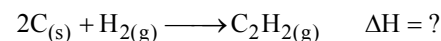

This is the equation for formation of acetylene Given

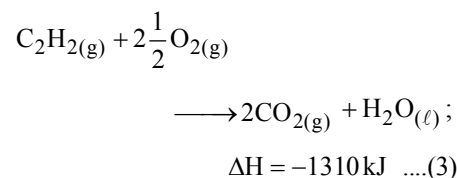
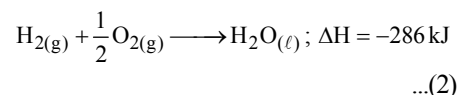
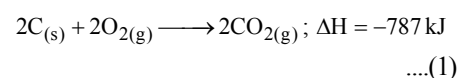

Add eq.(1) and (2)

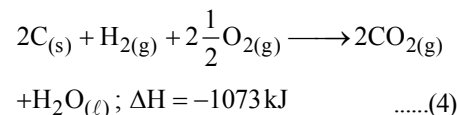

Subtract eq. (3) from eq. (4) we get

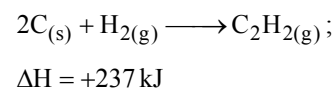

67. (b) Endothermic reactions are favoured at high temperature. Therefore, increasing the temperature will shift equilibrium to the right.

68. (a) $\ln \frac{k_2}{k_1} = \frac{E_a}{2.303R} \left[\frac{1}{T_1} - \frac{1}{T_2} \right]$

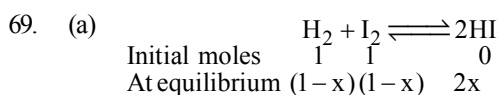

$$K_c = \frac{[HI]^2}{[H_2][I_2]} = \frac{(2x)^2}{(1-x)^2}$$

Given $x = 80\% = 0.80$

$$\therefore K_c = \frac{(2 \times 0.80)^2}{(1-0.80)^2} = 64$$

70. (d) The equilibrium constant K_p will change with temperature for the reaction

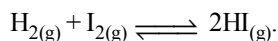

Catalyst does not alter the state of equilibrium.

Equilibrium constant depends only upon temperature. The relation of k with temp can be shown as

$$\log \frac{k_2}{k_1} = \frac{\Delta H}{2.303R} \left[\frac{1}{T_1} - \frac{1}{T_2} \right]$$

71. (d) Eq. mass of $\text{Ca}^{++} = \frac{\text{Mol. mass}}{2} = \frac{40}{2} = 20$

$$Z = \frac{\text{Eq. mass of water}}{96500} = \frac{20}{96500}$$

Given $w = 60 \text{ g}$, $i = 5 \text{ amp}$.

$w = zit$

$$\text{or } 60 = \frac{20}{96500} \times 5 \times t$$

$$\therefore t = \frac{96500 \times 60}{20 \times 5} = 57900 \text{ sec} = 16 \text{ h.}$$

72. (b) According to Debye – Huckel – Onsagar equation $\Lambda_m = \Lambda_m^\circ - (A + B \Lambda_m^\circ) \sqrt{C}$ where A and B are the Debye – Huckel constants. If we plot a graph between molar conductance (Λ_m) against the square roots of the concentration (\sqrt{C}) a straight line is obtained

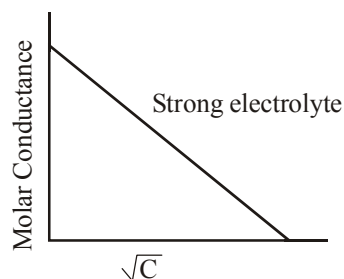

73. (c) Molar conductance of CaCl_2
 $= \text{Molar conductance of } \text{Ca}^{2++} + 2 \times (\text{molar conductance of } \text{Cl}^-)$
 $= 118.88 \times 10^{-4} + 2(77.33 \times 10^{-4})$
 $= 273.54 \times 10^{-4} \text{ m}^2 \text{ mho mol}^{-1}$

74. (a) Lower the value of reduction potential, greater will be the reducing power of element.

Since Zn has lowest reduction potential hence Zn is the strongest reducing agent.

75. (a) The epoxide ring consists of three membered ring with two carbon atoms and one oxygen.

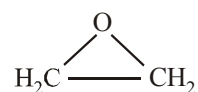

76. (c) Grignard reagent is a sigma bonded organometallic compound in which Mg is bonded with one alkyl and one halogen group. This can be prepared as

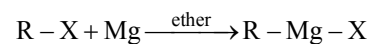

77. (a,c) Presence of electron attracting group like $-\text{NO}_2$, $-\text{Cl}$ increases the acidity of phenol as it enables the ring to draw more electrons from the phenoxy oxygen and thus releasing easily the proton. Presence of electron releasing group e.g. $-\text{OCH}_3$ on benzene ring decreases the acidity of phenol as it strengthens the negative charge on phenoxy oxygen and thus proton release becomes difficult.

Further phenols are much more acidic than alcohols. The acidic nature of phenol is due to the formation of stable phenoxide ion in solution.

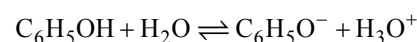

No resonance is possible in alkoxide ions (RO^-) derived from alcohols. The negative charge is localized on oxygen atom. Thus alcohols are not acidic.

78. (b) Aldol condensation is given by aldehydes which have α -H atoms. So acetaldehyde gives this reaction.

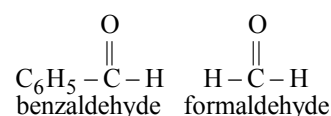
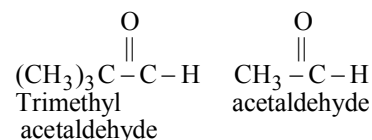

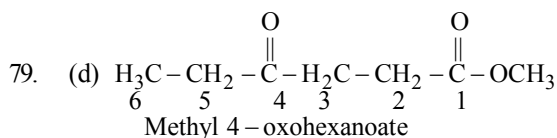

80. (b) It is cycloaddition reaction between a conjugated diene and substituted alkene or α , β unsaturated carboxyl compound.

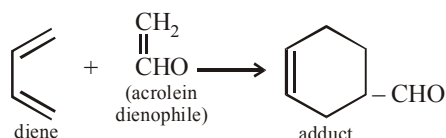

PART - III (MATHEMATICS)

81. (c) Since \vec{a} and \vec{b} are coplanar, therefore $\vec{a} \times \vec{b}$ is a vector perpendicular to the plane containing \vec{a} and \vec{b} . Similarly $\vec{c} \times \vec{d}$ is a vector perpendicular to the plane containing \vec{c} and \vec{d} . Thus, the two planes will be parallel if their normals i.e. $\vec{a} \times \vec{b}$ and $\vec{c} \times \vec{d}$ are parallel.

$$\Rightarrow (\vec{a} \times \vec{b}) \times (\vec{c} \times \vec{d}) = 0$$

82. (d) Given : diagonals $\vec{d}_1 = 3\hat{i} + \hat{j} - 2\hat{k}$ and $\vec{d}_2 = \hat{i} - 3\hat{j} + 4\hat{k}$

$$\therefore \text{Area of a parallelogram} = \frac{1}{2} |\vec{d}_1 \times \vec{d}_2|$$

$$\text{Now, } \vec{d}_1 \times \vec{d}_2 = \begin{vmatrix} \hat{i} & \hat{j} & \hat{k} \\ 3 & 1 & -2 \\ 1 & -3 & 4 \end{vmatrix}$$

$$= \hat{i}(4-6) - \hat{j}(12+2) + \hat{k}(-9-1)$$

$$\Rightarrow \vec{d}_1 \times \vec{d}_2 = -2\hat{i} - 14\hat{j} - 10\hat{k}$$

$$\therefore |\vec{d}_1 \times \vec{d}_2| = \sqrt{(-2)^2 + (-14)^2 + (-10)^2}$$

$$= \sqrt{4+196+100} = \sqrt{300} = 2\sqrt{75}$$

$$\therefore \text{Area of parallelogram} = \frac{1}{2} |\vec{d}_1 \times \vec{d}_2|$$

$$= \frac{1}{2} \times 2\sqrt{75} = \sqrt{75} \text{ square units}$$

83. (d) Given : $\cos x + \cos^2 x = 1$
 $\Rightarrow \cos x = 1 - \cos^2 x \Rightarrow \cos x = \sin^2 x$
 $\Rightarrow \cos^2 x = \sin^4 x \Rightarrow 1 - \sin^2 x = \sin^4 x$
 $\Rightarrow \sin^4 x + \sin^2 x = 1$

cubic both sides, we have

$$\sin^{12} x + \sin^6 x + 3 \sin^6 x (\sin^4 x + \sin^2 x) = 1$$

$$\Rightarrow \sin^{12} x + \sin^6 x + 3 \sin^{10} x + 3 \sin^8 x = 1$$

$$\Rightarrow \sin^{12} x + 3 \sin^{10} x + 3 \sin^8 x + \sin^6 x - 1 = 0$$

84. (c) $(\cos \alpha + i \sin \alpha)^{3/5} = (\cos 3\alpha + i \sin 3\alpha)^{1/5}$
 $= [\cos (2k\pi + 3\alpha) + i \sin (2k\pi + 3\alpha)]^{1/5}$
 $= \left[\cos \left(\frac{2k\pi + 3\alpha}{5} \right) + i \sin \left(\frac{2k\pi + 3\alpha}{5} \right) \right],$

where $k=0, 1, 2, 3, 4$

Product of all values.

$$= \left(\cos \frac{3\alpha}{5} + i \sin \frac{3\alpha}{5} \right) \cdot \left(\cos \left(\frac{2\pi + 3\alpha}{5} \right) \right.$$

$$\left. + i \sin \left(\frac{2\pi + 3\alpha}{5} \right) \right) \cdot \left(\cos \frac{4\pi + 3\alpha}{5} + i \sin \right.$$

$$\left. \frac{4\pi + 3\alpha}{5} \right) \cdot \left(\cos \frac{6\pi + 3\alpha}{5} + i \sin \frac{6\pi + 3\alpha}{5} \right) \cdot$$

$$\left(\cos \left(\frac{8\pi + 3\alpha}{5} \right) + i \sin \left(\frac{8\pi + 3\alpha}{5} \right) \right)$$

$$= \cos \left[\frac{3\alpha}{5} + \frac{2\pi + 3\alpha}{5} + \frac{4\pi + 3\alpha}{5} + \frac{6\pi + 3\alpha}{5} + \right.$$

$$\left. \frac{8\pi + 3\alpha}{5} \right] + i \sin \left[\frac{3\alpha}{5} + \frac{2\pi + 3\alpha}{5} + \frac{4\pi + 3\alpha}{5} + \frac{6\pi + 3\alpha}{5} + \frac{8\pi + 3\alpha}{5} \right]$$

$$= \cos \left[\frac{5}{2} \left(2 \cdot \frac{3\alpha}{5} + (5-1) \cdot \left(\frac{2\pi}{5} \right) \right) \right]$$

$$+ i \sin \left[\frac{5}{2} \left(2 \cdot \frac{3\alpha}{5} + (5-1) \cdot \left(\frac{2\pi}{5} \right) \right) \right]$$

$$= \cos \left[\frac{5}{2} \left(\frac{6\alpha}{5} + \left(\frac{8\pi}{5} \right) \right) \right] +$$

$$i \sin \left[\frac{5}{2} \left(\frac{6\alpha}{5} + \frac{8\pi}{5} \right) \right]$$

$$= \cos (3\alpha + 4\pi) + i \sin (3\alpha + 4\pi)$$

$$= \cos (4\pi + 3\alpha) + i \sin (4\pi + 3\alpha)$$

$$= \cos 3\alpha + i \sin 3\alpha$$

85. (d) $\frac{(1+i)^2}{i(2i-1)} = \frac{1+i^2+2i}{2i^2-i}$

$$\Rightarrow \frac{1-1+2i}{-2-i} = -\frac{2i}{2+i} \times \frac{(2-i)}{(2-i)} = \frac{-4i+2i^2}{4-i^2}$$

[$\because i^2 = -1$]

$$= \frac{-4i-2}{4+1} = \frac{-2-4i}{5} \Rightarrow \frac{-2}{5} - \frac{4i}{5}$$

\therefore The imaginary part = $-\frac{4}{5}$

86. (a) Given $\sin^{-1}x + \sin^{-1}y = \frac{\pi}{2}$ (i)

we know that $\sin^{-1}x + \cos^{-1}x = \frac{\pi}{2}$

$\Rightarrow \sin^{-1}x = \frac{\pi}{2} - \cos^{-1}x$
 \therefore Equation (1) becomes.

$$\frac{\pi}{2} - \cos^{-1}x + \frac{\pi}{2} - \cos^{-1}y = \frac{\pi}{2}$$

$$\Rightarrow \cos^{-1}x + \cos^{-1}y = \frac{\pi}{2}$$

87. (c) Equation of ellipse $\frac{x^2}{b^2} + \frac{y^2}{a^2} = 1$, where

$a > b$.

Given, $\frac{x^2}{16} + \frac{y^2}{75} = 1 \Rightarrow b=4, a=5$

But $e = \sqrt{1 - \frac{b^2}{a^2}} = \sqrt{1 - \frac{16}{25}}$

$$\Rightarrow e = \frac{3}{5}$$

\therefore equation of directrix $y = \pm \frac{a}{e}$

$$\therefore y = \pm \frac{5}{3/5} \Rightarrow 3y = \pm 25$$

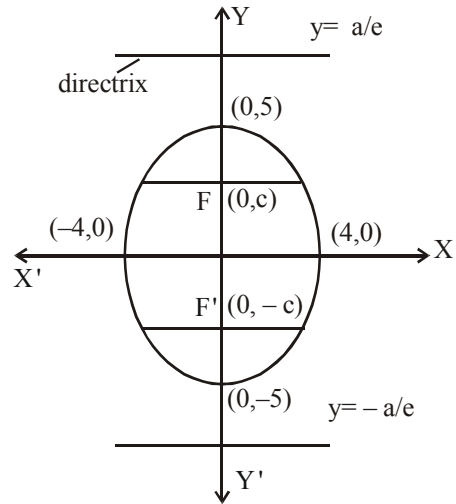

88. (a) Since the normal at $(ap^2, 2ap)$ on $y^2 = 4ax$ meets the curve again at $(aq^2, 2aq)$, therefore $px + y = 2ap + ap^3$ passes through $(aq^2, 2aq)$

$$\Rightarrow paq^2 + 2aq = 2ap + ap^3$$

$$\Rightarrow p(q^2 - p^2) = 2(p - q)$$

$$\Rightarrow p(q + p) = -2$$

$$\Rightarrow p^2 + pq + 2 = 0$$

89. (d) Given : equation of line, $x - 3y = 1$ (1)
and hyperbola $x^2 - 4y^2 = 1$ (2)
putting $x = 1 + 3y$ in equation (2), we get
 $(1 + 3y)^2 - 4y^2 = 1 \Rightarrow 1 + 9y^2 + 6y - 4y^2 = 1$
 $\Rightarrow 5y^2 + 6y = 0 \Rightarrow y(5y + 6) = 0$

$$\Rightarrow y = 0 \text{ or } y = -\frac{6}{5}$$

$$\therefore x = 1 \text{ for } y = 0 \text{ \& } x = 1 - \frac{18}{5} = \frac{-13}{5}$$

for $y = -6/5$

\therefore the line (1) cuts the hyperbola (2) in at most two point.

\therefore co-ordinates of points are $P(1, 0)$ &

$$Q\left(-\frac{13}{5}, -\frac{6}{5}\right)$$

$$\therefore PQ = \sqrt{\left(1 + \frac{13}{5}\right)^2 + \left(0 + \frac{6}{5}\right)^2}$$

$$= \sqrt{\left(\frac{18}{5}\right)^2 + \frac{36}{25}} = \sqrt{\frac{324+36}{25}} = \sqrt{\frac{360}{25}}$$

$$\therefore \text{length of straight line PQ} = \frac{6\sqrt{10}}{5} \text{ units.}$$

90. (c) Given $x = t^2 + 2t - 1$ & $y = 3t + 5$
 $\Rightarrow x = t^2 + 2t + 1 - 2$ & $y = 3t + 3 + 2$
 $\Rightarrow x = (t+1)^2 - 2$ & $y = 3(t+1) + 2$ (2)
 $\Rightarrow (t+1) = \sqrt{x+2}$ (1)

\therefore Equation (2) becomes [using equation (1)]

$$y = 3\sqrt{x+2} + 2$$

$$\Rightarrow y - 2 = 3\sqrt{x+2}$$

squaring both sides, we get

$$(y-2)^2 = 9(x+2)$$

$$\Rightarrow Y^2 = 9X \text{ where } Y = y - 2 \text{ & } X = x + 2$$

This equation represents a parabola

91. (c) Slope of the normal at (3,4) is the value of

$$-\frac{1}{f'(x)} \text{ at } x = 3 \text{ or } -\frac{1}{f'(3)} = \tan \frac{3\pi}{4} = -1$$

$$\Rightarrow f'(3) = 1$$

92. (c) Given : $f(x) = x^2 e^{-2x}$, $x > 0$
 $f'(x) = x^2 \cdot e^{-2x}(-2) + e^{-2x} \cdot 2x$
 put $f'(x) = 0 \Rightarrow 2e^{-2x} \cdot x(-x+1) = 0$
 $\Rightarrow x = 1$ or $x = 0$
 $f''(x) = (-4x^2 - 6x + 1)e^{-2x}$
 $f''(1) = -9e^{-2} < 0$
 $f''(0) = e^{-2} > 0$
 \therefore value of $f(x)$ is maximum at $x = 1$

$$\therefore f(x) = x^2 \cdot e^{-2x} \Rightarrow f(1) = e^{-2} = \frac{1}{e^2}$$

93. (d) Given : $(x+y) \sin U = x^2 y^2$

$$\Rightarrow \sin U = \frac{x^2 y^2}{x+y} = v \text{ (let)}$$

$$\text{Here } n = 2 - 1 = 1$$

$$\text{Euler's theorem } x \cdot \frac{\partial v}{\partial x} + y \cdot \frac{\partial v}{\partial y} = nv$$

$$\therefore x \frac{\partial \sin U}{\partial x} + y \frac{\partial \sin U}{\partial y} = \sin U$$

$$\Rightarrow x \cdot \cos U \frac{\partial U}{\partial x} + y \cdot \cos U \frac{\partial U}{\partial y} = \sin U$$

$$\Rightarrow x \frac{\partial U}{\partial x} + y \frac{\partial U}{\partial y} = \frac{\sin U}{\cos U} = \tan U$$

$$\Rightarrow x \frac{\partial U}{\partial x} + y \frac{\partial U}{\partial y} = \tan U$$

94. (c) Equation of the given curve in parametric form,

$$x = t^2 + 1 \text{ and } y = t^2 - t - 6$$

Y-coordinate of the point, where the given curve meets X-axis is 0.

$$\text{When } y = 0, \text{ then } t^2 - t - 6 = 0$$

$$\Rightarrow t^2 - 3t + 2t - 6 = 0$$

$$\Rightarrow t(t-3) + 2(t-3) = 0$$

$$\Rightarrow (t-3)(t+2) = 0$$

$$\Rightarrow t = 3 \text{ or } -2$$

$$\text{when } t = 3, \text{ then } x = 10$$

$$\text{when } t = -2, \text{ then } x = 5$$

Hence, the points where the curve meets the X-axis are (10, 0) and (5, 0).

$$\text{Now, } \frac{dy}{dx} = \frac{\frac{dy}{dt}}{\frac{dx}{dt}} = \frac{2t-1}{2t}$$

Slope of the tangent at point (10, 0)

$$m_1 = \left. \frac{dy}{dx} \right|_{x=10} = \left. \frac{dy}{dx} \right|_{t=3} = \frac{5}{6}$$

Slope of the tangent at point (5, 0),

$$m_2 = \left. \frac{dy}{dx} \right|_{x=5} = \left. \frac{dy}{dx} \right|_{t=-2} = \frac{-5}{-4} = \frac{5}{4}$$

If θ be the angle between two tangents, then

$$\tan \theta = \left| \frac{m_2 - m_1}{1 + m_1 m_2} \right| = \left| \frac{\frac{5}{4} - \frac{5}{6}}{1 + \frac{5}{6} \cdot \frac{5}{4}} \right|$$

$$= \left| \frac{\frac{15-10}{24}}{\frac{24+25}{24}} \right| = \left| \frac{\frac{5}{24}}{\frac{49}{24}} \right| = \left| \frac{5}{49} \right|$$

$$\Rightarrow \tan \theta = \pm \frac{10}{49}$$

$$\therefore \theta = \tan^{-1} \left(\pm \frac{10}{49} \right) = \pm \tan^{-1} \left(\frac{10}{49} \right)$$

$$\begin{aligned}
 95. \quad (b) \quad \int_1^4 |x-3| dx &= \int_1^3 -(x-3) dx + \int_3^4 (x-3) dx \\
 &= -\left[\frac{x^2}{2} - 3x\right]_1^3 + \left[\frac{x^2}{2} - 3x\right]_3^4 \\
 &= -\frac{1}{2}[3^2 - 1^2] + 3[3-1] + \frac{1}{2}[4^2 - 3^2] - 3[4-3] \\
 &= -\frac{1}{2}(8) + 3(2) + \frac{1}{2}(7) - 3(1) \\
 &= -4 + 6 + \frac{7}{2} - 3 = \frac{5}{2}
 \end{aligned}$$

$$96. \quad (b) \quad \text{Required area} = \int_0^2 (y_2 - y_1) dx$$

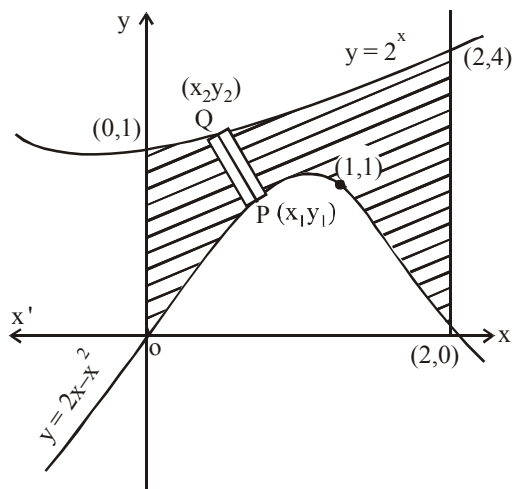

$$\begin{aligned}
 &= \int_0^2 (2^x - 2x + x^2) dx \\
 &= \left[\frac{2^x}{\log 2} - x^2 + \frac{x^3}{3} \right]_0^2 \\
 &= \frac{4}{\log 2} - 4 + \frac{8}{3} - \frac{1}{\log 2} = \frac{3}{\log 2} - \frac{4}{3}
 \end{aligned}$$

$$97. \quad (d) \quad \text{Let } I = \int_0^{\infty} \frac{dx}{(a^2 + x^2)^7}$$

$$\text{Put } x = a \tan \theta \Rightarrow dx = a \sec^2 \theta d\theta$$

$$\text{limit at } x = 0 \Rightarrow \theta = 0 \text{ \& } x = \infty \Rightarrow \theta = \frac{\pi}{2}$$

$$\therefore I = \int_0^{\frac{\pi}{2}} \frac{a \sec^2 \theta}{a^{14} (1 + \tan^2 \theta)^7} d\theta$$

$$= \frac{1}{a^{13}} \int_0^{\frac{\pi}{2}} \frac{1}{\sec^{12} \theta} d\theta = \frac{1}{a^{13}} \int_0^{\frac{\pi}{2}} \cos^{12} \theta d\theta$$

But

$$\int_0^{\frac{\pi}{2}} \sin^{2m-1} \theta \cdot \cos^{2n-1} \theta \cdot d\theta = \frac{1}{2} B(m, n)$$

$$\& B(m, n) = \frac{\sqrt{m} \sqrt{n}}{\sqrt{m+n}} \& \left[\frac{1}{2} \right] = \sqrt{\pi}$$

$$\therefore I = \frac{1}{a^{13}} \int_0^{\frac{\pi}{2}} \sin^0 \theta \cdot \cos^{12} \theta d\theta$$

$$\therefore m = \frac{1}{2}, \quad n = \frac{13}{2}$$

$$\therefore I = \frac{1}{2a^{13}} \frac{\left[\frac{1}{2} \right] \left[\frac{13}{2} \right]}{\left[\frac{1}{2} + \frac{13}{2} \right]}$$

$$= \frac{1}{2a^{13}} \cdot \frac{\sqrt{\pi} \cdot \frac{11}{2} \cdot \frac{9}{2} \cdot \frac{7}{2} \cdot \frac{5}{2} \cdot \frac{3}{2} \cdot \frac{1}{2} \cdot \sqrt{\pi}}{6.5.4.3.2.1}$$

$$= \left(\frac{231}{2048} \cdot \frac{1}{a^{13}} \right) \pi$$

98. (c) Let $I = \int e^x \frac{(1-x)^2}{(1+x^2)^2} dx$

$$\Rightarrow I = \int e^x \frac{1+x^2-2x}{(1+x^2)^2} dx$$

$$= \int e^x \left[\frac{1+x^2}{(1+x^2)^2} - \frac{2x}{(1+x^2)^2} \right] dx$$

$$\Rightarrow I = \int e^x \frac{1}{(1+x^2)} dx - 2 \int e^x \cdot \frac{x}{(1+x^2)^2} dx$$

$$\Rightarrow I = \frac{1}{(1+x^2)} e^x - \int e^x \cdot [-(1+x^2)^{-2}] 2x dx$$

$$- 2 \int \frac{e^x x}{(1+x^2)^2} dx$$

$$\Rightarrow I = \frac{e^x}{1+x^2} + 2 \int \frac{e^x x}{(1+x^2)^2} dx$$

$$- 2 \int \frac{e^x x}{(1+x^2)^2} dx$$

$$\Rightarrow I = \frac{e^x}{1+x^2} + C$$

99. (c) Given : $x \sin\left(\frac{y}{x}\right) dy = \left[y \sin\left(\frac{y}{x}\right) - x \right] dx$

$$\Rightarrow \frac{dy}{dx} = \frac{y \sin\left(\frac{y}{x}\right) - x}{x \sin\left(\frac{y}{x}\right)}$$

Put $\frac{y}{x} = z \Rightarrow \frac{dy}{dx} = z + x \cdot \frac{dz}{dx}$

$$\therefore x \cdot \frac{dz}{dx} + z = \frac{zx \sin z - x}{x \sin z} = z - \operatorname{cosec} z$$

$$\Rightarrow x \frac{dz}{dx} = -\operatorname{cosec} z \Rightarrow -\sin z dz = \frac{dx}{x}$$

$$\Rightarrow \cos z = \log x + c$$

$$\Rightarrow \cos\left(\frac{y}{x}\right) = \log x + c$$

But $y(1) = \frac{\pi}{2} \Rightarrow x = 1, y = \frac{\pi}{2}$

$$\therefore \cos \frac{\pi}{2} = \log(1) + c \Rightarrow c = 0$$

$$\therefore \cos\left(\frac{y}{x}\right) = \log x$$

100. (c) The equation of the family of circles of radius r is

$$(x-a)^2 + (y-b)^2 = r^2 \quad \dots(1)$$

Where a & b are arbitrary constants.

Since equation (1) contains two arbitrary constants, we differentiate it two times w.r.t x & the differential equation will be of second order.

Differentiating (1) w.r.t x , we get

$$2(x-a) + 2(y-b) \frac{dy}{dx} = 0$$

$$\Rightarrow (x-a) + (y-b) \frac{dy}{dx} = 0 \quad \dots(2)$$

Differentiating (2) w.r.t x , we get

$$1 + (y-b) \frac{d^2y}{dx^2} + \left(\frac{dy}{dx}\right)^2 = 0 \quad \dots(3)$$

$$\Rightarrow (y-b) = -\frac{1 + \left(\frac{dy}{dx}\right)^2}{\frac{d^2y}{dx^2}} \quad \dots(4)$$

On putting the value of $(y-b)$ in equation (2), we get

$$x-a = \frac{\left[1 + \left(\frac{dy}{dx}\right)^2\right] \frac{dy}{dx}}{\frac{d^2y}{dx^2}} \quad \dots(5)$$

Substituting the values of $(x-a)$ & $(y-b)$ in (1), we get

$$\frac{\left[1 + \left(\frac{dy}{dx}\right)^2\right]^2 \left(\frac{dy}{dx}\right)^2}{\left(\frac{d^2y}{dx^2}\right)^2} + \frac{\left[1 + \left(\frac{dy}{dx}\right)^2\right]^2}{\left(\frac{d^2y}{dx^2}\right)^2} = r^2$$

$$\Rightarrow \left[1 + \left(\frac{dy}{dx}\right)^2\right]^3 = r^2 \left(\frac{d^2y}{dx^2}\right)^2$$

101. (c) Given : $\frac{d^2y}{dx^2} + 2\frac{dy}{dx} + y = 2e^{3x}$

The auxiliary equation is

$$D^2 + 2D + 1 = 0 \text{ or } m^2 + 2m + 1 = 0$$

$$\Rightarrow (m+1)(m+1) = 0 \Rightarrow m = -1, -1$$

i.e., repeated roots

$$\therefore \text{Complementary function} = (c_1 + c_2x)e^{-x}$$

Now Particular Integral (P.I.)

$$= \frac{1}{D^2 + 2D + 1} \cdot 2e^{3x} \quad [D=3]$$

$$\text{P.I.} = \frac{1}{3^2 + 2 \cdot 3 + 1} \cdot 2e^{3x} = \frac{2e^{3x}}{16} = \frac{e^{3x}}{8}$$

Solution $y = C.F. + P.I.$

$$\Rightarrow y = (c_1 + c_2x)e^{-x} + \frac{e^{3x}}{8}$$

102. (c) Given $ydx + (x - y^3)dy = 0$

$$\Rightarrow y \frac{dx}{dy} + x - y^3 = 0 \Rightarrow \frac{dx}{dy} + \frac{1}{y}x = y^2$$

compare this equation to general equation

$$\text{i.e. } \frac{dx}{dy} + Px = Q \Rightarrow P = \frac{1}{y}, Q = y^2$$

$$\therefore \text{I.f.} = e^{\int Pdy} = e^{\int \frac{1}{y} dy} = e^{\log y} = y$$

$$x \times \text{I.f.} = \int Q \times \text{I.f.} dy + C_1$$

$$\Rightarrow x \cdot y = \int y^2 \cdot y dy + C_1 \Rightarrow xy = \frac{y^4}{4} + C_1$$

$$\Rightarrow 4xy = y^4 + 4C_1$$

$$\Rightarrow y^4 = 4xy - 4C_1 \Rightarrow y^4 = 4xy + C,$$

where $C = -4C_1$

103. (b) Given, $x_1x_2x_3x_4x_5 = 1050$

$$\Rightarrow x_1x_2x_3x_4x_5 = 2 \times 3 \times 5^2 \times 7$$

Each of 2, 3 or 7 can take 5 places and 5^2 can be disposed in 15 ways.

Hence, number of positive integral solution = $5^3 \times 15 = 1875$

104. (d) Number of onto functions: If A & B are two sets having m & n elements respectively such that $1 \leq n \leq m$ then number of onto functions from A to B is

$$\sum_{r=1}^n (-1)^{n-r} \cdot {}^n C_r r^n$$

Given $A = \{1, 2, 3, \dots, n\}$ & $B = \{a, b, c\}$

\therefore Number of onto functions

$$= \sum_{r=1}^3 (-1)^{3-r} \cdot {}^3 C_r (r)^n$$

$$= (-1)^{3-1} {}^3 C_1 (1)^n + (-1)^{3-2} {}^3 C_2 (2)^n + {}^3 C_3 (3)^n (-1)^{3-3}$$

$$= {}^3 C_1 - {}^3 C_2 2^n + {}^3 C_3 3^n$$

$$= \frac{3!}{2!1!} - \frac{3!}{2!1!} 2^n + \frac{3!}{3!0!} 3^n$$

$$= 3 - 3 \cdot 2^n + 3^n$$

$$= 3^n - 3(2^n - 1)$$

105. (b) Let there are n persons in the room. The total number of hand shakes is same as the number of ways of selecting 2 out of n.

$$\therefore {}^n C_2 = 66 \Rightarrow \frac{n(n-1)}{2!} = 66$$

$$\Rightarrow n^2 - n - 132 = 0$$

$$\Rightarrow (n-12)(n+11) = 0 \Rightarrow n = 12$$

106. (a) We know that, let (G, 0) be a group & e be the identity then

$$(a * a)^{-1} = a^{-1} \circ a^{-1} = (a^{-1})^{-1} = a.$$

107. (d) No. of tickets = 9

No. of odd numbered tickets = 5

No. of even numbered tickets = 4

Required probability = P {odd, even, odd} + P (even, odd, even)

$$= \frac{{}^5 C_1}{{}^9 C_1} \times \frac{{}^4 C_1}{{}^8 C_1} \times \frac{{}^4 C_1}{{}^7 C_1} + \frac{{}^4 C_1}{{}^9 C_1} \times \frac{{}^5 C_1}{{}^8 C_1} \times \frac{{}^3 C_1}{{}^7 C_1}$$

$$= \frac{5}{9} \times \frac{4}{8} \times \frac{4}{7} + \frac{4}{9} \times \frac{5}{8} \times \frac{3}{7} = \frac{5}{18}$$

108. (a) Given

$$P(A) = \frac{1}{12}, P(B) = \frac{5}{12}, P(B/A) = \frac{1}{15}$$

$$\text{We know that } P(B/A) = \frac{P(A \cap B)}{P(A)}$$

$$\Rightarrow \frac{1}{15} = \frac{P(A \cap B)}{1/12}$$

$$\Rightarrow P(A \cap B) = \frac{1}{15 \times 12} = \frac{1}{180}$$

But,

$$P(A \cup B) = P(A) + P(B) - P(A \cap B)$$

$$\Rightarrow P(A \cup B) = \frac{1}{12} + \frac{5}{12} - \frac{1}{180} = \frac{89}{180}$$

109. (a) $\int_{1.5}^2 f(x) dx$, where $f(x) = \frac{x}{2}$

$$\int_{1.5}^2 \frac{x}{2} dx = \frac{1}{2} \int_{1.5}^2 x dx = \frac{1}{2} \left[\frac{x^2}{2} \right]_{1.5}^2$$

$$= \frac{1}{4} [4 - 2.25] = \frac{1}{4} \times [1.75] = \frac{175}{400} = \frac{7}{16}$$

110. (b) If $2P(X=0) + P(X=2) = 2P(X=1)$
Let probability distribution of X be given by

$$P(X=r) = \frac{m^r \cdot e^{-m}}{r!} \text{ where } r=0, 1, 2, \dots$$

$$\therefore 2 \left[\frac{m^0 e^{-m}}{0!} \right] + \left[\frac{m^2 \cdot e^{-m}}{2!} \right] = 2 \left[\frac{m \cdot e^{-m}}{1!} \right]$$

$$\Rightarrow 2 + \frac{m^2}{2} = 2m \Rightarrow m^2 - 4m + 4 = 0$$

$$\Rightarrow (m-2)^2 = 0 \Rightarrow m = 2$$

111. (c) $A(\theta) = \begin{bmatrix} 1 & \tan \theta \\ -\tan \theta & 1 \end{bmatrix}$ & $AB = I$

$$B = IA^{-1}, A_{11} = 1, A_{12} = +\tan \theta,$$

$$A_{21} = -\tan \theta, A_{22} = 1$$

$$\therefore |A| = \begin{vmatrix} 1 & \tan \theta \\ -\tan \theta & 1 \end{vmatrix} = 1 + \tan^2 \theta = \sec^2 \theta$$

$$\Rightarrow A^{-1} = \frac{1}{\sec^2 \theta} \begin{bmatrix} 1 & -\tan \theta \\ \tan \theta & 1 \end{bmatrix}$$

$$B = \frac{1}{\sec^2 \theta} \begin{bmatrix} 1 & 0 \\ 0 & 1 \end{bmatrix} \begin{bmatrix} 1 & -\tan \theta \\ \tan \theta & 1 \end{bmatrix}$$

$$B = \frac{1}{\sec^2 \theta} \begin{bmatrix} 1 & -\tan \theta \\ \tan \theta & 1 \end{bmatrix}$$

$$B = \frac{1}{\sec^2 \theta} \cdot A(-\theta)$$

$$\Rightarrow (\sec^2 \theta) \cdot B = A(-\theta)$$

$$\Rightarrow (\cos^2 \theta)^{-1} \cdot B = A(-\theta)$$

112. (b) Given: $\begin{vmatrix} 2x+1 & 4 & 8 \\ 2 & 2x & 2 \\ 7 & 6 & 2x \end{vmatrix} = 0$

$$\therefore (2x+1)(4x^2-12) - 4(4x-14) + 8(12-14x) = 0$$

$$\Rightarrow 8x^3 - 24x + 4x^2 - 12 - 16x + 56 + 96 - 112x = 0$$

$$\Rightarrow 8x^3 + 4x^2 - 152x + 140 = 0$$

(x+5) is a factor of above equation

$$\therefore 8x^3 + 40x^2 - 36x^2 - 180x + 28x + 140 = 0$$

$$\Rightarrow 8x^2(x+5) - 36x(x+5) + 28(x+5) = 0$$

$$\Rightarrow (x+5)(8x^2 - 36x + 28) = 0$$

$$\Rightarrow (x+5)4(2x^2 - 9x + 7) = 0$$

$$\Rightarrow 4(x+5)(2x^2 - 7x - 2x + 7) = 0$$

$$\Rightarrow 4(x+5)[x(2x-7) - 1(2x-7)] = 0$$

$$\Rightarrow 4(x+5)(2x-7)(x-1) = 0$$

$$\Rightarrow x = -5, 3.5, 1$$

113. (b) For only one solution $|A| \neq 0$

$$\begin{vmatrix} k & 2 & -1 \\ 0 & k-1 & -2 \\ 0 & 0 & k+2 \end{vmatrix} \neq 0$$

$$\Rightarrow k(k-1)(k+2) \neq 0$$

$$\Rightarrow k \neq 0, k \neq 1, k \neq -2. \therefore k = -1$$

114. (c) Let

$$A = \begin{vmatrix} -1 & 2 & 5 \\ 2 & -4 & a-4 \\ 1 & -2 & a+1 \end{vmatrix} \sim \begin{vmatrix} -1 & 2 & 5 \\ 0 & 0 & a+6 \\ 0 & 0 & a+6 \end{vmatrix}$$

$$[R_2 \rightarrow R_2 + 2R_1, R_3 \rightarrow R_3 + R_1]$$

clearly rank of A is 1 if $a = -6$

115. (c) Given : $ax^4 + bx^2 + c = 0$

Equation will be real if $D \geq 0$

$$\Rightarrow b^2 - 4ac \geq 0 \Rightarrow b^2 \geq 4ac$$

116. (a) Given : $\log_3 x + \log_3(\sqrt{x}) + \log_3(\sqrt[4]{x})$

$$+ \log_3 \sqrt[8]{x} + \log_3(\sqrt[16]{x}) + \dots = 4$$

$$\Rightarrow \log_3 x^{1 + \frac{1}{2} + \frac{1}{4} + \frac{1}{8} + \dots} = 4$$

$$\Rightarrow \log_3 x^{\frac{1}{1-\frac{1}{2}}} = 4 \quad \left[\because S_\infty = \frac{a}{1-r} \right]$$

$$\Rightarrow \log_3 x^2 = 4 \Rightarrow x^2 = 3^4 \Rightarrow x = 9$$

117. (a) $\left(x + \frac{1}{x}\right)^3 + \left(x + \frac{1}{x}\right) = 0$

$$\Rightarrow \left(x + \frac{1}{x}\right) + \left[\left(x + \frac{1}{x}\right)^2 + 1\right] = 0$$

$$\Rightarrow x + \frac{1}{x} = 0 \Rightarrow x^2 + 1 = 0 \Rightarrow x = \pm i$$

Thus, the given equation has no real roots.

118. (a) Given : H is the harmonic mean between P & Q

$$\therefore H = \frac{2PQ}{P+Q} \Rightarrow \frac{1}{H} = \frac{P+Q}{2PQ}$$

$$\Rightarrow \frac{2}{H} = \frac{1}{Q} + \frac{1}{P} \Rightarrow \frac{H}{P} + \frac{H}{Q} = 2$$

119. (c) We have $(\vec{a} + \vec{b}) \times (\vec{a} \times \vec{b})$

$$= \vec{a} \times (\vec{a} \times \vec{b}) + \vec{b} \times (\vec{a} \times \vec{b})$$

$$= (\vec{a} \cdot \vec{b})\vec{a} - (\vec{a} \cdot \vec{a})\vec{b} + (\vec{b} \cdot \vec{b})\vec{a} - (\vec{b} \cdot \vec{a})\vec{b}$$

$$= (\vec{a} \cdot \vec{b})(\vec{a} - \vec{b})$$

$$+ \vec{a} - \vec{b} \left(\vec{b} \cdot \vec{b} = \vec{b}^2 = 1, \vec{a} \cdot \vec{a} = \vec{a}^2 = 1 \right)$$

$$= (\vec{a} \cdot \vec{b} + 1)(\vec{a} - \vec{b})$$

$$= x(\vec{a} - \vec{b}) \text{ where } x = \vec{a} \cdot \vec{b} + 1 \text{ is a scalar}$$

\therefore The given vector is parallel to $\vec{a} - \vec{b}$.

120. (a) Given : A, B & C are three points with co-ordinates (1, 2, -1), (2, 0, 3) & (3, -1, 2) respectively.

Now, direction ratio's of

$$AB = 2 - 1, 0 - 2, 3 + 1 = 1, -2, 4 \text{ \&}$$

direction ratio's of

$$AC = 3 - 1, -1 - 2, 2 + 1 = 2, -3, 3$$

we know that

$$\cos \theta = \frac{a_1 a_2 + b_1 b_2 + c_1 c_2}{\sqrt{a_1^2 + b_1^2 + c_1^2} \cdot \sqrt{a_2^2 + b_2^2 + c_2^2}}$$

$$\Rightarrow \cos \theta = \frac{(1)(2) + (-2)(-3) + (4)(3)}{\sqrt{1+4+16} \cdot \sqrt{4+9+9}}$$

$$= \frac{2+6+12}{\sqrt{21} \cdot \sqrt{22}} = \frac{20}{\sqrt{462}}$$

$$\Rightarrow \sqrt{462} \cos \theta = 20$$