



collegebatch.com

click to campus

NEET 2014 Question Paper with Solution

National Eligibility-cum-Entrance Test (NEET) for admission to the undergraduate medical courses in all medical institutions including those governed under any other law

Download more NEET Previous Year Question Papers: [Click Here](#)

AIPMT 2014

Q.1 If force (F), velocity (V) and time (T) are taken as fundamental units, then the dimensions of mass are -

- (1) $[FVT^{-1}]$ (2) $[FVT^{-2}]$
 (3) $[FV^{-1}T^{-1}]$ (4) $[FV^{-1}T]$

Ans. [4]

Sol.

Assuming

$$M = F^a V^b T^c$$

Here we have to calculate value of a, b, c

Dimension of L.H.S. = R.H.S.

$$M^1 L^0 T^0 = (M^1 L^1 T^{-2})^a (L^1 T^{-1})^b (T^1)^c$$

$$M^1 L^0 T^0 = M^a L^{a+2a} T^{-2a-b+c}$$

$$M^1 L^0 T^0 = M^a L^{a+b} T^{-2a-b+c}$$

Comparing power of M

$$a = 1 \quad \dots(1)$$

Comparing power of L

$$a + b = 0$$

$$1 + b = 0$$

$$b = -1$$

Comparing power of T

$$0 = -2a - b + c$$

Putting value of 'a' and 'b'

$$0 = -2(1) - (-1) + c$$

$$0 = -1 + c$$

$$c = 1$$

So $M = F^1 V^{-1} T^1$

Q.2 A projectile is fired from the surface of the earth with a velocity of 5 ms^{-1} and angle θ with the horizontal. Another projectile fired from another planet with a velocity of 3 ms^{-1} at the same angle follows a trajectory which is identical with the trajectory of the projectile fired from the earth. The value of the acceleration due to gravity on the planet is (in ms^{-2}) - (given $g = 9.8 \text{ ms}^{-2}$)

- (1) 3.5 (2) 5.9
 (3) 16.3 (4) 110.8

Ans. [1]

Sol. Here range should be same

$$R_1 = R_2$$

$$\frac{u_e^2 \sin 2\theta}{2g_e} = \frac{u_p^2 \sin 2\theta}{2g_p}$$

$$\frac{5^2 \times \sin 2\theta}{2 \times 9.8} = \frac{3^2 \times \sin 2\theta}{2 \times g_p}$$

$$g_p = \frac{9.8 \times 9}{25} = 3.52 \text{ m/s}^2$$

Q.3 A particle is moving such that its position coordinates (x, y) are

(2m, 3m) at time t = 0.

(6m, 7m) at time t = 2 s and

(13m, 14m) at time t = 5s.

Average velocity vector $\left(\vec{V}_{av}\right)$ from t = 0 to

t = 5 s is -

(1) $\frac{1}{5}(13\hat{i} + 14\hat{j})$ (2) $\frac{7}{3}(\hat{i} + \hat{j})$

(3) $2(\hat{i} + \hat{j})$ (4) $\frac{11}{5}(\hat{i} + \hat{j})$

Ans. [4]

Sol. Average velocity = $\frac{\text{displacement}}{\text{time taken}}$

$$\begin{aligned} &= \frac{\vec{r}_2 - \vec{r}_1}{t_2 - t_1} \\ &= \frac{(13\hat{i} + 14\hat{j}) - (2\hat{i} + 3\hat{j})}{5 - 0} \\ &= \frac{11\hat{i} + 11\hat{j}}{5} \\ &= \frac{11}{5}(\hat{i} + \hat{j}) \end{aligned}$$

Q.4 A system consists of three masses m_1 , m_2 and m_3 connected by a string passing over a pulley P. The mass m_1 hangs freely and m_2 and m_3 are on a rough horizontal table (the coefficient of friction = μ). The pulley is frictionless and of negligible mass. The downward acceleration of mass m_1 is –

(Assume $m_1 = m_2 = m_3 = m$)

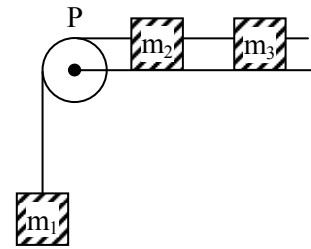

- (1) $\frac{g(1 - g\mu)}{9}$ (2) $\frac{2g\mu}{3}$
 (3) $\frac{g(1 - 2\mu)}{3}$ (4) $\frac{g(1 - 2\mu)}{2}$

Ans. [3]

Sol.

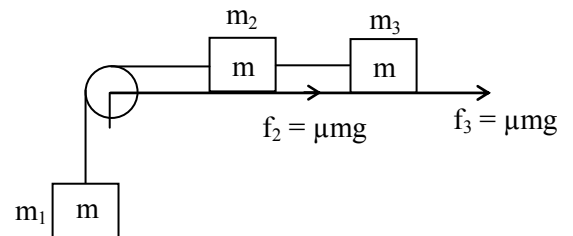

Here friction f_2 and f_3 will oppose the motion and weight ($m_1g = mg$) will support the motion

$$\begin{aligned} \text{so acceleration (a)} &= \frac{\text{Net force}}{\text{Total mass}} \\ a &= \frac{mg - \mu mg - \mu mg}{3m} \\ a &= \frac{mg(1 - 2\mu)}{3m} \\ a &= \frac{g(1 - 2\mu)}{3} \end{aligned}$$

Q.5 The force 'F' acting on a particle of mass 'm' is indicated by the force-time graph shown below. The change in momentum of the particle over the time interval from zero to 8 s is -

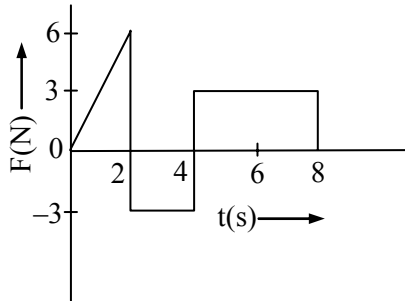

- (1) 24 Ns (2) 20 Ns
 (3) 12 Ns (4) 6 Ns

Ans. [3]

Sol.

Change in momentum will be equal to the area between F- t curve and time axis

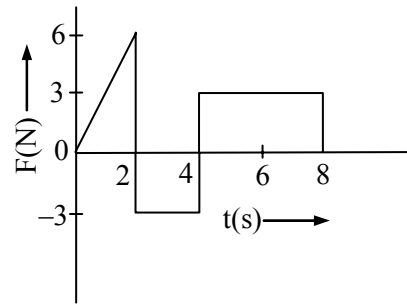

Area $\Delta p = 6 - 6 + 12 = 12 \text{ Ns}$

Q.6 A balloon with mass 'm' is descending down with an acceleration 'a' (where $a < g$). How much mass should be removed from it so that it starts moving up with an acceleration 'a' ?

- (1) $\frac{2ma}{g+a}$ (2) $\frac{2ma}{g-a}$
 (3) $\frac{ma}{g+a}$ (4) $\frac{ma}{g-a}$

Ans. [1]

Sol.

When balloon is descending

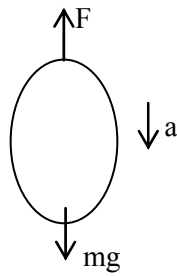

F is thrust force

$$mg - F = ma \dots(i)$$

When m' mass is removed balloon start moving up

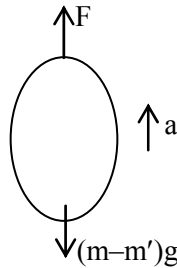

so

$$F - (m - m')g = (m - m')a \dots(ii)$$

From (i) + (ii)

$$mg - (m - m')g = ma + (m - m')a$$

$$m'g = ma + ma - m'a$$

$$m'(g + a) = 2ma$$

$$m' = \frac{2ma}{g + a}$$

Q.7 A body of mass $(4m)$ is lying in x - y plane at rest. It suddenly explodes into three pieces. Two pieces, each of mass (m) move perpendicular to each other with equal speeds (v) . The total kinetic energy generated due to explosion is -

- (1) mv^2 (2) $3/2 mv^2$
 (3) $2 mv^2$ (4) $4 mv^2$

Ans. [2]

Sol.

Using law of conservation of linear momentum

momentum before explosion = after explosion

$$0 = \vec{p}_1 + \vec{p}_2 + \vec{p}_3$$

$$\vec{p}_3 = -(\vec{p}_1 + \vec{p}_2)$$

$$|\vec{p}_3| = |-(\vec{p}_1 + \vec{p}_2)| = \sqrt{p_1^2 + p_2^2} \quad \because p_1 \perp p_2$$

$$m_3 v_3 = \sqrt{(m_1 v_1)^2 + (m_2 v_2)^2}$$

[given $m_1 = m_2 = m$; $v_1 = v_2 = v$; $m_3 = 2m$]

$$2m v_3 = \sqrt{(mv)^2 + (mv)^2}$$

$$v_3 = \frac{\sqrt{2}mv}{2m} = \frac{v}{\sqrt{2}}$$

so total kinetic energy generated in the explosion

$$\Delta K = \frac{1}{2}mv^2 + \frac{1}{2}mv^2 + \frac{1}{2}2m\left(\frac{v}{\sqrt{2}}\right)^2$$

$$= \frac{3}{2}mv^2$$

Q.8 The oscillation of a body on a smooth horizontal surface is represents by the equation

$$X = A \cos(\omega t)$$

where X = displacement at time t

ω = frequency of oscillation

Which one of the following graph shows correctly the variation 'a' with 't' ?

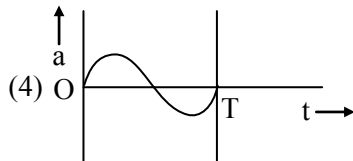
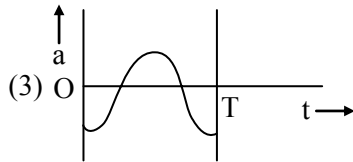
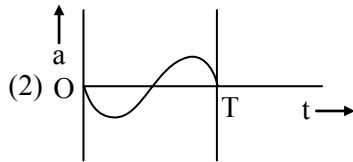
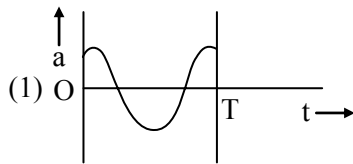

Here a = acceleration at time t
 T = time period

Ans. [3]

Sol.

$$X = A \cos \omega t$$

$$V = \frac{dX}{dt} = -A\omega \sin \omega t$$

$$a = \frac{dV}{dt} = -A\omega^2 \cos \omega t$$

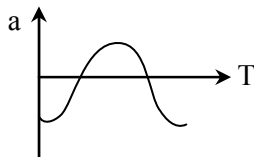

Q.9 A solid cylinder of mass 50 kg and radius 0.5 m is free to rotate about the horizontal axis. A massless string is wound round the cylinder with one end attached to it and

other hanging freely. Tension in the string required to produce an angular acceleration of 2 revolutions s^{-2} is -

- (1) 25 N (2) 50 N
 (3) 78.5 N (4) 157 N

Ans. [4]

Sol.

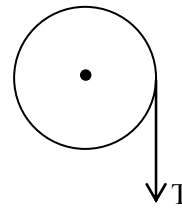

given $m = 50$ kg, $R = 0.5$ m

$$\alpha = 2 \text{ rev./s}^2 = 2 \times 2\pi \text{ rad/s}^2$$

here tension will produce the torque

$$\tau = I\alpha$$

$$TR = \frac{MR^2}{2} \alpha$$

$$T(0.5) = \frac{50 \times (0.5)^2}{2} \times 2 \times 2\pi$$

$$T = 157 \text{ N}$$

Q.10 The ratio of the accelerations for a solid sphere (mass 'm' and radius 'R') rolling down an incline of angle ' θ ' without slipping and slipping down the incline without rolling is -

- (1) 5 : 7 (2) 2 : 3
 (3) 2 : 5 (4) 7 : 5

Ans. [1]

Sol.

When sphere is rolling

$$a_r = \frac{g \sin \theta}{1 + k^2/R^2}$$

when sphere is sliding

$$a_s = \frac{g \sin \theta}{1 + 0} \quad \left[\text{for sliding } \frac{k^2}{R^2} = 0 \right]$$

$$\frac{a_r}{a_s} = \frac{\frac{g \sin \theta}{1 + \frac{2}{5}}}{g \sin \theta} = \frac{5}{7}$$

Q.11 A black hole is an object whose gravitational field is so strong that even light cannot escape from it. To what approximate radius would earth (mass = 5.98×10^{24} kg) have to be compressed to be a black hole ?

- (1) 10^{-9} m (2) 10^{-6} m
 (3) 10^{-2} m (4) 100 m

Ans. [3]

Sol.

Escape velocity on a black hole should be more or equal to speed of light

$$c \leq v_{es}$$

$$c \leq \sqrt{\frac{2GM}{R}}$$

$$3 \times 10^8 \leq \sqrt{\frac{2 \times 6.67 \times 10^{-11} \times 5.98 \times 10^{24}}{R}}$$

$$9 \times 10^{16} \leq \frac{2 \times 6.67 \times 10^{-11} \times 5.98 \times 10^{24}}{R}$$

$$R \leq \frac{2 \times 6.67 \times 5.98 \times 10^{13}}{9 \times 10^{16}}$$

$$R \leq 8.86 \times 10^{-3}$$

$$R \simeq 10^{-2} \text{ m}$$

Q.12 Dependence of intensity of gravitational field (E) of earth with distance (r) from centre of earth is correctly represented by -

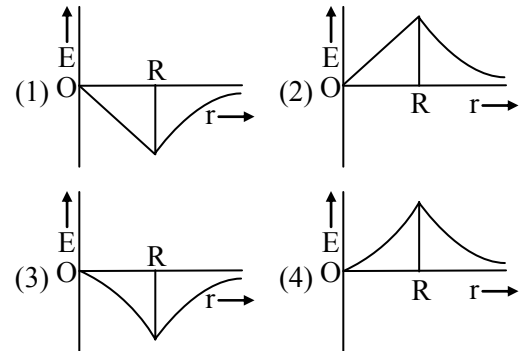

Ans. [1]

Sol. For solid sphere gravitational intensity

$$\text{When } r > R \quad E = -\frac{GM}{R^3}r$$

$$r = R \quad E = -\frac{GM}{R^2}$$

$$r > R \quad E = -\frac{GM}{r^2}$$

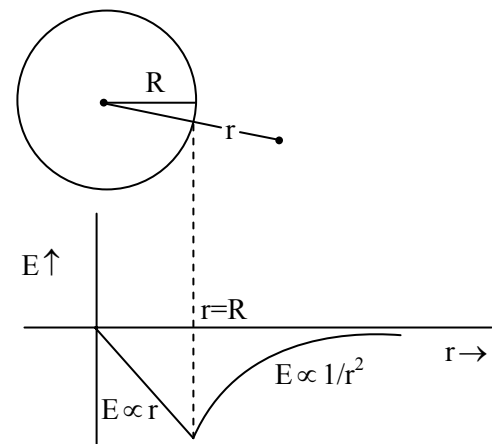

Q.13 Copper of fixed volume 'V' is drawn into wire of length 'l'. When this wire is subjected to a constant force 'F', the extension produced in the wire is 'Δl'. Which of the following graphs is a straight line ?

- (1) Δl versus 1/l (2) Δl versus l²
 (3) Δl versus 1/l² (4) Δl versus l

Ans. [2]

Sol.
$$Y = \frac{\text{stress}}{\text{strain}} = \frac{F/A}{\frac{\Delta l}{l}} = \frac{Fl}{\Delta l A}$$

$$\Delta l = \left(\frac{F}{YA} \right) l$$

Here F = constant ; Y = constant

V = Al = constant

$$A \propto \frac{1}{l}$$

$$\Delta l \propto \frac{A}{l} \propto l^2$$

$$\Delta l \propto l^2$$

Graph between Δl and l² is straight line.

Q.14 A certain number of spherical drops of a liquid of radius 'r' coalesce to form a single drop of radius 'R' and volume 'V'. If 'T' is the surface tension of the liquid, then -

(1) energy = 4VT $\left(\frac{1}{r} - \frac{1}{R} \right)$ is released

(2) energy = 3VT $\left(\frac{1}{r} + \frac{1}{R} \right)$ is absorbed

(3) energy = 3VT $\left(\frac{1}{r} - \frac{1}{R} \right)$ is released

(4) energy is neither released nor absorbed

Ans. [3]

Sol.

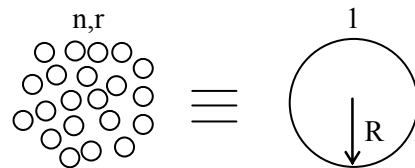

$$\text{Volume same} \Rightarrow n \left(\frac{4}{3} \pi r^3 \right) = \frac{4}{3} \pi R^3$$

$$\boxed{R = (n)^{1/3} r}$$

$$n = \frac{R^3}{r^3}$$

$$U = T \Delta A$$

$$= T[4\pi R^2 - n4\pi r^2]$$

$$= 4\pi T[R^2 - nr^2]$$

$$= 4\pi T \left[R^2 - \frac{R^3}{r^3} r^2 \right]$$

$$= 4\pi R^3 T \left[\frac{1}{R} - \frac{1}{r} \right]$$

$$= 3 \left(\frac{4}{3} \pi R^3 \right) T \left(\frac{1}{R} - \frac{1}{r} \right)$$

$$\boxed{U = 3VT \left(\frac{1}{R} - \frac{1}{r} \right)} \quad (R > r)$$

$$\boxed{U = 3VT \left(\frac{1}{r} - \frac{1}{R} \right)} \text{ is released}$$

Q.15 Steam at 100°C is passed into 20 g of water at 10°C. When water acquires a temperature of 80°C, the mass of water present will be -

[Take specific heat of water = 1 cal g⁻¹°C⁻¹ and latent heat of steam = 540 cal g⁻¹]

(1) 24 g (2) 31.5 g

(3) 42.5 g (4) 22.5 g

Ans. [4]

Sol.

$$\Delta Q_{\text{gain}} = M_w C_w (80 - 10)$$

$$\Delta Q_{\text{loss}} = M_s L_v + M_s C_w (100 - 80)$$

$$\Delta Q_{\text{gain}} = \Delta Q_{\text{loss}}$$

$$20 \times 1 \times 70 = M_s (540) + M_s (1)(80)$$

$$M_s = \frac{1400}{620} \text{ gm} = 2.2580 \text{ gm}$$

$$M_{\text{net}} = M_w + M_s$$

$$= 20 + 2.25$$

$$= 22.5 \text{ gm}$$

Q.16 Certain quantity of water cools from 70°C to 60°C in the first 5 minutes and 60°C to 54°C in the next 5 minutes. The temperature of the surroundings is -

(1) 45°C (2) 20°C

(3) 42°C (4) 10°C

Ans. [1]

Sol. From Newtons law of cooling

$$\left(\frac{T_1 - T_2}{t} \right) = C_1 \left(\frac{T_1 + T_2}{2} - T_0 \right)$$

$$\left(\frac{70 - 60}{5} \right) = C_1 \left(\frac{70 + 60}{2} - T_0 \right) \dots (1)$$

$$\left(\frac{60 - 54}{5} \right) = C_1 \left(\frac{60 + 54}{2} - T_0 \right) \dots (2)$$

$$\frac{10}{5} = \frac{C_1 (65 - T_0)}{C_1 (57 - T_0)}$$

$$10(57 - T_0) = 6(65 - T_0)$$

$$570 - 10T_0 = 390 - 6T_0$$

$$4T_0 = 570 - 390$$

$$T_0 = 45^\circ\text{C}$$

Q.17 A monoatomic gas at a pressure P , having a volume V expands isothermally to a volume $2V$ and then adiabatically to a volume $16V$. The final pressure of the gas is – (take $\gamma = 5/3$)

- (1) $64 P$ (2) $32 P$
 (3) $P/64$ (4) $16 P$

Ans. [3]

Sol. I.T Process :-

$$P_1 V_1 = P_2 V_2$$

$$P_2 = P_1 \left(\frac{V_1}{2V} \right) = \frac{P_1}{2}$$

A.D process:-

$$P_2 V_2^\gamma = P_3 V_3^\gamma$$

$$P_3 = P_2 \left(\frac{V_2}{V_3} \right)^\gamma$$

$$= \frac{P_1}{2} \left(\frac{2V}{10V} \right)^{5/3}$$

$$= \frac{P}{2} \left(\frac{1}{2^3} \right)^{5/3}$$

$$= \frac{P}{2} \left(\frac{1}{2^5} \right)$$

$$P_3 = \frac{P}{64}$$

Q.18 A thermodynamic system undergoes cyclic process ABCDA as shown in figure. The work done by the system in the cycle is -

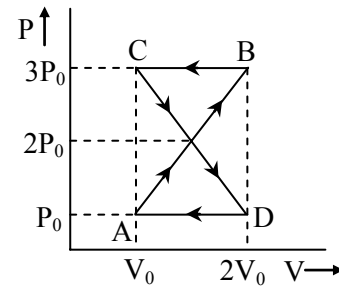

- (1) $P_0 V_0$ (2) $2P_0 V_0$
 (3) $\frac{P_0 V_0}{2}$ (4) Zero

Ans. [4]

Sol.

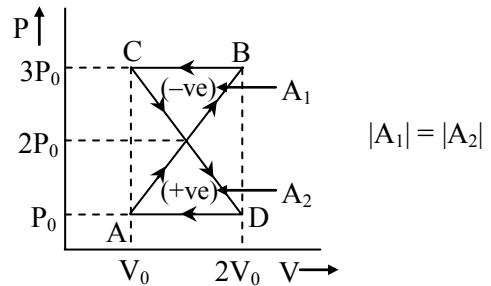

$$W_{\text{net}} = A_1 - A_2 = 0$$

Q.19 The mean free path of molecules of a gas, (radius 'r') is inversely proportional to -

- (1) r^3 (2) r^2
 (3) r (4) \sqrt{r}

Ans. [2]

Sol. $\lambda_M = \frac{1}{\sqrt{2} \pi d^2 n}$ [d = diameter of gas molecule = $r/2$]

$$\lambda_M \propto \frac{1}{d^2} \propto \frac{1}{r^2}$$

Q.20 If n_1 , n_2 and n_3 are the fundamental frequencies of three segments into which a string is divided, then the original fundamental frequency n of the string is given by -

$$(1) \frac{1}{n} = \frac{1}{n_1} + \frac{1}{n_2} + \frac{1}{n_3}$$

$$(2) \frac{1}{\sqrt{n}} = \frac{1}{\sqrt{n_1}} + \frac{1}{\sqrt{n_2}} + \frac{1}{\sqrt{n_3}}$$

$$(3) \sqrt{n} = \sqrt{n_1} + \sqrt{n_2} + \sqrt{n_3}$$

$$(4) n = n_1 + n_2 + n_3$$

Ans. [1]

Sol.

$$l = l_1 + l_2 + l_3$$

$$n_{\text{string}} = \frac{1}{2l} \sqrt{\frac{T}{m}} \propto \frac{1}{l}$$

$$l \propto \frac{1}{n}$$

$$\frac{1}{n} = \frac{1}{n_1} + \frac{1}{n_2} + \frac{1}{n_3}$$

Q.21 The number of possible natural oscillations of air column in a pipe closed at one end of length 85 cm whose frequencies lie below 1250 Hz are - (velocity of sound = 340 ms^{-1})

- (1) 4 (2) 5 (3) 7 (4) 6

Ans. [4]

Sol.
$$n_{\text{fundamental}} = \frac{V}{4l} = \frac{340}{4 \times \frac{85}{100}} = 100 \text{ Hz}$$

Possible frequency of C.O.P. = 1 : 3 : 5 : 7 : 9 : 11

$$n_1 = 100 < 1250$$

$$n_2 = 300 < 1250$$

$$n_3 = 500 < 1250$$

$$n_4 = 700 < 1250$$

$$n_5 = 900 < 1250$$

$$n_6 = 1100 < 1250$$

$$n_7 = 1300 > 1250$$

Now possible frequencies = 6.

Q.22 A speeding motorcyclist sees traffic jam ahead of him. He slows down to 36 km/hour. He finds that traffic has eased and a car moving ahead of him at 18 km/hour is honking at a frequency of 1392 Hz. If the speed of sound is 343 m/s, the frequency of the honk as heard by him will be -

- (1) 1332 Hz (2) 1372 Hz
(3) 1412 Hz (4) 1454 Hz

Ans. [3]

Sol.

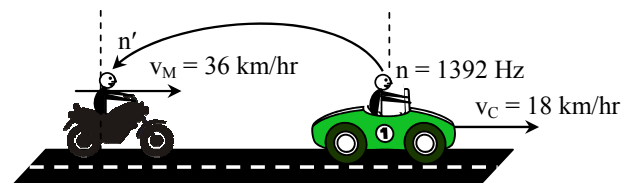

$$\begin{aligned} n' &= n \left(\frac{v + v_0}{v + v_s} \right) & \left| \begin{array}{l} v_C = 18 \times \frac{5}{18} = 5 \text{ m/s} \\ v_M = 36 \times \frac{5}{18} = 10 \text{ m/s} \end{array} \right. \\ &= n \left(\frac{v + v_M}{v + v_C} \right) \\ &= 1392 \left(\frac{343 + 10}{343 + 5} \right) \\ &= 1392 \left(\frac{353}{348} \right) = 1412 \text{ Hz} \end{aligned}$$

Q.23 Two thin dielectric slabs of dielectric constants K_1 and K_2 ($K_1 < K_2$) are inserted between plates of a parallel plate capacitor, as shown in the figure. The variation of electric field 'E' between the plates with distance 'd' as measured from plate P is correctly shown by :

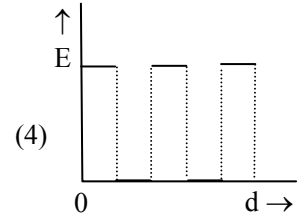
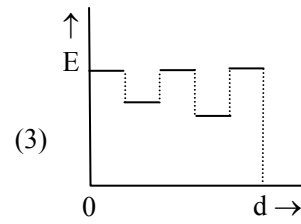
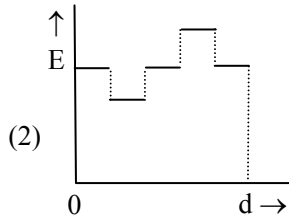
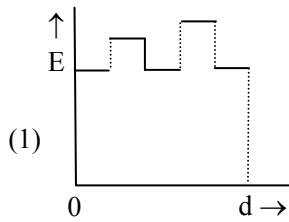
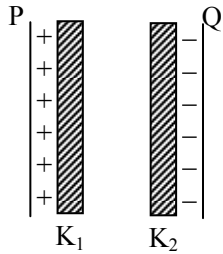

Ans. [3]

Sol.
$$E = \frac{\sigma}{\epsilon_0 \epsilon_r} = \frac{Q}{A \epsilon_0 \epsilon_r} \propto \frac{1}{\epsilon_r}$$

$E_{\text{air}} > E_1 > E_2$

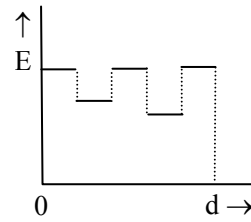

Q.24 A conducting sphere of radius R is given a charge Q. The electric potential and the electric field at the centre of the sphere respectively are :

(1) Zero and $\frac{Q}{4\pi\epsilon_0 R^2}$

(2) $\frac{Q}{4\pi\epsilon_0 R}$ and Zero

(3) $\frac{Q}{4\pi\epsilon_0 R}$ and $\frac{Q}{4\pi\epsilon_0 R^2}$

(4) Both are zero

Ans. [2]

Sol.

In conducting sphere there no charge in sphere

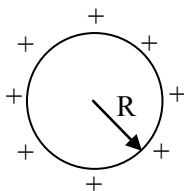

$$E_{in} = E_{centre} = 0$$

$$V_{in} = V_{centre} = \text{constant} = \frac{KQ}{R} = \frac{Q}{4\pi\epsilon_0 R}$$

Q.25 In a region the potential is represented by $V(x, y, z) = 6x - 8xy - 8y + 6yz$, where V is in volts and x, y, z are in meters. The electric force experienced by a charge of 2 coulomb situated at point (1, 1, 1) is

(1) $6\sqrt{5}N$ (2) 30N

(3) 24 N (4) $4\sqrt{35}N$

Ans. [4]

Sol.

$$V = 6x - 8xy - 8y + 6yz$$

$$\vec{E} = -\frac{\partial V}{\partial x}\hat{i} - \frac{\partial V}{\partial y}\hat{j} - \frac{\partial V}{\partial z}\hat{k}$$

$$\frac{\partial V}{\partial x} = \frac{\partial}{\partial x}(6x - 8xy - 8y + 6yz)$$

$$= (6 - 8y - 0 + 0)_{1,1,1} = -2$$

$$\frac{\partial V}{\partial y} = \frac{\partial}{\partial y}(6x - 8xy - 8y + 6yz)$$

$$= (0 - 8x - 8 + 6z)_{1,1,1} = -10$$

$$\frac{\partial V}{\partial z} = \frac{\partial}{\partial z}(6x - 8xy - 8y + 6yz)$$

$$= (0 - 0 - 0 + 6y)_{1,1,1} = 6$$

$$\vec{E} = 2\hat{i} + 10\hat{j} - 6\hat{k}$$

$$E = \sqrt{(2)^2 + (10)^2 + (6)^2} = \sqrt{4 + 100 + 36}$$

$$= \sqrt{140}$$

$$E = 2\sqrt{35}$$

$$F_e = qE = 2 \times 2\sqrt{35} = 4\sqrt{35}$$

Q.26 Two cities are 150 km apart. Electric power is sent from one city to another city through copper wires. The fall of potential per km is 8 volt and the average resistance per km is 0.5Ω . The power loss in the wire is :

(1) 19.2 W (2) 19.2 kW

(3) 19.2 J (4) 12.2 kW

Ans. [2]

Sol. CP Students may find similar question in CP Exercise Sheet: [Chapter : EMI, Exercise # 2, Page No. 174, Q. 87]

Total voltage drop across wire = 150×8
 = 1200 volt

Total resistance of wire
 = $150 \times 0.5 = 75 \Omega$

\therefore current through wire

$$I = \frac{V}{R} = \frac{1200}{75} = 16 \text{ Ampere}$$

$$\begin{aligned} \therefore \text{Power loss} &= I^2 R \\ &= (16)^2 \times 75 \\ &= 19200 \text{ W} \\ &= 19.2 \text{ kW} \end{aligned}$$

Q.27 The resistance in the two arms of the meter bridge are 5Ω and $R \Omega$, respectively. When the resistance R is shunted with an equal resistance, the new balance points is at $1.6 l_1$. The resistance 'R', is :

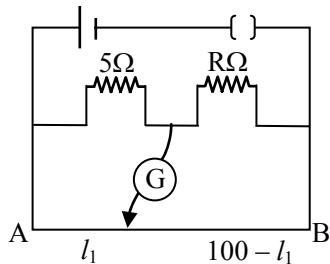

- (1) 10Ω (2) 15Ω
 (3) 20Ω (4) 25Ω

Ans. [2]

Sol.

From balanced wheat stone bridge

$$\frac{P}{Q} = \frac{R}{S}$$

$$\frac{5}{R} = \frac{l_1}{100 - l_1} \quad \dots(1)$$

$$\frac{5}{R/2} = \frac{1.6l_1}{100 - 1.6l_1} \quad \dots(2)$$

by dividing (1) by (2)

$$\frac{1}{2} = \frac{100 - 1.6l_1}{1.6(100 - l_1)}$$

$$160 - 1.6l_1 = 200 - 3.2 l_1$$

$$l_1 = 25 \text{ cm}$$

put that value in equation (1)

$$\frac{5}{R} = \frac{25}{100 - 25} \Rightarrow R = 15 \Omega$$

Q.28 A potentiometer circuit has been set up for finding the internal resistance of a given cell. The main battery, used across the potentiometer wire, has an emf of 2.0 V and a negligible internal resistance. The potentiometer wire itself is 4m long. When the resistance, R , connected across the given cell, has values of

- (i) infinity (ii) 9.5Ω

the 'balancing lengths', on the potentiometer wire are found to be 3 m and 2.85 m, respectively. The value of internal resistance of the cell is

- (1) 0.25Ω (2) 0.95Ω
 (3) 0.5Ω (4) 0.75Ω

Ans. [3]

Sol.

Internal resistance of cell

$$r = \left(\frac{l_1 - l_2}{l_2} \right) (R)$$

$$= \left(\frac{3 - 2.85}{2.85} \right) (9.5)$$

$$= 0.5 \Omega$$

Q.29 Following figures show the arrangement of bar magnets in different configurations. Each magnet has magnetic dipole moment \vec{m} . Which configuration has highest net magnetic dipole moment ?

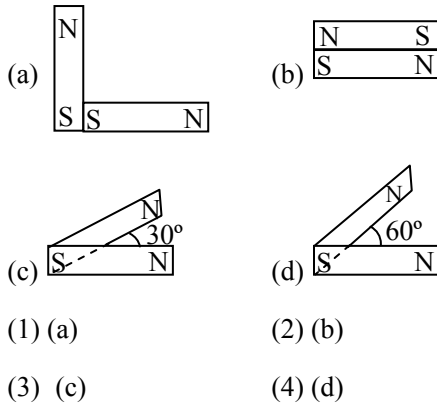

Ans. [3]

Sol. $M_{\text{net}} = \sqrt{M_1^2 + M_2^2 + 2M_1M_2 \cos \theta}$

when angle (θ) between two vector increases. Resultant vector (M_{net}) decreases so M_{net} is max. when angle (θ) is minimum.

Q.30 In an ammeter 0.2% of main current passes through the galvanometer. If resistance of galvanometer is G, the resistance of ammeter will be :

- (1) $\frac{1}{499} G$ (2) $\frac{499}{500} G$
 (3) $\frac{1}{500} G$ (4) $\frac{500}{499} G$

Ans. [3]

Sol.

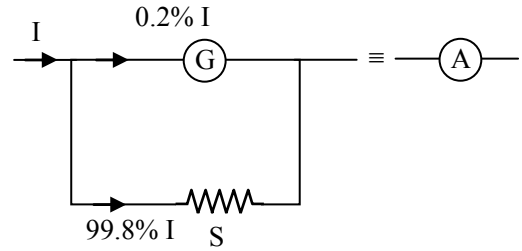

In parallel

$$I \propto \frac{1}{R}$$

$$\frac{G}{S} = \frac{99.8}{0.2} \Rightarrow S = \frac{G}{499}$$

$$\therefore R_{(A)} = S \parallel R_g$$

$$= \frac{G}{500}$$

Q.31 Two identical long conducting wires AOB and COD are placed at right angle to each other, with one above other such that 'O' is their common point for the two. The wires carry I_1 and I_2 currents, respectively. Point 'P' is lying at distance 'd' from 'O' along a direction perpendicular to the plane containing the wires. The magnetic field at the point 'P' will be :

- (1) $\frac{\mu_0}{2\pi d} \left(\frac{I_1}{I_2} \right)$ (2) $\frac{\mu_0}{2\pi d} (I_1 + I_2)$
 (3) $\frac{\mu_0}{2\pi d} (I_1^2 - I_2^2)$ (4) $\frac{\mu_0}{2\pi d} (I_1^2 + I_2^2)^{1/2}$

Ans. [4]

Sol.

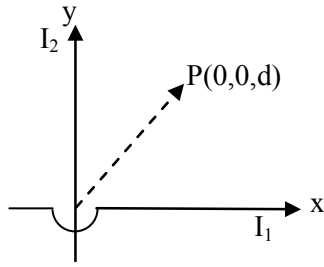

$$\vec{B}_1 = \frac{\mu_0 I_1}{2\pi d} (-\hat{j})$$

$$\vec{B}_2 = \frac{\mu_0 I_2}{2\pi d} (+\hat{i})$$

$$B = \sqrt{B_1^2 + B_2^2} = \frac{\mu_0}{2\pi d} \sqrt{I_1^2 + I_2^2}$$

Q.32 A thin semicircular conducting ring (PQR) of radius 'r' is falling with its plane vertical in a horizontal magnetic field B, as shown in figure. The potential difference developed across the ring when its speed is v, is :

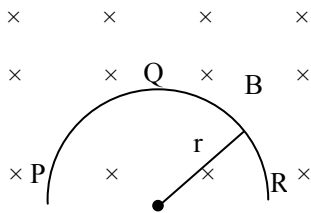

- (1) Zero
- (2) $Bv\pi r^2/2$ and P is at higher potential
- (3) πrBv and R is at higher potential
- (4) $2rBv$ and R is at higher potential

Ans. [4]

Sol.

$$e = B v(\ell_i - \ell_f)$$

where $(\ell_i - \ell_f)$ is displacement between end of semicircular ring

$$e = B v(2R)$$

Q.33 A transformer having efficiency of 90% is working on 200 V and 3 kW power supply. If the current in the secondary coil is 6A, the voltage across the secondary coil and the current in the primary coil respectively are :

- (1) 300 V, 15 A
- (2) 450 V, 15 A
- (3) 450 V, 13.5 A
- (4) 600 V, 15 A

Ans. [2]

Sol.

$$\text{Power of primary} = V_p I_p = 3 \text{ kW}$$

$$\Rightarrow I_p = \frac{3000}{V_p} = \frac{3000}{200} = 15 \text{ A}$$

$$\% \eta = \frac{V_s I_s}{V_p I_p} \times 100$$

$$\frac{90}{100} = \frac{V_s I_s}{V_p I_p}$$

$$\begin{aligned} \Rightarrow V_s &= \frac{0.9 V_p I_p}{I_s} = \frac{0.9 \times 3000}{6} \\ &= 450 \text{ V} \end{aligned}$$

Q.34 Light with an energy flux of $25 \times 10^4 \text{ W m}^{-2}$ falls on a perfectly reflecting surface at normal incidence. If the surface area is 15 cm^2 , the average force exerted on the surface is

- (1) $1.25 \times 10^{-6} \text{ N}$ (2) $2.50 \times 10^{-6} \text{ N}$
(3) $1.20 \times 10^{-6} \text{ N}$ (4) $3.0 \times 10^{-6} \text{ N}$

Ans. [2]

Sol. $I = 25 \times 10^4 \frac{\text{W}}{\text{m}^2}$

$$A = 15 \text{ cm}^2$$

Pressure exerted on surface if it is perfectly reflecting

$$Pr = 2 \left(\frac{I}{C} \right) = \frac{F}{A}$$

$$F = \frac{2IA}{C} = \frac{2 \times 25 \times 10^4}{3 \times 10^8} \times 15 \times 10^{-4}$$

$$= 2.50 \times 10^{-6} \text{ N}$$

Q.35 A beam of light of $\lambda = 600 \text{ nm}$ from a distant source falls on a single slit 1 mm wide and the resulting diffraction pattern is observed on a screen 2 m away. The distance between first dark fringes on either side of the central bright fringe is :

- (1) 1.2 cm (2) 1.2 mm
(3) 2.4 cm (4) 2.4 mm

Ans. [4]

Sol.

$$\text{given } \lambda = 600 \times 10^{-9} \text{ m}$$

$$D = 2 \text{ m}$$

$$d = 1 \text{ mm} = 10^{-3} \text{ m}$$

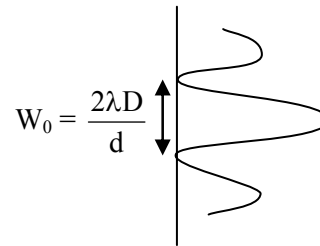

width of the central maxima

$$\begin{aligned} W_0 &= \frac{2\lambda D}{d} = \frac{2 \times 600 \times 10^{-9} \times 2}{10^{-3}} \\ &= 2.4 \times 10^{-3} \text{ m} \\ &= 2.4 \text{ mm} \end{aligned}$$

Q.36 In the Young's double-slit experiment, the intensity of light at a point on the screen where the path difference is λ is K , (λ being the wave length of light used). The intensity at a point where the path difference is $\lambda/4$, will be

- (1) K (2) $K/4$
(3) $K/2$ (4) Zero

Ans. [3]

Sol. $\Delta\phi = \frac{2\pi}{\lambda}(\Delta x) = \frac{2\pi}{\lambda}(\lambda) = 2\pi$

* $I = I_0 + I_0 + 2\sqrt{I_0 I_0} \cos 2\pi$

$I = 4I_0 = k$

* $\Delta\phi = \frac{2\pi}{\lambda}\left(\frac{\lambda}{4}\right) = \frac{\pi}{2}$

$I = I_0 + I_0 + 2\sqrt{I_0 I_0} \cos \pi/2$

$I = 2I_0 = k/2$

Q.37 If the focal length of objective lens is increased then magnifying power of :

- (1) microscope will increase but that of telescope decrease
- (2) microscope and telescope both will increase
- (3) microscope and telescope both will decrease
- (4) microscope will decrease but that of telescope will increase

Ans. [4]

Sol. * For telescope M.P. = $\frac{f_o}{f_e}$ ($f_o \uparrow \Rightarrow$ M.P. \uparrow)

on increasing f_o , M.P is \uparrow

* For microscope M.P. $\approx \frac{v_o}{u_o} \left(1 + \frac{D}{f_e}\right)$

$\approx \frac{L}{f_o} \left(1 + \frac{D}{f_e}\right)$

on increasing f_o , M.P. is \downarrow

Q.38 The angle of a prism is 'A'. One of its refracting surfaces is silvered. Light rays falling at an angle of incident $2A$ on the first surface returns back through the same path after suffering reflection at the silvered surface. The refractive index μ , of the prism is

- (1) $2 \sin A$
- (2) $2 \cos A$
- (3) $\frac{1}{2} \cos A$
- (4) $\tan A$

Ans. [2]

Sol.

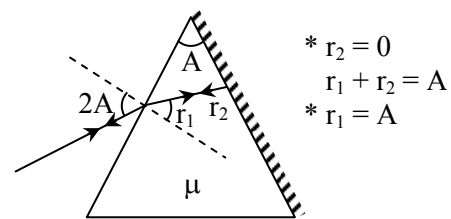

(1) $\sin 2A = \mu \sin A$
 $2 \sin A \cos A = \mu \sin A$
 $\mu = 2 \cos A$

Q.39 When the energy of the incident radiation is increased by 20%, the kinetic energy of the photoelectrons emitted from a metal surface increased from 0.5 eV to 0.8 eV. The work function of the metal is

- (1) 0.65 eV
- (2) 1.0 eV
- (3) 1.3 eV
- (4) 1.5 eV

Ans. [2]

Sol. $K. E_{e^-} = E_{ph} - W$

$0.5 = E - W \quad \dots(i) \times 1.20$

Q.43 A radio isotope 'X' with a half life 1.4×10^9 years decays to 'Y' which is stable. A sample of the rock from a cave was found to contain 'X' and 'Y' in the ratio 1 : 7. The age of the rock is

- (1) 1.96×10^9 years (2) 3.92×10^9 years
 (3) 4.20×10^9 years (4) 8.40×10^9 years

Ans. [3]

Sol. X : Y = 1 : 7

↑ ↑

Active stable

$$\text{Active part of sample A.P.} = \frac{X}{X+Y} = \frac{1}{8}$$

$$* \text{ A.P} = \frac{1}{8} = \frac{1}{2^n}$$

$$* n = 3$$

$$* t = nT_{1/2} = 3 \times 1.4 \times 10^9 \\ = 4.2 \times 10^9 \text{ year}$$

Q.44 The given graph represents V-I characteristic for a semiconductor device.

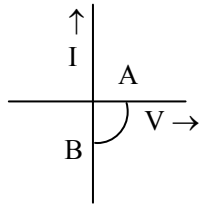

Which of the following statement is correct?

- (1) It is V-I characteristic for solar cell where, point A represents open circuit voltage and point B short circuit current
 (2) It is for a solar cell and points A and B represent open circuit voltage and current, respectively

(3) It is for a photodiode and points A and B represent open circuit voltage and current, respectively

(4) It is for a LED and points A and B represent open circuit voltage and short circuit current, respectively

Ans. [1]

Sol. In p-n junction barrier potential is n to p → so it is open circuit voltage when length incident on depletion layer in solar cell then extra charge carrier are generated which flow current p to n. (so it is short circuit current)

Q.45 The barrier potential of a p-n junction depends on :

- (a) type of semiconductor material
 (b) amount of doping
 (c) temperature

Which one of the following is correct?

- (1) (a) and (b) only
 (2) (b) only
 (3) (b) and (c) only
 (4) (a), (b) and (c)

Ans. [4]

Sol. (a) Potential barrier for Ge p-n junction is 0.3 V

Potential barrier for Si p-n junction is 0.7 V

- (b) doping increase potential barrier (depletion width) decreases
 (c) temperature increase potential barrier (depletion width) increases

Q.46 What is the maximum number of orbitals that can be identified with the following quantum numbers $n = 3, \ell = 1, m_\ell = 0$

- (1) 1 (2) 2 (3) 3 (4) 4

Ans. [1]

Sol.

$n = 3$ means 3rd shell

$\ell = 1$ means p-subshell

$m_\ell = 0$ means orbital of p-subshell

\therefore Answer is one orbital

Q.47 Calculate the energy in joule corresponding to light of wavelength 45 nm: (Planck constant $h = 6.63 \times 10^{-34}$ Js, speed of light $c = 3 \times 10^8$ ms⁻¹)

- (1) 6.67×10^{15} (2) 6.67×10^{11}
(3) 4.42×10^{-15} (4) 4.42×10^{-18}

Ans. [4]

Sol.

$$\text{Energy}(E) = \frac{hc}{\lambda}$$

$$\therefore E = \left(\frac{6.63 \times 10^{-34} \times 3 \times 10^8}{45 \times 10^{-9}} \right) \text{J}$$

$$E = 4.42 \times 10^{-18} \text{ J}$$

Q.48 Equal masses of H₂, O₂ and methane have been taken in a container of volume V at temperature 27°C in identical conditions. The ratio of the volumes of gases H₂ : O₂ : methane would be:

- (1) 8 : 16 : 1 (2) 16 : 8 : 1
(3) 16 : 1 : 2 (4) 8 : 1 : 2

Ans. [3]

Sol.

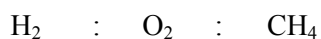

Assuming weight w w w

$$\therefore \text{moles } \frac{w}{2} \qquad \frac{w}{32} \qquad \frac{w}{16}$$

So mole ratio or volume ratio $\frac{w}{2} : \frac{w}{32} : \frac{w}{16}$

means $16 : 1 : 2$

Q.49 If a is the length of the side of a cube, the distance between the body centred atom and one corner atom in the cube will be:

(1) $\frac{2}{\sqrt{3}}a$ (2) $\frac{4}{\sqrt{3}}a$

(3) $\frac{\sqrt{3}}{4}a$ (4) $\frac{\sqrt{3}}{2}a$

Ans. [4]

Sol.

BCC unit cell:

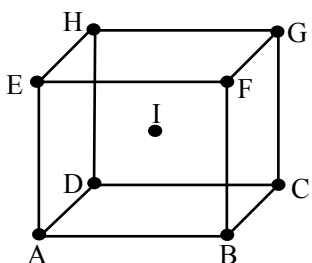

According to $\triangle ABC$

$$AC^2 = AB^2 + BC^2$$

$$AC^2 = a^2 + a^2$$

$$AC = \sqrt{2}a$$

According to $\triangle ACG$ $AG^2 = AC^2 + CG^2$

$$AG^2 = 2a^2 + a^2$$

$$\therefore AG = \sqrt{3}a$$

$$\therefore \text{AI distance} = \frac{AG}{2} = \frac{\sqrt{3}a}{2}$$

Q.50 Which property of colloids is not dependent on the charge on colloidal particles ?

- (1) Coagulation (2) Electrophoresis
(3) Electro-osmosis (4) Tyndall effect

Ans. [4]

Sol.

Theory problem

Q.51 Which of the following salts will give highest pH in water ?

- (1) KCl (2) NaCl
(3) Na_2CO_3 (4) CuSO_4

Ans. [3]

Sol. CP Students may find same question in CP Exercise Sheet: [Chapter : Ionic Equilibrium, Level # 3(B)-, Page No.167, Q. 9]

Na_2CO_2 is a salt of weak acid and strong base.

So its pH will be maximum

Q.52 Of the following 0.10m aqueous solutions, which one will exhibit the largest freezing point depression ?

- (1) KCl (2) $\text{C}_6\text{H}_{12}\text{O}_6$
(3) $\text{Al}_2(\text{SO}_4)_3$ (4) K_2SO_4

Ans. [3]

Sol.

Colligative properties \propto Net molality

(1) for KCl Net molality = $0.1 \times 2 = 0.2$

(2) for Glucose Net molality = $0.1 \times 1 = 0.1$

(3) for $\text{Al}_2(\text{SO}_4)_3$ Net molality = $0.1 \times 5 = 0.5$

(4) for K_2SO_4 Net molality = $0.1 \times 3 = 0.3$

Q.53 When 22.4 litres of $\text{H}_2(\text{g})$ is mixed with 11.2 litres of $\text{Cl}_2(\text{g})$, each at S.T.P., the moles of $\text{HCl}(\text{g})$ formed is equal to:

(1) 1 mole of $\text{HCl}(\text{g})$ (2) 2 mole of $\text{HCl}(\text{g})$

(3) 0.5 mol of $\text{HCl}(\text{g})$ (4) 1.5 mol of $\text{HCl}(\text{g})$

Ans. [1]

Sol.

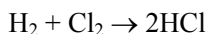

$$n_{\text{H}_2} = \frac{22.4}{22.4} = 1; n_{\text{Cl}_2} = \frac{11.2}{22.4} = \frac{1}{2}$$

\therefore To find L.R.

$$\begin{array}{cc} \text{H}_2 & \text{Cl}_2 \\ \frac{1}{1} & \frac{\left(\frac{1}{2}\right)}{1} = \frac{1}{2} \end{array}$$

\therefore Cl_2 is L.R.

& by stoichiometric ratio

$$\frac{n_{\text{HCl}}}{2} = \frac{n_{\text{Cl}_2}}{1}$$

$$n_{\text{HCl}} = 2 \times \frac{1}{2} = 1 \text{ mol.}$$

Q.54 When 0.1 mol MnO_4^{2-} is oxidized the quantity of electricity required to completely oxidize MnO_4^{2-} to MnO_4^- is:

(1) 96500 C

(2) 2×96500 C

(3) 9650 C

(4) 96.50 C

Ans. [3]

Sol.

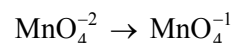

Oxidation no. +6 +7

\therefore change in oxidation number no = 1

So equivalent = mole \times v.f

= 0.1×1

= 0.1

\therefore Charge = $0.1 \times F$

= 0.1×96500

= 9650 C

Q.55 Using the Gibbs energy change, $\Delta G^\circ = +63.3$ kJ, for the following reaction,



The K_{sp} of $\text{Ag}_2\text{CO}_3(\text{s})$ in water at 25°C is:

($R = 8.314 \text{ J K}^{-1} \text{ mol}^{-1}$)

(1) 3.2×10^{-26}

(2) 8.0×10^{-12}

(3) 2.9×10^{-3}

(4) 7.9×10^{-2}

Ans. [2]

$$\Delta G^\circ = -2.303 RT \log K_{sp}$$

$$63.3 \times 1000 = -2.303 \times 8.314 \times 298 \times \log K_{sp}$$

$$\log K_{sp} = \frac{-63.3 \times 1000}{2.303 \times 8.314 \times 298}$$

$$\log K_{sp} = -11.09$$

$$\therefore K_{sp} = \text{anti log} (-11.09)$$

$$K_{sp} = 8.0 \times 10^{-12}$$

Q.56 The weight of silver (at. wt. = 108) displaced by a quantity of electricity which displaces 5600 mL of O₂ at STP will be:

- (1) 5.4 g (2) 10.8 g
 (3) 54.0 g (4) 108.0 g

Ans. [4]

Sol.

Equivalent volume of O₂ is 5.6 lit

\therefore 5.6 lit of O₂ means 1 equivalent of oxygen

& 1 equivalent of any species is displaced by 1 faraday charge

& \therefore 1 equivalent i.e. 108g of Ag is deposited by 1 faraday of charge

Q.57 Which of the following statements is correct for the spontaneous adsorption of a gas?

- (1) ΔS is negative and, therefore, ΔH should be highly positive.
 (2) ΔS is negative and therefore, ΔH should be highly negative
 (3) ΔS is positive and, therefore, ΔH should be negative
 (4) ΔS is positive and, therefore, ΔH should also be highly positive.

Ans. [2]

Sol.



\therefore As $\Delta n_g < 0$; then, $\Delta S < 0$

but $\Delta H < 0$ because process of adsorption is always exothermic

$\therefore \Delta S < 0$ & $\Delta H < 0$

& for spontaneous process

$$\Delta G < 0$$

Therefore: $|\Delta S| < |\Delta H|$

Q.58 For the reversible reaction:

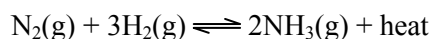

The equilibrium shifts in forward direction:

- (1) by increasing the concentration of NH₃(g)
 (2) by decreasing the pressure
 (3) by decreasing the concentrations of N₂(g) and H₂(g)
 (4) by increasing pressure and decreasing temperature

Ans. [4]

Sol.

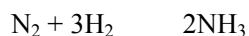

it is an exothermic reaction so decreasing temperature \rightleftharpoons is favorable because

$$\text{dissociation (x)} \propto \frac{1}{T}$$

$$\& \text{dissociation } x \propto \left(\frac{1}{P}\right)^{\frac{-2}{2}}$$

$$\therefore x \propto P$$

So increasing pressure is favorable for forward reaction

Q.59 For the reaction:

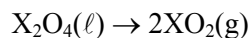

$$\Delta U = 2.1 \text{ k cal}, \Delta S = 20 \text{ cal K}^{-1} \text{ at } 300 \text{ K}$$

Hence, ΔG is:

$$(1) 2.7 \text{ k cal} \quad (2) -2.7 \text{ k cal}$$

$$(3) 9.3 \text{ k cal} \quad (4) -9.3 \text{ k cal}$$

Ans. [2]

Sol.

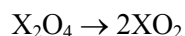

$$(\ell) \quad (g) \quad \Delta n_g = 2 - 0$$

$$\Delta n_g = 2$$

$$\Delta G = \Delta H - T\Delta S$$

So first of all we will calculate ΔH

$$\Delta H = \Delta U + \Delta n_g RT$$

$$\Delta H = 2.1 + (2) \times \frac{2}{1000} \times 300$$

$$\Delta H = 3.3 \text{ kcal}$$

Now

$$\Delta G = \Delta H - T\Delta S$$

$$= 3.3 - 300 \times \frac{20}{1000} \text{ (in kcal)}$$

$$= -2.7 \text{ kcal}$$

Q.60 For a given exothermic reaction, K_p and K'_p are the equilibrium constant at temperatures T_1 and T_2 , respectively. Assuming that heat of reaction is constant in temperature range between T_1 and T_2 , it is readily observed that-

$$(1) K_p > K'_p$$

$$(2) K_p < K'_p$$

$$(3) K_p = K'_p$$

$$(4) K_p = \frac{1}{K'_p}$$

Ans. [1]

Sol.

According to Vant Hoff equation

$$\log \frac{K'_p}{K_p} = \frac{\Delta H}{2.303R} \left[\frac{T_2 - T_1}{T_1 T_2} \right]$$

for exothermic reaction on increasing temperature equilibrium constant decreases

means $T_2 > T_1$ then $K'_p < K_p$

Q.61 Which of the following orders of ionic radii is correctly represented ?

$$(1) H^- > H^+ > H \quad (2) Na^+ > F^- > O^{2-}$$

$$(3) F^- > O^{2-} > Na^+ \quad (4) Al^{3+} > Mg^{2+} > N^{3-}$$

Ans. [Bonus]

Sol.

All option are incorrect order of ionic radius

Ionic radius $H^- > H^+ > H$

$$Na^+ > F^- > O^{2-}$$

$$F^- > O^{2-} > Na^+$$

$$Al^{+3} > Mg^{+2} > N^{-3}$$

Correct order of ionic radius are

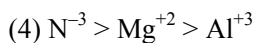
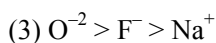
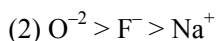
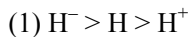

Q.62 1.0 g of magnesium is burnt with 0.56g O₂ in a closed vessel. Which reactant is left in excess and how much ?

(At. wt. Mg = 24; O = 16)



Ans. [1]

Sol.

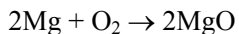

$$n_{Mg} = \frac{1}{24} \cong 0.042 \text{ \& } n_{O_2} = \frac{0.56}{32} = 0.0175$$

To find L.R.



$$\frac{0.042}{2} = 0.021 \qquad \frac{0.0175}{1} = 0.0175$$

∴ O₂ is LR & Mg is in excess

$$\begin{aligned} \text{Now } n_{Mg, \text{ reacted}} &= 0.0175 \times 2 \\ &= 0.035 \end{aligned}$$

$$\therefore n_{Mg, \text{ unreacted}} = 0.007$$

$$\begin{aligned} \therefore n_{Mg, \text{ remained}} &= 0.007 \times 27 \\ &= 0.16g \end{aligned}$$

Q.63 The pair of compounds that can exist together is:



Ans. [3]

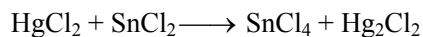
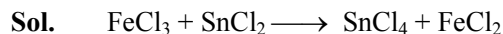

OA RA



OA RA

FeCl_2 and SnCl_2 pair can exist together because FeCl_2 and SnCl_2 both are act as reducing agent.

Q.64 Be^{2+} is isoelectronic with which of the following ions ?

- (1) H^+ (2) Li^+ (3) Na^+ (4) Mg^{2+}

Ans. [2]

Sol. Isoelectronic species have same number of total electron

Be^{+2} and Li^+ contain two electron

Q.65 Which of the following molecules has the maximum dipole moment ?

- (1) CO_2 (2) CH_4 (3) NH_3 (4) NF_3

Ans. [3]

Sol.

$$\mu = \frac{:\text{NH}_3}{\mu \neq 0} > \frac{\text{CH}_4 = \text{CO}_2}{\mu = 0}$$

$$\mu = \ddot{\text{N}}\text{H}_3 : > :\text{NF}_3$$

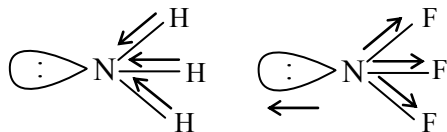

← ←
atomic dipole
&
bond dipole
are in same
direction

← →
atomic dipole
&
bond dipole
are in opposite
direction

Q.66 Which one of the following species has plane triangular shape ?

- (1) N_3^- (2) NO_3^- (3) NO_2^- (4) CO_2

Ans. [2]

Sol.

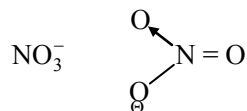

Hybridisation : sp^2

shape :- plane triangular

Q.67 Acidity of diprotic acids in aqueous solutions increases in the order:

- (1) $\text{H}_2\text{S} < \text{H}_2\text{Se} < \text{H}_2\text{Te}$
(2) $\text{H}_2\text{Se} < \text{H}_2\text{S} < \text{H}_2\text{Te}$
(3) $\text{H}_2\text{Te} < \text{H}_2\text{S} < \text{H}_2\text{Se}$
(4) $\text{H}_2\text{Se} < \text{H}_2\text{Te} < \text{H}_2\text{S}$

Ans. [1]

Sol.

Acidic strength of chalcogen hydride increase down the group because bond length increases and dissociation energy decreases

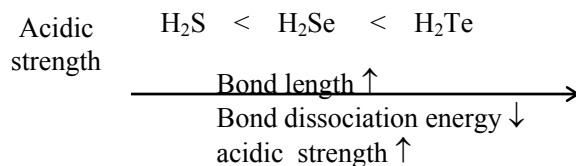

Sol.

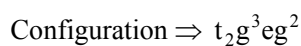
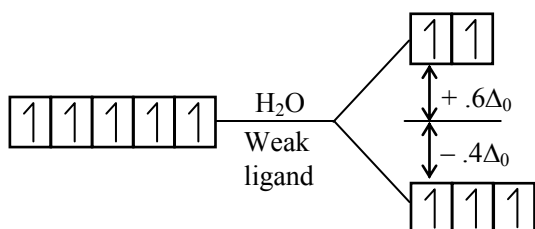
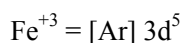
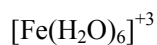

$$\text{C.F.S.E.} = (-.4\Delta_0 \times 3) + (+.6\Delta_0 \times 2)$$

$$= -1.2\Delta_0 + 1.2\Delta_0$$

$$\text{C.F.S.E} = 0 \Delta_0$$

Q.73 Magnetic moment 2.83 BM is given by which of the following ions?

(At. no. Ti = 22, Cr = 24, Mn = 25, Ni = 28)

- (1) Ti^{3+}
- (2) Ni^{2+}
- (3) Cr^{3+}
- (4) Mn^{2+}

Ans. [2]

Sol.

$$\mu = \sqrt{n(n+2)} \text{ B.M.}$$

$$\mu = 2.83 \therefore n = 2$$

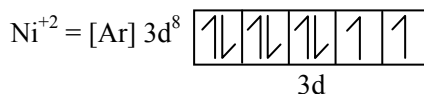

$$n = 2$$

$$\mu = \sqrt{n(n+2)}$$

$$\mu = \sqrt{2(2+2)}$$

$$\mu = \sqrt{8}$$

$$\mu = 2.83$$

Q.74 Which of the following complexes is used to be as an anticancer agent ?

- (1) mer - $[\text{Co}(\text{NH}_3)_3 \text{Cl}_3]$
- (2) cis - $[\text{PtCl}_2(\text{NH}_3)_2]$
- (3) cis - $\text{K}_2[\text{PtCl}_2\text{Br}_2]$
- (4) Na_2CoCl_4

Ans. [2]

Sol.

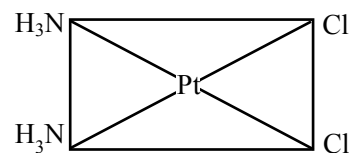

cis-platin used as anticancer agent

Q.75 Reason of lanthanoid contraction is :

- (1) Negligible screening effect of 'f' orbitals
- (2) Increasing nuclear charge
- (3) Decreasing nuclear charge
- (4) Decreasing screening effect

Ans. [1]

Sol.

Lanthanoid contraction is due to negligible shielding effect of f-orbitals.

Order of shielding effect = $s > p > d > f$

Q.76 In the following reaction, the product (A) is :

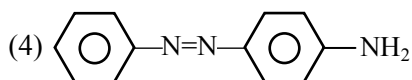
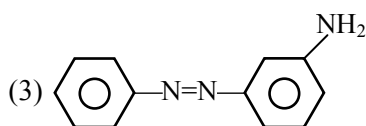
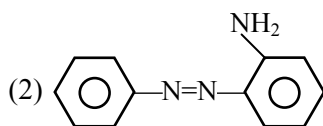
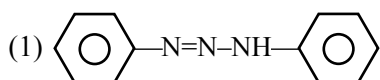
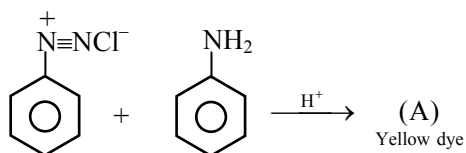

Ans. [4]

Sol.

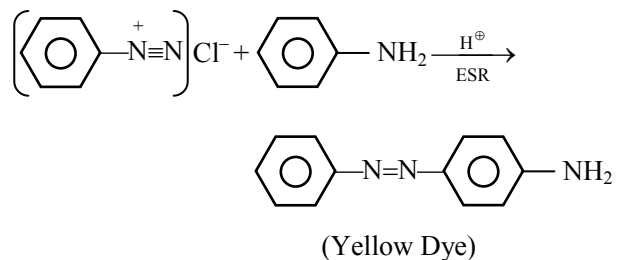

Q.77 Which of the following will be most stable diazonium salt $RN_2^+X^-$?

- (1) $CH_3N_2^+X^-$ (2) $C_6H_5N_2^+X^-$
(3) $CH_3CH_2N_2^+X^-$ (4) $C_6H_5CH_2N_2^+X^-$

Ans. [2]

Sol. c1ccc(cc1)[N+]#N.[Cl-] is most stable because benzene ring is involve in resonance.

Q.78 D(+) glucose reacts with hydroxyl amine and yields an oxime. The structure of the oxime would be :

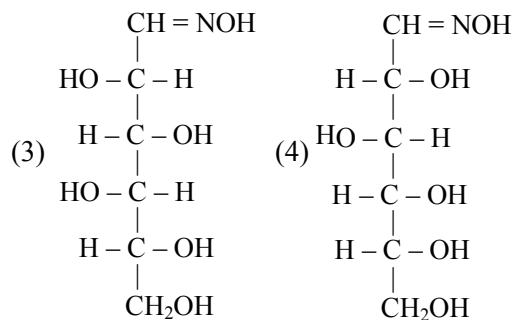
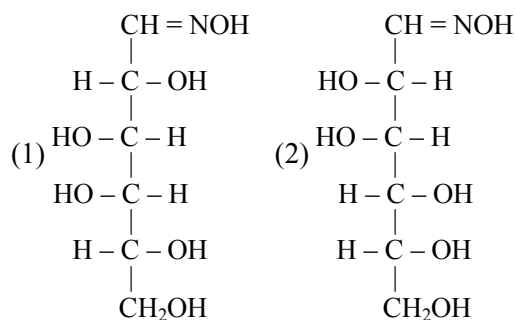

Ans. [4]

Sol.

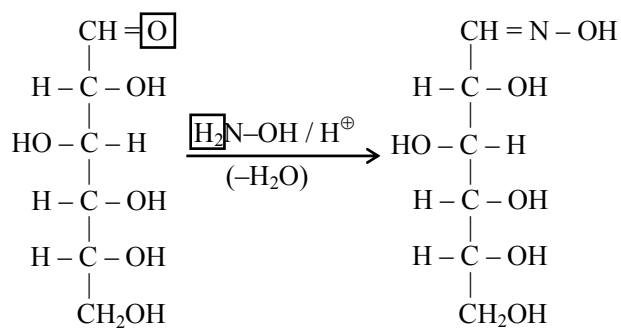

D(+) glucose

D(+) glucoxime

Q.79 Which of the following hormones is produced under the condition of stress which stimulates glycogenolysis in the liver of human beings?

- (1) Thyroxin (2) Insulin
 (3) Adrenaline (4) Estradiol

Ans. [3]

Sol.

Adrenaline is produced under the condition of stress which stimulates glycogenolysis in the liver of human beings.

Q.80 Which one of the following is an example of a thermosetting polymer ?

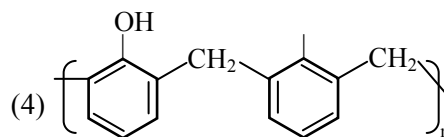
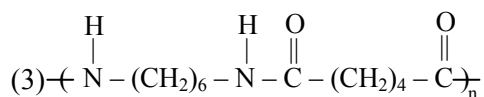
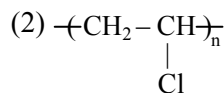
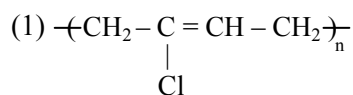

Ans. [4]

Sol.

Bakelite is a thermosetting polymer which have following structure.

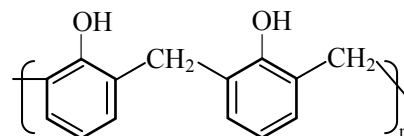

Q.81 Which of the following organic compounds polymerizes to form the polyester Dacron?

- (1) Propylene and para HO – (C₆H₄) – OH
- (2) Benzoic acid and ethanol
- (3) Terephthalic acid and ethylene glycol
- (4) Benzoic acid and para HO – (C₆H₄) – OH

Ans. [3]

Sol.

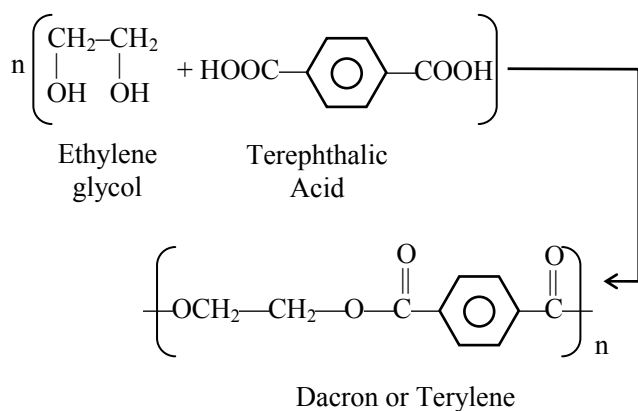

Q.82 Which one of the following is not a common component of Photochemical Smog?

- (1) Ozone
- (2) Acrolein
- (3) Peroxyacetyl nitrate
- (4) Chlorofluorocarbons

Ans. [4]

Sol.

Ozone, Acrolein & PAN are the common components of photo chemical smog. So CFC (Freon) is the answer.

Q.83 In the Kjeldahl's method for estimation of nitrogen present in a soil sample, ammonia evolved from 0.75 g of sample neutralized 10 mL of 1M H₂SO₄. The percentage of nitrogen in the soil is :

- (1) 37.33
- (2) 45.33
- (3) 35.33
- (4) 43.33

Ans. [1]

Sol.

Kjeldahl's method

1 M of 10 ml H₂SO₄ = 1M of 20 ml NH₃.
1000 ml of 1M ammonia contains 14 gm nitrogen.

20 ml of 1M ammonia contains $\frac{14 \times 20}{1000}$ gm nitrogen

$$\% \text{ of nitrogen} = \frac{14 \times 20 \times 100}{1000 \times 0.75} = 37.33\%$$

Q.84 What products are formed when the following compound is treated with Br₂ in the presence of FeBr₃?

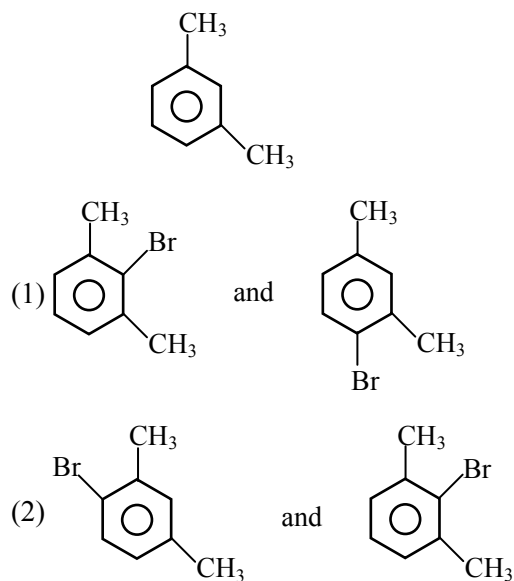

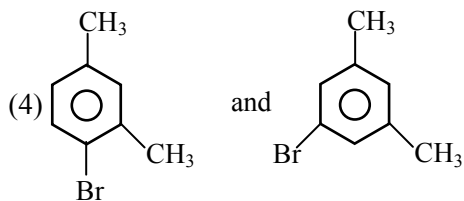
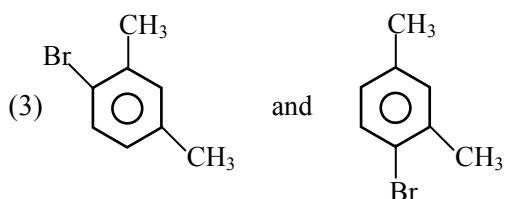

Ans. [3]

Sol.

Both methyl are o/p – directing groups and at para-position steric hinderance is not applicable therefore 1-bromo-2,4-dimethyl is **exclusive** product.

Remember 2-bromo-1,3-dimethyl benzene is obtained less than 1%.

Hence options (3) is the most appropriate answer.

Q.85 Which of the following compounds will undergo racemisation when solution of KOH hydrolyses?

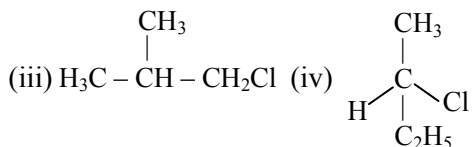
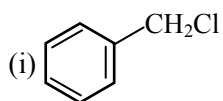

(1) (i) and (ii) (2) (ii) and (iv)

(3) (iii) and (iv) (4) (i) and (iv)

Ans. [Bonus]

Sol. Wrong framing of questions.

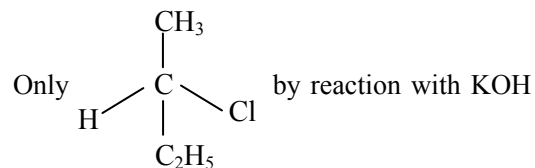

undergo reaceimisation. But suitable option is absent therefore BONUS.

Q.86 Among the following sets of reactants which one produces anisole ?

(1) CH_3CHO ; RMgX

(2) $\text{C}_6\text{H}_5\text{OH}$; NaOH ; CH_3I

(3) $\text{C}_6\text{H}_5\text{OH}$; neutral FeCl_3

(4) $\text{C}_6\text{H}_5-\text{CH}_3$; CH_3COCl ; AlCl_3

Ans. [2]

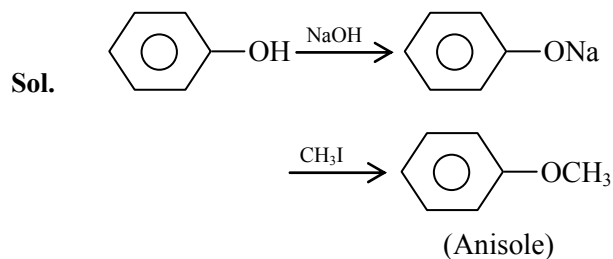

Q.87 Which of the following will not be soluble in sodium hydrogen carbonate ?

(1) 2, 4, 6 – trinitrophenol

(2) Benzoic acid

(3) o – Nitrophenol

(4) Benzenesulphonic acid

Ans. [3]

Sol.

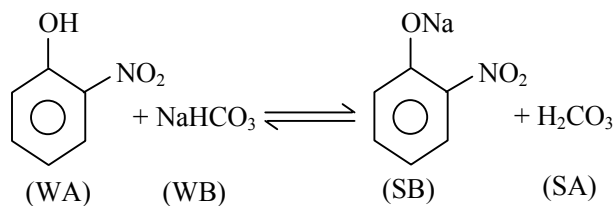

Therefore this reaction is not possible in forward direction.

Q.88 Which one is most reactive towards Nucleophilic addition reaction ?

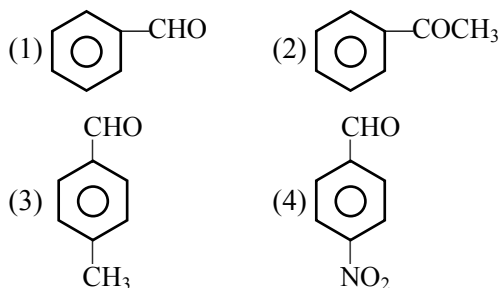

Ans. [4]

Sol.

$$\text{N.A.R.} \propto \oplus \text{ve charge on } sp^2 \text{ carbon} \propto \frac{-I, -M}{+I, +M}$$

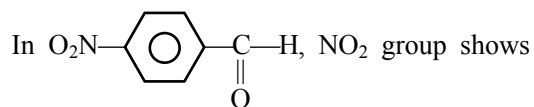

-M effect so it is max. reactive.

Q.89 Identity Z in the sequence of reactions :

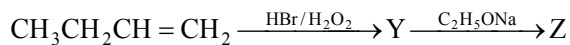

- (1) CH₃ - (CH₂)₃ - O - CH₂CH₃
- (2) (CH₃)₂CH₂ - O - CH₂CH₃
- (3) CH₃(CH₂)₄ - O - CH₃
- (4) CH₃CH₂ - CH(CH₃) - O - CH₂CH₃

Ans. [1]

Sol.

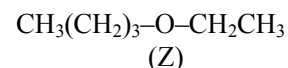
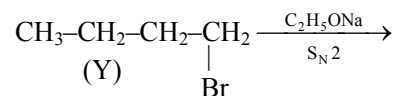
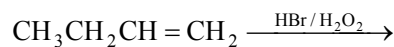

Q.90 Which of the following organic compounds has same hybridization as its combustion product - (CO₂)?

- (1) Ethane
- (2) Ethyne
- (3) Ethene
- (4) Ethanol

Ans. [2]

Sol.

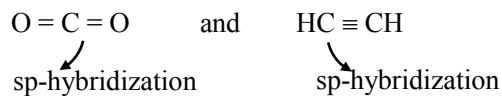

Q.91 Which one of the following shows isogamy with non-flagellated gametes ?

- (1) *Sargassum* (2) *Ectocarpus*
(3) *Ulothrix* (4) *Spirogyra*

Ans. [4]

Sol.

In spirogyra, non-motile gametes are present, both of the gamete are morphologically same.

Q.92 Five kingdom system of classification suggested by R.H. Whittaker is not based on -

- (1) Presence or absence of a well defined nucleus
(2) Mode of reproduction
(3) Mode of nutrition
(4) Complexity of body organisation

Ans. [1]

Sol.

Whittaker five kingdom classification is mainly based on following character

1. Cell structure
2. Thallus organization
3. Mode of Nutrition
4. Mode of reproduction
5. Phylogenetic relationship

Q.93 Which one of the following fungi contains hallucinogens ?

- (1) *Morchella esculenta*
(2) *Amantia muscaria*
(3) *Neurospora* sp.
(4) *Ustilago* sp.

Ans. [2]

Sol. *Amanita muscaria* is a hallucinogenic fungi *Amanita muscaria* have pschycoactive agent muscimol.

Q.94 Archaeobacteria differ from eubacteria in -

- (1) Cell membrane structure
(2) Mode of nutrition
(3) Cell shape
(4) Mode of reproduction

Ans. [1]

Sol.

In archaeobacteria cell membrane is made up of single layer of branched chain lipid molecule, while in eubacteria it is made up of unbranched phospholipids bilayer

Q.95 Which one of the following is **wrong** about *Chara* ?

- (1) Upper oogonium and lower round antheridium
(2) Globule and nuclue present on the same plant
(3) Upper antheridium and lower oogonium
(4) Globule is male reproductive structure

Ans. [3]

Sol. Anthredium is present towards lower side and oogonium present towards the upper surface on same plant.

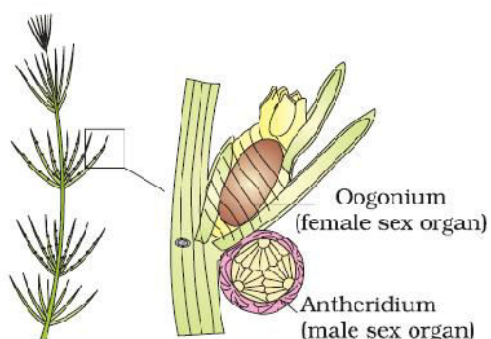

Q.96 Which of the following is responsible for peat formation ?

- (1) *Marchantia* (2) *Riccia*
 (3) *Funaria* (4) *Sphagnum*

Ans. [4]

Sol.

Peat is formed by sphagnum.

Q.97 Placenta and pericarp are both edible portions in -

- (1) Apple (2) Banana
 (3) Tomato (4) Potato

Ans. [3]

Sol.

Placenta and pericarp both are edible in tomato.

Q.98 When the margins of sepals or petals overlap one another without any particular direction, the condition is termed as -

- (1) Vexillary (2) Imbricate
 (3) Twisted (4) Valvate

Ans. [2]

Sol.

In Imbricate aestivation margins of sepal or petal overlap one another without any particular direction.

Q.99 You are given a fairly old piece of dicot stem and a dicot root. Which of the following anatomical structures will you use to distinguish between the two ?

- (1) Secondary xylem
 (2) Secondary phloem
 (3) Protoxylem
 (4) Cortical cells

Ans. [3]

Sol.

On the basis of position of Protoxylem, root can be differentiated from shoot. In root xylem is exarch i.e. protoxylem is towards periphery while in shoot xylem is endarch i.e. protoxylem is towards centre.

Q.100 Which one of the following statements is **correct** ?

- (1) The seed in grasses is not endospermic
 (2) Mango is a parthenocarpic fruit
 (3) A proteinaceous aleurone layer is present in maize grain
 (4) A sterile pistil is called a staminode

Ans. [3]

Sol.

Maize seed is endospermic seed, having outermost layer of endosperm aleuron, which is rich in protein.

Q.101 Tracheids differ from other tracheary elements in -

- (1) having casparian strips
- (2) being imperforate
- (3) lacking nucleus
- (4) being lignified

Ans. [2]

Sol.

Tracheids have pitted end wall while vessels are perforated end wall.

Q.102 An example of edible underground stem is -

- (1) Carrot
- (2) Groundnut
- (3) Sweet potato
- (4) Potato

Ans. [4]

Sol.

Potato tuber is edible underground stem.

Q.103 Which structures perform the function of mitochondria in bacteria ?

- (1) Nucleoid
- (2) Ribosomes
- (3) Cell wall
- (4) Mesosomes

Ans. [4]

Sol.

Mesosomes are involved in aerobic respiration in bacteria.

Q.104 The solid linear cytoskeletal elements having a diameter of 6 nm and made up of a single type of monomer are known as -

- (1) Microtubules
- (2) Microfilaments
- (3) Intermediate filaments
- (4) Lamins

Ans. [2]

Sol. Microfilament are made up of 2 molecules of 6 nm actin protein. Microtubule are 25 nm hollow tube like structure while intermediate filament are 10 nm and lamins are nuclear proteins.

Q.105 The osmotic expansion of a cell kept in water is chiefly regulated by -

- (1) Mitochondria
- (2) Vacuoles
- (3) Plastids
- (4) Ribosomes

Ans. [2]

Sol.

Vacuole is involved in osmoregulation in plant cell.

Q.106 During which phase(s) of cell cycle, amount of DNA in a cell remains of 4C level if the initial amount is denoted as 2C ?

- (1) G₀ and G₁
- (2) G₁ and S
- (3) Only G₂
- (4) G₂ and M

Ans. [4]

Sol.

G₂ and M in 'S' phase DNA duplication occur. This leads to increase in 2C concentration to 4C concentration, which decreases to 2C at the end of M phase.

Q.107 Match the following and select the **correct** answer :

- | | |
|-----------------|-----------------------------------|
| (a) Centriole | (i) Infoldings in mitochondria |
| (b) Chlorophyll | (ii) Thylakoids |
| (c) Cristae | (iii) Nucleic acids |
| (d) Ribozymes | (iv) Basal body cilia or flagella |

- | | (a) | (b) | (c) | (d) |
|-----|------|-------|------|-------|
| (1) | (iv) | (ii) | (i) | (iii) |
| (2) | (i) | (ii) | (iv) | (iii) |
| (3) | (i) | (iii) | (ii) | (iv) |
| (4) | (iv) | (iii) | (i) | (ii) |

Ans. [1]

- Sol.**
- | | |
|-----------------|-----------------------------------|
| (a) Centriole | (iv) Basal body cilia or flagella |
| (b) Chlorophyll | (ii) Thylakoids |
| (c) Cristae | (i) Infoldings in mitochondria |
| (d) Ribozymes | (iii) Nucleic acids |

Q.108 Dr. F. Went noted that if coleoptile tips were removed and placed on agar for one hour, the agar would produce a bending when placed on one side of freshly-cut coleoptile stumps. of what significance is this experiment ?

- (1) It made possible the isolation and exact identification of auxin
- (2) It is the basis for quantitative determination of small amounts of growth-promoting substances
- (3) It supports the hypothesis that IAA is auxin
- (4) It demonstrated polar movement of auxins

Ans. [4]

Sol.

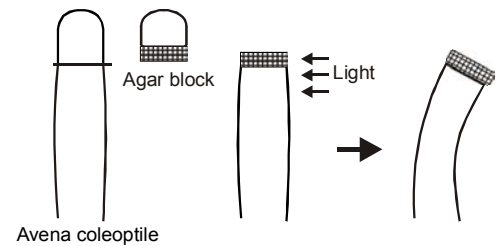

Experiment-1

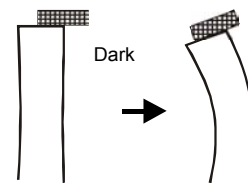

Experiment-2

*This experiment of f.w. Went proves that transport of auxin is polar and basipetal.

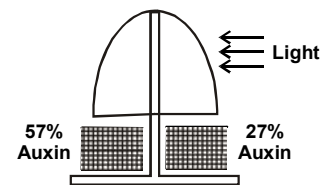

Experiment-3

F.W. went have performed 3 main experiment given in diagrams. On the basis of these 3 experiments he gave 3 conclusions respectively –

- (1) Growth is directly proportional to conc. of auxin in Agar block. On basis of Exp.-1 (in fig.)
- (2) Transport of auxin is polar and basipetal. On basis of Exp.-2 (in fig.)
- (3) High conc. of auxin towards dark side (57%) and less auxin conc. towards light side (27%) rest 16% is photooxidised. On basis of Exp.-3. (in fig.)

*In given question Exp.-2 is asked.

Q.109 Deficiency symptoms of nitrogen and potassium are visible first in -

- (1) Senescent leaves
- (2) Young leaves
- (3) Roots
- (4) Bunds

Ans. [1]

Sol.

Nitrogen and potassium are mobile elements. Deficiency symptoms of mobile elements first appears in older or mature plant parts as older parts acts as source of mobile elements.

Q.110 In which one of the following processes CO₂ is not released ?

- (1) Aerobic respiration in plants
- (2) Aerobic respiration in animals
- (3) Alcoholic fermentation
- (4) Lactate fermentation

Ans. [4]

Sol.

Lactic acid fermentation.

Biochemical reaction

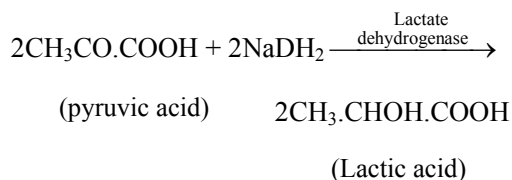

Q.111 Anoxygenic photosynthesis is characteristic of-

- (1) *Rhodospirillum*
- (2) *Spirogyra*
- (3) *Chlamydomonas*
- (4) *Ulva*

Ans. [1]

Sol.

Rhodospirillum in non-oxygenic photosynthetic bacteria.

Q.112 A few normal seedlings of tomato were kept in a dark room. After a few days they were found to have become white-coloured like albinos. Which of the following terms will you use to describe them ?

- (1) Mutated (2) Embolised
- (3) Etiolated (4) Defoliated

Ans. [3]

Sol.

Etiolation like of chlorophyll pigments due to deficiency of sunlight. So plant get etiolated.

Q.113 Which one of the following growth regulators is known as 'stress hormone' ?

- (1) Abscissic acid (2) Ethylene
(3) GA₃ (4) Indole acetic acid

Ans. [1]

Sol.

Abscissic acid (ABA) is considered as "Stress hormone" of plants as it protects plants from various kinds of stresses.

Q.114 Geitonogamy involves -

- (1) Fertilization of a flower by the pollen from another flower of the same plant
(2) Fertilization of a flower by the pollen from the same flower
(3) Fertilization of a flower by the pollen from a flower of another plant in the same population
(4) Fertilization of a flower by the pollen from a flower of another plant belonging to a distant population

Ans. [1]

Sol.

Geitonogamy – pollination between two flowers of same plant.

Q.115 Male gametophyte with least number of cells is present in -

- (1) *Pteris* (2) *Funaria*
(3) *Lilium* (4) *Pinus*

Ans. [3]

Sol.

Most reduced male gametophyte or minimum no. of cell in male gametophyte is present in angiosperm (3 celled male gametophyte). *Lilium* is angiosperm.

Q.116 An aggregate fruit is one which develops from-

- (1) Multicarpellary syncarpous gynoecium
(2) Multicarpellary apocarpus gynoecium
(3) Complete inflorescence
(4) Multicarpellary superior ovary

Ans. [2]

Sol.

Aggregate fruit is developed from multicarpellary apocarpous gynoecium.

Q.117 Pollen tablets are available in the market for -

- (1) In vitro fertilization
(2) Breeding programmes
(3) Supplementing food
(4) *Ex situ* conservation

Ans. [3]

Sol.

Pollen tablets and syrups are used as supplementary food as rich in nutrients.

- Q.118** Function of filiform apparatus is to -
- (1) Recognize the suitable pollen at stigma
 - (2) Stimulate division of generative cell
 - (3) Produce nectar
 - (4) Guide the entry of pollen tube

Ans. [4]

Sol.

Filiform apparatus present in synergid cells helps in guiding pollen tube into embryo sac.

- Q.119** Non-albuminous seed is produced in -
- | | |
|-----------|------------|
| (1) Maize | (2) Castor |
| (3) Wheat | (4) Pea |

Ans. [4]

Sol.

Pea is a non-endospermic/Non-albuminous seed, as endosperm consumed during embryo development.

- Q.120** Which of the following shows coiled RNA strand and capsomeres ?
- (1) Polio virus
 - (2) Tobacco mosaic virus
 - (3) Measles virus
 - (4) Retrovirus

Ans. [2]

Sol.

Tobacco mosaic virus has single stranded coiled RNA and protein capsid.

- Q.121** Which one of the following is **wrongly** matched ?
- (1) Transcription – Writing information from DNA to t-RNA
 - (2) Translation – Using information in m-RNA to make protein
 - (3) Repressor protein – Binds to operator to stop enzyme synthesis
 - (4) Operon – Structural genes, operator and promoter

Ans. [1]

Sol. Transcription is writing information from DNA to m-RAN not DNA from m-RNA.

Q.122 Transformation was discovered by -

- (1) Meselson and Stahl
- (2) Hershey and Chase
- (3) Griffith
- (4) Watson and Crick

Ans. [3]

Sol.

Transformation was discovered by Griffith in Pneumococcus pneumonie bacteria.

Q.123 Fruit colour in squash is an example of -

- (1) Recessive epistasis
- (2) Dominant epistasis
- (3) Complementary genes
- (4) Inhibitory genes

Ans. [2]

Sol. F₂ phenotype ratio in this gene interaction is 12 : 3 : 1 which represent dominant epistasis.

Q.124 Viruses have -

- (1) DNA enclosed in a protein coat
- (2) Prokaryotic nucleus
- (3) Single chromosome
- (4) Both DNA and RNA

Ans. [1]

Sol.

Viruses are having either RNA or DNA encapsulated by protein capsid.

Q.125 The first human hormone produced by recombinant DNA technology is -

- (1) Insulin
- (2) Estrogen
- (3) Thyroxin
- (4) Progesterone

Ans. [1]

Sol.

First human hormone produced by recombinant technology is insulin by Eli Lilly an American company in 1983.

Q.126 An analysis of chromosomal DNA using the Southern hybridization technique **does not** use-

- (1) Electrophoresis
- (2) Blotting
- (3) Autoradiography
- (4) PCR

Ans. [4]

Sol. **CP Students may find this concept in CP Ex : Sheet: [Chapter : Genetics, Page No. 53]**

This is a technique of detecting DNA by using a DNA probe in this technique DNA is separated by gel electrophoresis and then transferred from the gel to membrane by blotting. The DNA was detected from membrane with a DNA probe to complementary bind to DNA the probe was labelled by radio active ³²P the labeled probes hybridise target DNA present in blot this probe is detect by auto radiography. So PCR is not included in it.

Q.127 In vitro clonal propagation in plants is characterized by -

- (1) PCR and RAPD
- (2) Northern blotting
- (3) Electrophoresis and HPLC
- (4) Microscopy

Ans. [1]

- | | (a) | (b) | (c) | (d) |
|-----|-------|------|-------|-------|
| (1) | (i) | (ii) | (iii) | (iv) |
| (2) | (iv) | (i) | (iii) | (ii) |
| (3) | (iii) | (ii) | (iv) | (i) |
| (4) | (ii) | (i) | (iv) | (iii) |

Ans. [4]

Sol. This is a direct theory based question.

Q.133 A species facing extremely high risk of extinction in the immediate future is called -

- (1) Vulnerable
- (2) Endemic
- (3) Critically Endangered
- (4) Extinct

Ans. [3]

Sol.

Critically endangered species means species facing an extremely high risk of extinction in wild in immediate future.

Q.134 The zone of atmosphere in which the ozone layer is present is called -

- | | |
|------------------|-----------------|
| (1) Ionosphere | (2) Mesosphere |
| (3) Stratosphere | (4) Troposphere |

Ans. [3]

Sol. Ozone is present in stratosphere.

Q.135 The organization which publishes the Red List of species is -

- | | |
|-----------|----------|
| (1) ICFRE | (2) IUCN |
| (3) UNEP | (4) WWF |

Ans. [2]

Sol.

IUCN publishes red data book.

Q.136 Select the Taxon mentioned that represent both marine and fresh water species -

- | | |
|---------------------|----------------|
| (1) Echinoderms | (2) Ctenophora |
| (3) Cephalochordata | (4) Cnidaria |

Ans. [4]

Sol.

Phylum cnidaria includes both fresh water and marine species where as Echinoderms, Ctenophores and Cephalochordates are exclusively marine.

Q.137 Which one of the following living organisms completely *lacks* a cell wall ?

- (1) Cyanobacteria
- (2) Sea-fan (*Gorgonia*)
- (3) *Saccharomyces*
- (4) Blue-green algae

Ans. [2]

Sol.

Sea fan is an animal belonging to phylum coelenterata, that does not have cell wall where as cyanobacteria, saccharomyces (fungus) and blue-green algae have cell wall.

Q.138 *Planaria* possesses high capacity of -

- (1) Metamorphosis
- (2) Regeneration
- (3) Alternation of generation
- (4) Bioluminescence

Ans. [2]

Sol.

Planaria (*Dugesia*) has the power of regeneration (*morphallaxis*) means it can regenerate the entire body with lost body part.

(Translation of option (2) in Hindi is wrong, so we have considered English option)

Q.139 A marine cartilaginous fish that can produce electric current is -

- (1) *Pristis* (2) *Torpedo*
- (3) *Trygon* (4) *Scoliodon*

Ans. [2]

Sol.

Torpedo (electric ray) produces electric current with the help of specialized muscles. Where as *Pristis* is Saw fish, *Trygon* is Sting ray, *Scoliodon* is Dog fish.

Q.140 Choose the correctly matched pair -

- (1) Tendon – Specialized connective tissue
- (2) Adipose tissue – Dense connective tissue
- (3) Areolar tissue – Loose connective tissue
- (4) Cartilage – Loose connective tissue

Ans. [3]

Sol.

Areolar tissue is the kind of loose connective tissue. Such type of tissues have less connective tissue cell and more intercellular space.

Q.141 Choose the correctly matched pair -

- (1) Inner lining of salivary ducts – Ciliated epithelium
- (2) Moist surface of buccal cavity – Glandular epithelium
- (3) Tubular parts of nephrons –Cuboidal epithelium
- (4) Inner surface of bronchioles – squamous epithelium

Ans. [3]

Sol.

Tubular part of nephron and mostly duct of glands are lined by cuboidal epithelium.

Q.142 In 'S' phase of the cell cycle -

- (1) Amount of DNA-doubles in each cell
- (2) Amount of DNA remains same in each cell
- (3) Chromosome number is increased
- (4) Amount of DNA is reduced to half in each cell

Ans. [1]

Sol.

DNA duplication occur in S phase.

Q.143 The motile bacteria are able to move by -

- (1) Fimbriae (2) Flagella
- (3) Cilia (4) Pili

Ans. [2]

Sol.

Motile bacteria show flagellary movement.

Q.144 Select the option which is **not correct** with respect to enzyme action -

- (1) Substrate binds with enzyme at its active site
- (2) Addition of lot of succinate does not reverse the inhibition of succinic dehydrogenase by malonate
- (3) A non-competitive inhibitor binds the enzyme at a site distinct from that which binds the substrate
- (4) Malonate is a competitive inhibitor of succinic dehydrogenase

Ans. [2]

Sol.

Inhibition of enzyme succinic dehydrogenase by malonate is example of competitive reversible inhibition. So if substrate succinate concentration is increased, it will remove malonate from active site and reaction becomes normal, so succinate reverse the inhibition of succinic dehydrogenase.

Q.145 Which one of the following is a non-reducing carbohydrate?

- (1) Maltose
- (2) Sucrose
- (3) Lactose
- (4) Ribose 5-phosphate

Ans. [2]

Sol.

Sucrose is non reducing disaccharide.

Q.146 The enzyme recombinase is required at which stage of meiosis -

- (1) Pachytene (2) Zygotene
- (3) Diplotene (4) Diakinesis

Ans. [1]

Sol.

Recombinase enzyme is involved in process of crossing over which occur in pachytene stage.

Q.147 The initial step in the digestion of milk in humans is carried out by -

- (1) Lipase (2) Trypsin
- (3) Rennin (4) Pepsin

Ans. [3]

Sol.

Initial step in the digestion of milk is carried out by rennin. Because of rennin coagulates the milk in stomach.

Q.148 Fructose is absorbed into the blood through mucosa cells of intestine by the process called -

- (1) active transport
- (2) facilitated transport
- (3) simple diffusion
- (4) co-transport mechanism

Ans. [2]

Sol.

Absorption of fructose by blood through mucosa cell of intestine by facilitated transport because of in this type of absorption Na^+ is used.

Q.149 Approximately seventy percent of carbon-dioxide absorbed by the blood will be transported to the lungs -

- (1) as bicarbonate ions
- (2) in the form of dissolved gas molecules
- (3) by binding of R.B.C.
- (4) as carbamino-haemoglobin

Ans. [1]

Sol. 70 % of CO_2 is transported in the form of bicarbonate due to presence of carbonic anhydrase enzyme inside RBC.

Q.150 Person with blood group AB is considered as universal recipient because he has -

- (1) both A and B antigens on RBC but no antibodies in the plasma
- (2) both A and B antibodies in the plasma.
- (3) no antigen on RBC and no antibody in the plasma.
- (4) both A and B antigens in the plasma but no antibodies.

Ans. [1]

Sol.

AB blood group individual contain both antigen A and B on its surface it does not cause antigenesis by entry of A and B antigen.

Q.151 How do parasympathetic neural signals affect the working of the heart ?

- (1) Reduce both heart rate and cardiac output
- (2) Heart rate is increased without affecting the cardiac output
- (3) Both heart rate and cardiac output increase
- (4) Heart rate decreases but cardiac output increases.

Ans. [1]

Sol.

Parasympathetic nerve vagus reduces the heart rate, this in turn reduces the cardiac output also.

Q.152 Which of the following causes an increase in sodium reabsorption in the distal convoluted tubule -

- (1) Increase in aldosterone levels
- (2) Increase in antidiuretic hormone levels
- (3) Decrease in aldosterone levels
- (4) Decrease in antidiuretic hormone levels

Ans. [1]

Sol.

Aldosterone causes increase in Na^+ reabsorption from DCT by active process.

Q.153 Select the correct matching of the type of the joint with the example in human skeletal system -

Type of joint	Example
(1) Cartilaginous joint	between frontal and parietal
(2) Pivot joint	between third and fourth cervical vertebrae
(3) Hinge joint	between humerus and pectoral girdle
(4) Gliding joint	between carpals

Ans. [4]

Sol.

Gliding/plain synovial joint can be found in between carpals of hand.

Q.154 Stimulation of a muscle fiber by a motor neuron occurs at -

- (1) the neuromuscular junction
- (2) the transverse tubules
- (3) the myofibril
- (4) the sarcoplasmic reticulum

Ans. [1]

Sol.

During muscle contraction motor nerve secretes Acetylcholine neurotransmitter which goes on the muscle fibre through diffusion. Relation of motor nerve and muscle is called as neuromuscular junction.

Q.155 Injury localized to the hypothalamus would most likely disrupt -

- (1) short-term memory
- (2) co-ordination during locomotion
- (3) executive functions, such as decision making
- (4) regulation of body temperature

Ans. [4]

Sol.

Thermoregulation centre of body is present in hypothalamus of brain.

Q.156 Which one of the following statement is not correct ?

- (1) Retinal is the light absorbing portion of visual photopigments.
- (2) In retina the rods have the photo pigment rhodopsin while cones have three different photopigments
- (3) Retinal is derivative of Vitamin C
- (4) Rhodopsin is the purplish red protein present in rods only

Ans. [3]

Sol.

In this question **not correct** statement was asked. Retinal is derivative of vitamin 'A' not vitamin 'C'.

Q.157 Identify the hormone with its **correct** matching of source and function -

- (1) Oxytocin-posterior pituitary, growth and maintenance of mammary glands.
- (2) Melatonin-pineal gland, regulates the normal rhythm of sleep-wake cycle
- (3) Progesterone-corpora-luteum, stimulation of growth and activities of female secondary sex organs.
- (4) Atrial natriuretic factor-ventricular wall increases the blood pressure.

Ans. [2]

Sol.

Melatonin is released from pineal gland. Activity of pineal is regulated by light. Melatonin regulates diurnal rhythm.

Q.158 Fight-or-flight reaction cause activation of -

- (1) the parathyroid glands, leading to increased metabolic rate
- (2) the kidney, leading to suppression of renin-angiotensin-aldosterone pathway
- (3) the adrenal medulla, leading to increased secretion of epinephrine and norepinephrine
- (4) the pancreas leading to a reduction in the blood sugar levels

Ans. [3]

Sol.

During fight or flight reaction sympathetic neurons activate adrenal medulla to produce adrenaline & noradrenaline.

Q.159 The shared terminal duct of the reproductive and urinary system in the human male is -

- (1) Urethra (2) Ureter
- (3) Vas deferens (4) Vasa efferentia

Ans. [1]

Sol.

Q.160 The main function of mammalian corpus luteum is to produce -

- (1) estrogen only
- (2) progesterone
- (3) human chorionic gonadotropin
- (4) relaxin only

Ans. [2]

Sol. Corpus luteum secretes pregnancy hormone progesterone.

Q.161 Select the correct option describing gonadotropin activity in a normal pregnant female -

- (1) High level of FSH and LH stimulates the thickening of endometrium
- (2) High level of FSH and LH facilitate implantation of the embryo
- (3) High level of hCG stimulates the synthesis of estrogen and progesterone
- (4) High level of hCG stimulates the thickening of endometrium

Ans. [3]

Sol.

HCG is released by placenta which helps in sustaining the level of sex hormones to support pregnancy.

Q.162 Tubectomy is a method of sterilization in which-

- (1) small part of the fallopian tube is removed or tied up
- (2) ovaries are removed surgically
- (3) small part of vas deferens is removed or tied up
- (4) uterus is removed surgically

Ans. [1]

Sol.

Tubectomy is a method of female sterilisation.

Q.163 Which of the following is a hormone releasing Intra Uterine Device (IUD) ?

- (1) Multiload 375 (2) LNG-20
- (3) Cervical cap (4) Vault

Ans. [2]

Sol.

LNG-20 is a levonorgestrel releasing IUD.

Q.164 Assisted reproductive technology, IVF involves transfer of -

- (1) Ovum into the fallopian tube
- (2) Zygote into the fallopian tube
- (3) Zygote into the uterus
- (4) Embryo with 16 blastomeres into the fallopian tube

Ans. [2]

Sol.

Zygote intrafallopian transfer or ZIFT is the technique, which is referred in the questions.

Q.165 A man whose father was colour blind marries a woman who had a colour blind mother and normal father. What percentage of male children of this couple will be colour blind ?

- (1) 25 % (2) 0 %
- (3) 50 % (4) 75 %

Ans. [3]

Sol.

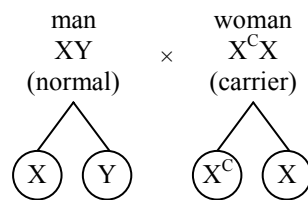

Man is normal, his father is colourblind (x-linked) but x chromosome is not transmitted from his father, woman is carrier b/c her mother is colourblind.

	X	Y
X ^c	X ^c X carrier	X ^c Y colourblind
X	XX Normal	XY Normal

So 50 % male child will be colourblind.

Q.166 In a population of 1000 individuals 360 belong to genotype AA, 480 to Aa and the remaining 160 to aa. Based on this data, the frequency of allele A in the population is -

- (1) 0.4 (2) 0.5
- (3) 0.6 (4) 0.7

Ans. [3]

Sol.

hardy weinbergh law

$$p^2 + 2pq + q^2 = 1$$

(AA) (Aa) (aa)

360 480 160

A → p

a → q

(p + q = 1)

aa = 160

$$aa = \frac{160}{1000} \times 100 = 16\%$$

$$q^2 = 0.16$$

$$q = 0.4 \text{ (p + q = 1)}$$

$$\text{so } p = 0.6$$

Q.167 A human female with Turner's syndrome -

- (1) has 45 chromosomes with XO
- (2) has one additional X chromosome
- (3) exhibits male characters
- (4) is able to produce children with normal husband

Ans. [1]

Sol.

Q.168 Select the correct option -

	Direction of RNA synthesis	Direction of reading of the template DNA strand
(1)	5' — 3'	3' — 5'
(2)	3' — 5'	5' — 3'
(3)	5' — 3'	5' — 3'
(4)	3' — 5'	3' — 5'

Ans. [1]

Sol.



So direction of RNA synthesis in 5' → 3' and direction of reading of template DNA strand.

Q.169 Commonly used vectors for human genome sequencing are -

- (1) T-DNA
- (2) BAC and YAC
- (3) Expression Vectors
- (4) T/A Cloning Vectors

Ans. [2]

Sol.

Q.170 Forelimbs of cat, lizard used in walking; forelimbs of whale used in swimming and forelimbs of bats used in flying are an example of-

- (1) Analogous organs
- (2) Adaptive radiation
- (3) Homologous organs
- (4) Convergent evolution

Ans. [3]

Sol.

They are the organs with common origin but perform different function.

Q.171 Which one of the following are analogous structures ?

- (1) Wings of Bat and Wings of Pigeon
- (2) Gills of Prawn and Lungs of Man
- (3) Thorns of Bougainvillea and Tendrils of Cucurbita
- (4) Flippers of Dolphin and legs of Horse

Ans. [1]

Sol.

Bat wings and bird wings are Analogous as flight structures. Their structure and function have evolved by different routes from a flightless reptilian ancestor.

Q.172 Which is the particular type of drug that is obtained from the plant whose one flowering branch is shown below ?



- (1) Hallucinogen
- (2) Depressant
- (3) Stimulant
- (4) Pain-killer

Ans. [1]

Sol.

This is flowering branch of Datura having halucinogenic properties.

Q.173 At which stage of HIV infection does one usually show symptoms of AIDS ?

- (1) Within 15 days of sexual contact with an infected person

(2) When the infected retro virus enters host cells

(3) When HIV damages large number of helper T-Lymphocytes

(4) When the viral DNA is produced by reverse transcriptase

Ans. [3]

Sol.

When HIV damage T-helper T-lymphocyte, person become immunodeficient so immunodeficient symptoms appear in the phage.

Q.174 To obtain virus-free healthy plants from a diseased one by tissue culture technique, which part/parts of the diseased plant will be taken ?

- (1) Apical meristem only
- (2) Palisade parenchyma
- (3) Both apical and axillary meristems
- (4) Epidermis only

Ans. [3]

Sol. In plant tissue culture virus free plants can be obtained by both apical and axillary meristems as rate of division of meristemetic tissue is faster than the rate of reproduction of virus.

Q.175 What gases are produced in anaerobic sludge digesters ?

- (1) Methane and CO₂ only
- (2) Methane, hydrogen sulphide and CO₂
- (3) Methane, Hydrogen sulphide and O₂
- (4) Hydrogen sulphide and CO₂

Ans. [2]

Sol.

In anaerobic sludge digester, due to activity of anaerobic bacteria like Methanomonas & Sulphur bacteria the gases like CH₄, H₂S & CO₂ are produced.

Q.176 Just as a person moving from Delhi to Shimla to escape the heat for the duration of hot summer, thousands of migratory birds from Siberia and other extremely cold northern regions move to -

- (1) Western Ghat
- (2) Meghalaya
- (3) Corbett National Park
- (4) Keolado National Park

Ans. [4]

Sol.

Migratory birds from Sibarua are Generally migrates at Keolado National park Bharatpur during winter season.

Q.177 Given below is a simplified model of phosphorus cycling in a terrestrial ecosystem with four blanks (A-D). Identify the blanks.

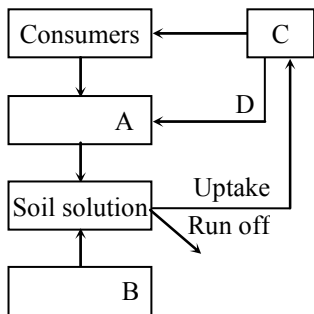

Options :

	A	B	C	D
(1)	Rock minerals	Detritus	Litter fall	Producers
(2)	Litter fall	Producers	Rock minerals	Detritus
(3)	Detritus	Rock minerals	Producers	Litter fall
(4)	Producers	Litter fall	Rock minerals	Detritus

Ans. [3]

Sol.

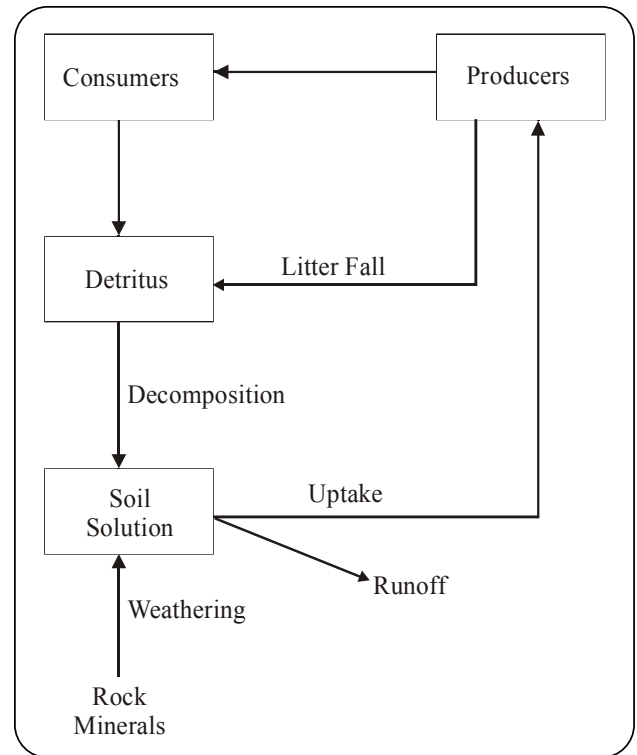

- A – Detritous
- B – Rock minerals
- C – Produces
- D – Litter fall

Q.178 Given below is the representation of the extent of global diversity of invertebrates. What groups the four portions (A-D) represent respectively ?

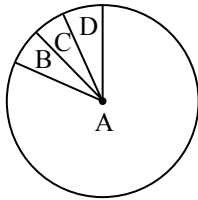

	A	B	C	D
(1)	Insects	Crustaceans	Other animal groups	Molluscs
(2)	Crustaceans	Insects	Molluscs	Other animals groups
(3)	Molluscs	Other animals group	Crustaceans	Insects
(4)	Insects	Molluscs	Crustaceans	Other animal groups

Ans. [4]

Sol.

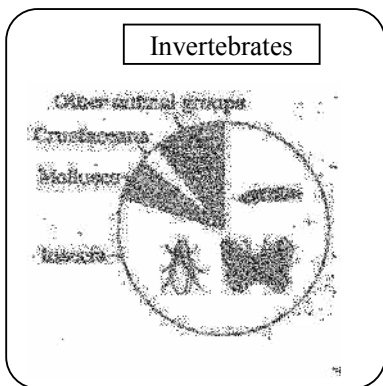

Q.179 A scrubber in the exhaust of a chemical industrial plant removes -

- (1) gases like sulphur dioxide
- (2) particulate matter of the size 5 micrometer or above
- (3) gases like ozone and methane
- (4) particular matter of the size 2.5 micrometer or less

Ans. [1]

Sol.

Scrubber in chemical industries are used to remove SPM gases like sulphur dioxides.

Q.180 If 20 J of energy is trapped at producer level, then how much energy will be available to peacock as food in the following chain ?

plant → mice → snake → peacock

- (1) 0.02 J
- (2) 0.002 J
- (3) 0.2 J
- (4) 0.0002 J

Ans. [1]

Sol. CP Students may find similar question in CP Exercise Sheet: [Chapter : Ecology (Ecosystem), Level # 2, Page No. 124, Q. 52]

This is based on Lindemann's 10 percent Law so if plant trapped 20 Joule energy then

Plant → mice → snake → peacock

20 J 2 J 0.2 J 0.02 J

So energy available for Peacock is 0.02 J.