



collegebatch.com

click to campus

NATA 2017 Question Paper with Solution

National Aptitude Test in Architecture (NATA)

Download more NATA Previous Year Question Papers: [Click Here](#)

PART A — (Mathematics)

1. The value of  $\int_{-\frac{\pi}{4}}^{\frac{\pi}{4}} (x^2 \sin x + x^3) dx$  is
- (A)  $\frac{1}{2} + \frac{\pi^4}{64}$  (B)  $\frac{1}{2} - \frac{\pi^4}{64}$   
 (C) 0 (D)  $\frac{\pi^4}{64}$
2. The value of  $\lambda$  for which the straight line  $(2x + 3y + 4) + \lambda(6x - y + 12) = 0$  is parallel to  $y$ -axis is
- (A) 1 (B) 2  
 (C) 3 (D) 4
3. The sum of the perpendicular distances from the origin to the planes  $12x - 3y + 4z + 26 = 0$  and  $2x - 4y + 4z + 18 = 0$  is
- (A) 5 (B) 44  
 (C) 25 (D) 8
4. Let  $a, b, c$  be distinct real numbers such that  $\Delta = \begin{vmatrix} 2014 & 2015 & 2013 + a^{-1} \\ 2015 & 2016 & 2013 + b^{-1} \\ 2016 & 2017 & 2013 + c^{-1} \end{vmatrix} = 0$ . Then
- (A)  $a, b, c$  are in A.P. (B)  $a, b, c$  are in G.P.  
 (C)  $a^2, b^2, c^2$  are in A.P. (D)  $a, b, c$  are in H.P.
5. Solution of the differential equation  $\frac{dy}{dx} = y^2$  with the condition  $y(1) = 1$  is
- (A)  $2y - xy = 1$  (B)  $2y + xy = 1$   
 (C)  $2y - xy = 0$  (D)  $2y + xy = 0$
6. Derivative of  $\sin x$  with respect to  $\cos x$  is
- (A)  $\tan x$  (B)  $-\tan x$   
 (C)  $\cot x$  (D)  $-\cot x$
7. The points  $(a, 2), (0, b), (1, 1)$  are collinear. Then
- (A)  $ab = a + b + 2$  (B)  $ab = a + b - 2$   
 (C)  $ab = a + b$  (D)  $ab = a - b$

8. Value of the determinant  $\begin{vmatrix} 1 & w & w^2 \\ w & w^2 & 1 \\ w^2 & 1 & w \end{vmatrix}$ , where  $w$  is the cube root of unity is
- (A) 1 (B) 0  
(C)  $w$  (D)  $w^2$
9. The system of linear equations  $-2x + y + z = a$ ,  $x - 2y + z = b$ ,  $x + y - 2z = c$  have infinitely many solutions if
- (A)  $a = 0, b = 0, c = 0$  (B)  $a + b = c$   
(C)  $a + b + c = 0$  (D)  $a + b - c = 0$
10. The monthly rate of sales for the first 11 months of the year of a certain salesman was ₹ 12,000. But due to his illness during the last month, the average sales for the whole year came down to ₹ 11,375. The value of the sale during the last month was
- (A) ₹ 4,500 (B) ₹ 6,000  
(C) ₹ 10,000 (D) ₹ 8,000
11. The probability that a man will live for 10 more years is  $\frac{1}{4}$  and the probability that his wife will live for 10 more years is  $\frac{1}{3}$ . The probability that neither the husband nor the wife will be alive after 10 years is
- (A)  $\frac{5}{12}$  (B)  $\frac{1}{2}$   
(C)  $\frac{7}{12}$  (D)  $\frac{11}{12}$
12. The area bounded by the curve  $y = x^3, y = 0, x = 1$  is
- (A) 1 (B)  $\frac{1}{2}$   
(C)  $\frac{1}{3}$  (D)  $\frac{1}{4}$
13. The degree and order of the differential equation  $\left(\frac{d^3y}{dx^3}\right)^2 + \left(\frac{dy}{dx}\right)^4 + y^3 = 0$  is
- (A) 3 and 2 respectively (B) 4 and 3 respectively  
(C) 2 and 3 respectively (D) 2 and 4 respectively
14. If  ${}^nC_7 = {}^nC_4$ , then the value of  $n$  is
- (A) 14 (B) 12  
(C) 11 (D) 10

15. If  $a, b, c$  are non-zero, then number of solutions of  $\frac{2x^2}{a^2} - \frac{y^2}{b^2} - \frac{z^2}{c^2} = 0$ ,  $-\frac{x^2}{a^2} - \frac{y^2}{b^2} + \frac{2z^2}{c^2} = 0$ ,  $-\frac{x^2}{a^2} + \frac{2y^2}{b^2} - \frac{z^2}{c^2} = 0$  is
- (A) 6 (B) 8  
(C) 9 (D) infinite
16. If  $A = \begin{bmatrix} \frac{1}{\sqrt{2}} & \frac{1}{\sqrt{2}} & 0 \\ -\frac{1}{\sqrt{2}} & \frac{1}{\sqrt{2}} & 0 \\ 0 & 0 & 1 \end{bmatrix}$ , then  $A^{-1}$  is
- (A)  $A$  (B)  $A^T$   
(C)  $A^2$  (D)  $A^3$
17.  $m$  men and  $w$  women are to be seated in a row so that all women sit together. The number of ways in which they can be seated is
- (A)  ${}^{m+w}C_w$  (B)  $m!w!$   
(C)  $m!(w-1)!$  (D)  $(m+1)!w!$
18. The number of solutions of the pair of equations  $2\sin^2\theta - \cos 2\theta = 0$  and  $2\cos^2\theta - 3\sin\theta = 0$  in the interval  $[0, 2\pi]$  is
- (A) zero (B) two  
(C) one (D) four
19. A point moves so that the sum of the squares of its distances from the six faces of a cube given by  $x = \pm 1, y = \pm 1, z = \pm 1$  is 10 units. The locus of the point is
- (A)  $x^2 + y^2 + z^2 = 2$  (B)  $x^2 + y^2 + z^2 = 1$   
(C)  $x + y + z = 2$  (D)  $x + y + z = 1$
20. If the function  $f(x) = \begin{cases} x^2 - (A+2)x + A & \text{for } x \neq 2 \\ 2 & \text{for } x = 2 \end{cases}$  is continuous at  $x = 2$ , then
- (A)  $A = 0$  (B)  $A = 1$   
(C)  $A = 2$  (D)  $A = 3$

PART A — (General Aptitude)

21. A directional post is erected on a crossing. Due to heavy storm it turned in such a way that the arrow which was first showing South is now showing East. A car went in a direction thinking it is West. In what direction is the car actually moving?
- (A) North (B) West  
(C) East (D) South
22. Let  $E$  and  $F$  be any two sets. Which of the following statements is NOT correct?
- (A)  $E - F = E - (E \cap F)$   
(B)  $(E \cup F) - F = E - (E \cap F)$   
(C)  $E - (E \cap F) = E \cap F^c$   
(D)  $(E \cup F) - F = (E - F) \cup (E \cap F)$
23. A set  $P$  has 20 elements. The number of subsets of  $P$  containing odd number of elements is
- (A)  $2^{18} + 20$  (B)  $2^{19}$   
(C)  $2^{19} - 1$  (D)  $2^{20} - 128$
24. Let  $P = \{1, 3, 5, 7, 9\}$  and  $R = \{(1, 3), (3, 5), (1, 5), (9, 7), (7, 5), (9, 5)\}$ . Then  $R$
- (A) is not reflexive but symmetric and transitive  
(B) is neither reflexive nor symmetric but transitive  
(C) is neither transitive nor symmetric but reflexive  
(D) is an equivalence relation
25. Let  $P = \{1, 2, 3\}$ ,  $Q = \{2, 3, 4\}$ . Then the number of elements in  $P \times Q$  is
- (A) 9 (B) 7  
(C) 6 (D) 4

26. In a project, the share of material and labour costing is 3:2. In the labour component, the electrician gets 5%. What is the total project cost if an electrician gets ₹ 25,000/-?
- (A) ₹ 12.5 Lakh (B) ₹ 25 Lakh  
(C) ₹ 125 Lakh (D) ₹ 62.5 Lakh
27. From a point O, two persons A and B started their journey on XY plane. A went 7 km along north and stopped. B went 5 km west and then 5 km south and stopped. What is the shortest distance between A and B?
- (A) 13 km (B) 7 km  
(C) 12 km (D) 3 km
28. Three cubes of side 2 cm are glued surface to surface horizontally such that it produces a cuboid. What is the surface area of the cuboid?
- (A)  $72 \text{ cm}^2$  (B)  $68 \text{ cm}^2$   
(C)  $64 \text{ cm}^2$  (D)  $56 \text{ cm}^2$

29.

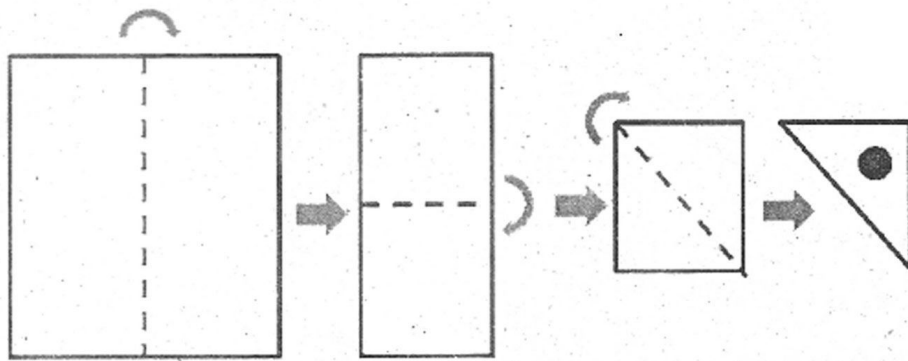

A square paper is folded as shown in the figure (above). A circular hole is created in the triangular portion. Now the paper is unfolded. What will be the right diagram?

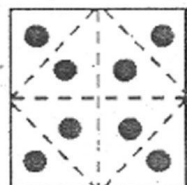

(A)

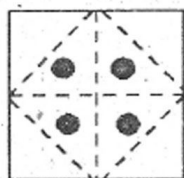

(B)

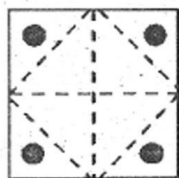

(C)

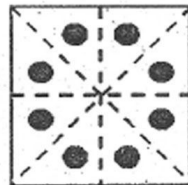

(D)

30. How many total number of triangles are there in the figure given below?

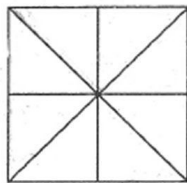

(A) 16

(B) 17

(C) 18

(D) 20

31. The left most figure below shows the top view of an object. Identify the correct elevation from amongst the answer figures, looking in the direction of arrow.

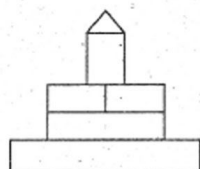

(A)

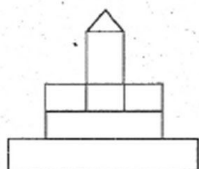

(B)

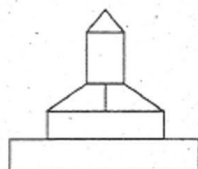

(C)

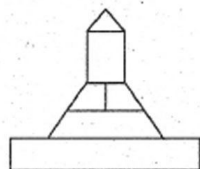

(D)

32. Which one of the following consumes least amount of electricity?

(A) Tungsten bulb

(B) Fluorescent tube

(C) Light Emitting Diodes (LED)

(D) Compact Fluorescent lamp (CFL)

33. Green Architecture is promoted these days because

(A) it costs less initially

(B) it is environment friendly

(C) it lasts longer

(D) it uses good colours

34. World Environment Day is observed on :

(A) February 14

(B) May 01

(C) June 05

(D) August 06

35. Find the odd one from the figures below. Ignore the direction of arrow head.

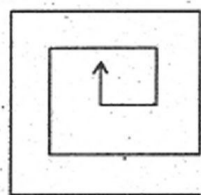

(A)

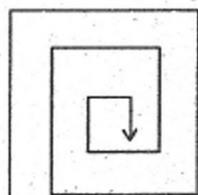

(B)

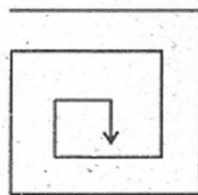

(C)

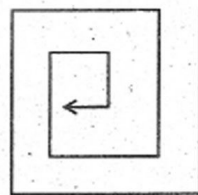

(D)

36. Gypsum is a

(A) mechanically formed sedimentary rock

(B) igneous rock

(C) chemically precipitated sedimentary rock

(D) metamorphic rock

37. Which of the following is a scalar quantity?

(A) energy

(B) momentum

(C) torque

(D) impulse

38. A heavy ladder resting in the floor and against a vertical wall may not be in equilibrium if

(A) floor is smooth and wall is rough

(B) floor is rough and wall is smooth

(C) both floor and wall are rough

(D) both floor and wall are smooth

39. The type of roof suitable in plains where rainfall is meagre and temperature is high is

(A) pitched and slope

(B) flat

(C) vault

(D) shell

40. The angle which an inclined plane makes with the horizontal when a body placed on it is about to slide down is known as angle of

(A) limiting friction

(B) inclination

(C) repose

(D) overturning



41. Nurse Merry has worked more night shifts in a row than Nurse Sujata, who has worked five. Nurse Ruma has worked fifteen night shifts in a row, more than Nurses Merry and Sujata combined. Nurse Priti has worked eight night shifts in a row, less than Nurse Merry. How many night shifts in a row has Nurse Merry worked?
- (A) 10 (B) 9  
(C) 8 (D) 7
42. Unscramble and find the odd one among the following
- (A) NEMJIAS (B) ORES  
(C) MAGNO (D) SOULT
43. X is 1 km northeast of Y. Y is 1 km southeast of Z. W is 1 km west of Z. P is 1 km south of W. Q is 1 km east of P. What is the distance between X and Q in km?
- (A)  $\sqrt{5}$  (B)  $\sqrt{3}$   
(C)  $\sqrt{2}$  (D) 3
44. In a group of four children, Som is younger to Riaz. Shiv is elder to Ansu. Ansu is youngest in the group. Which of the following statements is/are required to find the eldest child in the group?
- Statements : 1. Shiv is younger to Riaz.  
2. Shiv is elder to Som.
- (A) Statements 1 and 2 are both required to determine the eldest child  
(B) Statement 2 by itself determines the eldest child  
(C) Statements 1 and 2 are not sufficient to determine the eldest child  
(D) Statement 1 by itself determines the eldest child
45. Given below are two statements followed by two conclusions. Assuming these statements to be true, decide which one logically follows.
- Statements :
- I. All film stars are playback singers.  
II. All film directors are film stars.
- Conclusions :
- I. All film directors are playback singers.  
II. Some film stars are film directors.
- (A) Only conclusion I follows (B) Only conclusion II follows  
(C) Both conclusions I and II follow (D) Neither conclusion I nor II follows

46. A truncated (horizontally cut in mid-way) hexagonal pyramid has following numbers of surfaces, edges and vertices respectively.
- (A) 8, 16, 12 (B) 6, 12, 10  
(C) 6, 16, 10 (D) 8, 18, 12
47. A circle is inscribed within an equilateral triangle of area  $\sqrt{3}$  sqm. The circumference of the circle is
- (A)  $\frac{\pi}{\sqrt{3}}$  m (B)  $\pi\sqrt{3}$  m  
(C)  $\frac{2\pi}{\sqrt{3}}$  m (D)  $2\pi\sqrt{3}$  m
48. The linear scale of a map is 1 cm = 2 m. The drawing dimensions of an on-site rectangular plot measuring 25 m  $\times$  40 m will be
- (A) 50 cm  $\times$  80 cm (B) 25 cm  $\times$  40 cm  
(C) 12.5 cm  $\times$  20 cm (D) 5 cm  $\times$  8 cm
49. When a clock is seen through a mirror, the hour arm and minute arm are seen at 9 and 4 respectively, so that the time seen is 9 : 20. What will be the actual time after 15 minutes?
- (A) 2:35 (B) 3:35  
(C) 3:55 (D) 2:55
50. Length of a solid diagonal of a cube is 6 cm. The volume of the cube is
- (A)  $24\sqrt{3}$  cm<sup>3</sup> (B) 8 cm<sup>3</sup>  
(C)  $12\sqrt{3}$  cm<sup>3</sup> (D) 27 cm<sup>3</sup>

51. How many surfaces are there in the model? Consider all seen and unseen surfaces.

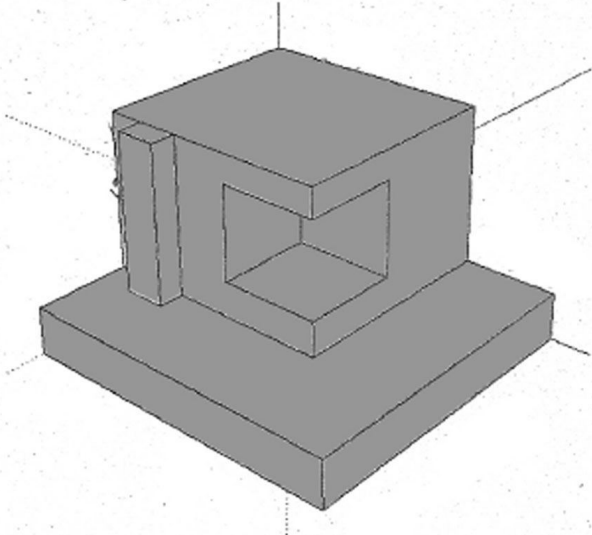

- (A) 21  
(B) 17  
(C) 12  
(D) 15
52. A horizontal supporting crosspiece over an opening is called  
(A) Lattice  
(B) Leader  
(C) Lancet  
(D) Lintel
53. A square is drawn on 1<sup>st</sup> quadrant of  $XY$  plane having consecutive coordinates (counter-clockwise, starting from left bottom) as  $P(2,3)$ ,  $Q(7,3)$ ,  $R(7,8)$ ,  $S(2,8)$  respectively. Thereafter, each side of the square is doubled considering  $P$  as a fixed point and the new square becomes  $PQR'S'$ . Now this new square is mirrored with respect to  $X$  axis. What will be the coordinates for the image of  $R'$  ?  
(A)  $(7, -8)$   
(B)  $(12, -13)$   
(C)  $(-12, -13)$   
(D)  $(-7, 8)$
54. What secondary colour is obtained by mixing Blue and Red colours?  
(A) Pink  
(B) Brown  
(C) Orange  
(D) Purple
55. What is Texture?  
(A) Solid colour  
(B) Type of shape  
(C) Lines drawn in colour  
(D) The way a surface looks and feels

56. Building acoustics concerns

- (A) Water related issues                      (B) Sound related issues  
(C) Ventilation related issues              (D) Daylight related issues

57. Choose the appropriate shadow pattern of this cube (below) at 3:00 p.m. in India.

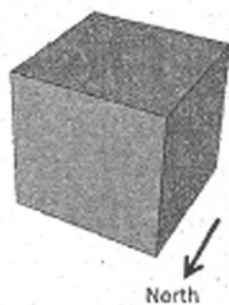

(A)



(B)

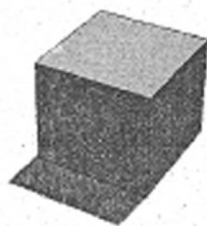

(C)

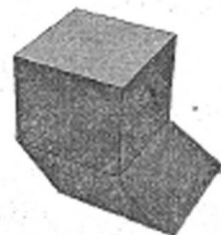

(D)

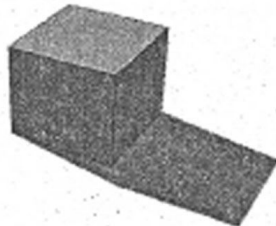

58. Fly ash is a waste product from which of the following:

- (A) Nuclear installation                      (B) Coal mine  
(C) Thermal power plant                      (D) Iron ore conversion

59. French influence in architecture is found at

- (A) Kerala    (B) Sikkim  
(C) Goa    (D) Puducherry

60. How many bricks of dimension  $20\text{ cm} \times 10\text{ cm} \times 10\text{ cm}$  are required to build a wall 12 m long, 3 m high and 30 cm wide, if 10% of the wall is comprised of mortar?

- (A) 4860    (B) 5200  
(C) 4600    (D) 5000

## PART B — (Drawing Test)

1. One late afternoon, you along with your family members were enjoying a boat ride along a river and viewed a spectacular sunset. You noticed that the boat was moving from south to north and all of you were facing north. Suddenly, your youngest brother shouted and told everybody to see the river bank on your right side. You saw a series of high-rise apartment buildings interspersed with trees. But, in the middle, there was a beautiful river ghat, a garden and a small white mosque adjacent to it. Lots of birds were flying around and sitting on its golden dome. In the concrete jungle, the small structure seemed to be a nice relief. Develop a coloured sketch (use dry colour) of what you experienced.
2. You are waiting in a railway platform for catching a local train. Some people are also waiting there with small and big luggage. Few people are sitting on wooden benches. There is a small food shop. You saw that the roof above is sloped. Standing at the entry point of the platform you noticed that the train is coming and has reached almost midway of the length of the platform. Draw a pencil sketch of what you experienced.