



collegebatch.com

click to campus

GATE 2024 Petroleum Engineering (PE) Question Paper

Graduate Aptitude Test in Engineering (GATE)

Download more GATE Previous Year Question Papers: [Click Here](#)

General Aptitude (GA)

Q.1 – Q.5 Carry ONE mark Each

Q.1 If '→' denotes increasing order of intensity, then the meaning of the words [smile → giggle → laugh] is analogous to [disapprove → _____ → chide]. Which one of the given options is appropriate to fill the blank?

- (A) reprove
- (B) praise
- (C) reprise
- (D) grieve

Q.2 Find the odd one out in the set: {19, 37, 21, 17, 23, 29, 31, 11}

- (A) 21
- (B) 29
- (C) 37
- (D) 23

Q.3 In the following series, identify the number that needs to be changed to form the Fibonacci series.

1, 1, 2, 3, 6, 8, 13, 21,...

- (A) 8
- (B) 21
- (C) 6
- (D) 13

Q.4 The real variables x, y, z , and the real constants p, q, r satisfy

$$\frac{x}{pq - r^2} = \frac{y}{qr - p^2} = \frac{z}{rp - q^2}$$

Given that the denominators are non-zero, the value of $px + qy + rz$ is

- (A) 0
- (B) 1
- (C) pqr
- (D) $p^2 + q^2 + r^2$

Q.5 Take two long dice (rectangular parallelepiped), each having four rectangular faces labelled as 2, 3, 5, and 7. If thrown, the long dice cannot land on the square faces and has $1/4$ probability of landing on any of the four rectangular faces. The label on the top face of the dice is the score of the throw.

If thrown together, what is the probability of getting the sum of the two long dice scores greater than 11?

- (A) $3/8$
- (B) $1/8$
- (C) $1/16$
- (D) $3/16$

GATE 2024

Q.6 – Q.10 Carry TWO marks Each

Q.6 In the given text, the blanks are numbered (i)–(iv). Select the best match for all the blanks.

Prof. P _____ (i) _____ merely a man who narrated funny stories. _____ (ii) _____ in his blackest moments he was capable of self-deprecating humor.

Prof. Q _____ (iii) _____ a man who hardly narrated funny stories. _____ (iv) _____ in his blackest moments was he able to find humor.

(A) (i) was (ii) Only (iii) wasn't (iv) Even

(B) (i) wasn't (ii) Even (iii) was (iv) Only

(C) (i) was (ii) Even (iii) wasn't (iv) Only

(D) (i) wasn't (ii) Only (iii) was (iv) Even

Q.7 How many combinations of non-null sets A, B, C are possible from the subsets of $\{2, 3, 5\}$ satisfying the conditions: (i) A is a subset of B, and (ii) B is a subset of C?

(A) 28

(B) 27

(C) 18

(D) 19

- Q.8 The bar chart gives the batting averages of VK and RS for 11 calendar years from 2012 to 2022. Considering that 2015 and 2019 are world cup years, which one of the following options is true?

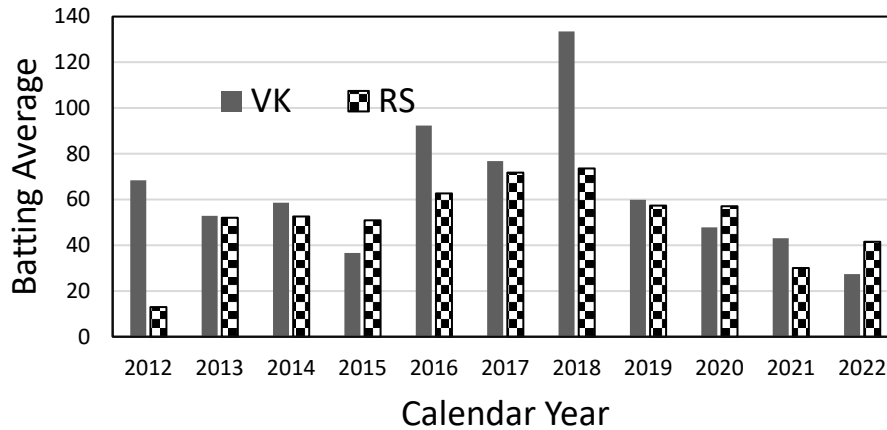

- (A) RS has a higher yearly batting average than that of VK in every world cup year.
- (B) VK has a higher yearly batting average than that of RS in every world cup year.
- (C) VK's yearly batting average is consistently higher than that of RS between the two world cup years.
- (D) RS's yearly batting average is consistently higher than that of VK in the last three years.

Q.9 A planar rectangular paper has two V-shaped pieces attached as shown below.

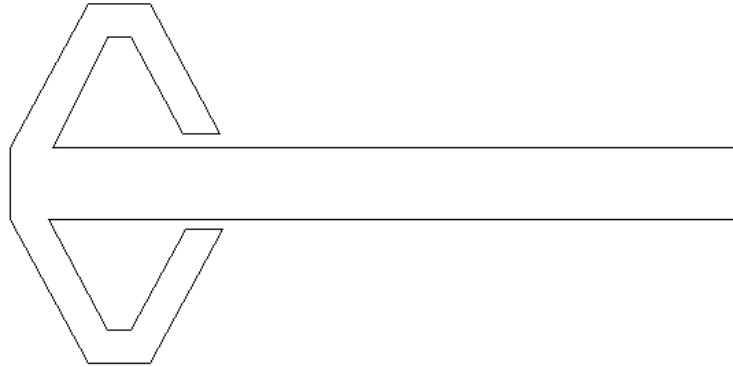

This piece of paper is folded to make the following closed three-dimensional object.

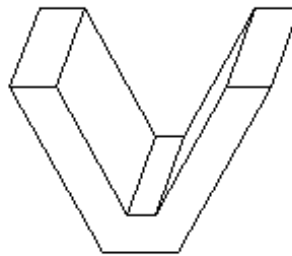

The number of folds required to form the above object is

- (A) 9
- (B) 7
- (C) 11
- (D) 8

Q.10 Four equilateral triangles are used to form a regular closed three-dimensional object by joining along the edges. The angle between any two faces is

(A) 30°

(B) 60°

(C) 45°

(D) 90°

GATE 2024

Q.11 – Q.35 Carry ONE mark Each

Q.11 If $F_1(Q, q) = Qq$ is the generating function of a canonical transformation from (p, q) to (P, Q) , then which one of the following relations is correct?

(A) $\frac{p}{P} = \frac{Q}{q}$

(B) $\frac{P}{p} = \frac{Q}{q}$

(C) $\frac{p}{P} = -\frac{Q}{q}$

(D) $\frac{P}{p} = -\frac{Q}{q}$

Q.12 An unpolarized plane electromagnetic wave in a dielectric medium 1 is incident on a plane interface that separates medium 1 from another dielectric medium 2. Medium 1 and medium 2 have refractive indices n_1 and n_2 , respectively, with $n_2 > n_1$. If the angle of incidence is $\tan^{-1}\left(\frac{n_2}{n_1}\right)$, which one of the following statements is true?

(A) The reflected wave is unpolarized

(B) The reflected wave is polarized parallel to the plane of incidence

(C) The reflected wave is polarized perpendicular to the plane of incidence

(D) There is no transmitted wave

Q.13 The wavefunction of a particle in an infinite one-dimensional potential well at time t is

$$\Psi(x, t) = \sqrt{\frac{2}{3}} e^{-iE_1 t/\hbar} \psi_1(x) + \frac{1}{\sqrt{6}} e^{i\pi/6} e^{-iE_2 t/\hbar} \psi_2(x) + \frac{1}{\sqrt{6}} e^{i\pi/4} e^{-iE_3 t/\hbar} \psi_3(x)$$

where ψ_1, ψ_2 and ψ_3 are the normalized ground state, the normalized first excited state and the normalized second excited state, respectively. E_1, E_2 and E_3 are the eigen-energies corresponding to ψ_1, ψ_2 and ψ_3 , respectively. The expectation value of energy of the particle in state $\Psi(x, t)$ is

- (A) $\frac{17}{6} E_1$
- (B) $\frac{2}{3} E_1$
- (C) $\frac{3}{2} E_1$
- (D) $14 E_1$

Q.14 If a thermodynamical system is adiabatically isolated and experiences a change in volume under an externally applied constant pressure, then the thermodynamical potential minimized at equilibrium is the

- (A) enthalpy
- (B) Helmholtz free energy
- (C) Gibbs free energy
- (D) grand potential

Q.15 The mean distance between the two atoms of HD molecule is r , where H and D denote hydrogen and deuterium, respectively. The mass of the hydrogen atom is m_H . The energy difference between two lowest lying rotational states of HD in multiples of $\hbar^2/(m_H r^2)$ is

- (A) $\frac{3}{2}$
- (B) $\frac{2}{3}$
- (C) 6
- (D) $\frac{4}{3}$

Q.16 Crystal structures of two metals A and B are two-dimensional square lattices with same lattice constant a . Electrons in metals behave as free electrons. The Fermi surfaces corresponding to A and B are shown by solid circles in figures.

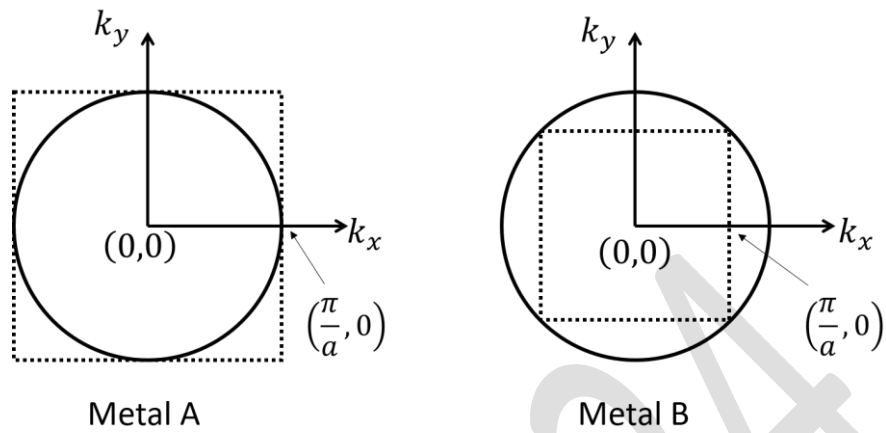

The electron concentrations in A and B are n_A and n_B , respectively. The value of $\left(\frac{n_B}{n_A}\right)$ is

- (A) 3
- (B) 2
- (C) $3\sqrt{3}$
- (D) $\sqrt{2}$

Q.17 Consider the induced nuclear fission reaction

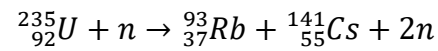

where neutron momenta in both initial and final states are negligible. The ratio of the kinetic energies (KE) of the daughter nuclei,

$$\frac{\text{KE}({}_{37}^{93}\text{Rb})}{\text{KE}({}_{55}^{141}\text{Cs})}$$

is _____

- (A) $\frac{93}{141}$
- (B) $\frac{141}{93}$
- (C) 1
- (D) 0

Q.18 The symbols C, D, V_{in} and V_o shown in the figure denote capacitor, ideal diode, input voltage and output voltage, respectively.

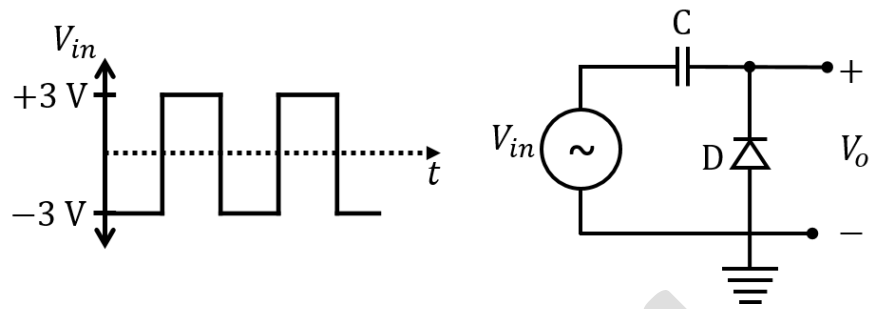

Which one of the following output waveforms (V_o) is correct for the given input waveform (V_{in})?

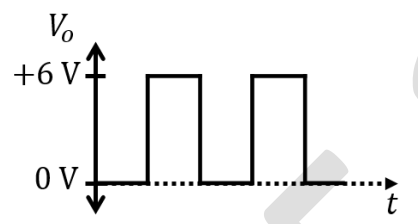
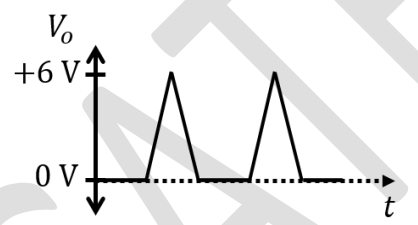
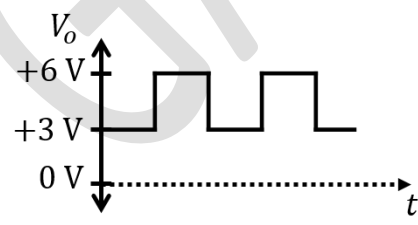
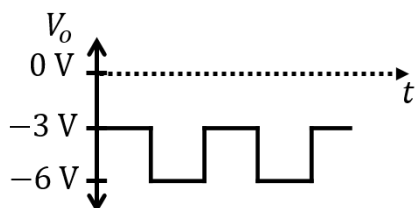
- (A) 
- (B) 
- (C) 
- (D) 

Q.19 Let N_e and T_e , respectively, denote number and kinetic energy of electrons produced in a nuclear beta decay. Which one of the following distributions is correct?

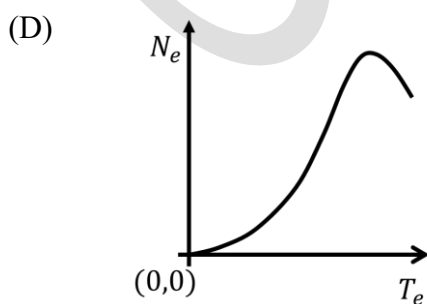
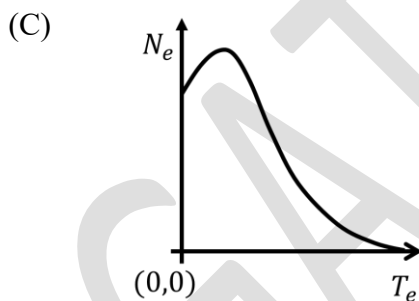
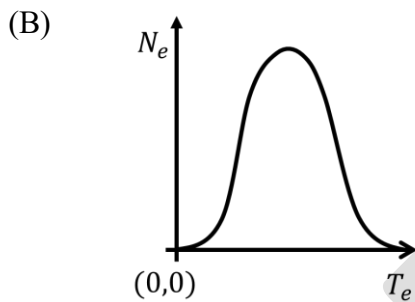
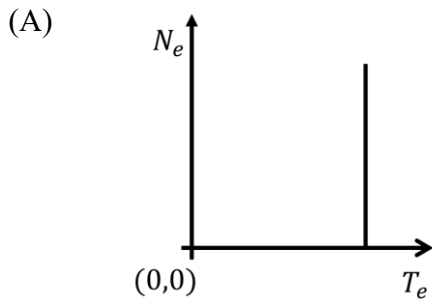

Q.20 An infinitely long cylinder of radius R carries a frozen-in magnetization $\vec{M} = ke^{-s}\hat{z}$, where k is a constant and s is the distance from the axis of cylinder. The magnetic permeability of free space is μ_0 . There is no free current present anywhere. The magnetic flux density (\vec{B}) inside the cylinder is

- (A) 0
- (B) $\mu_0 ke^{-R}\hat{z}$
- (C) $\mu_0 ke^{-s}\hat{z}$
- (D) $\mu_0 ke^{-s}\left(\frac{R}{s}\right)\hat{z}$

Q.21 Atomic numbers of V, Cr, Fe and Zn are 23, 24, 26 and 30, respectively. Which one of the following materials does NOT show an electron spin resonance (ESR) spectra?

- (A) V
- (B) Cr
- (C) Fe
- (D) Zn

Q.22 A particle is subjected to a potential

$$V(x) = \begin{cases} \infty, & x \leq 0 \\ V_0, & a \leq x \leq b \\ 0, & \text{elsewhere} \end{cases}$$

Here, $a > 0$ and $b > a$. If the energy of the particle $E < V_0$, which one of the following schematics is a valid quantum mechanical wavefunction (Ψ) for the system?

(A)

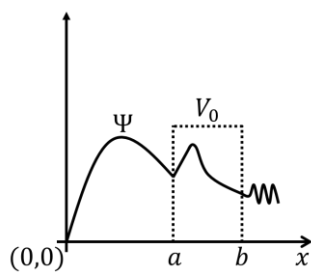

(B)

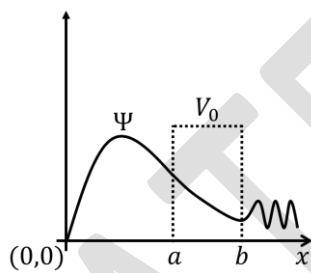

(C)

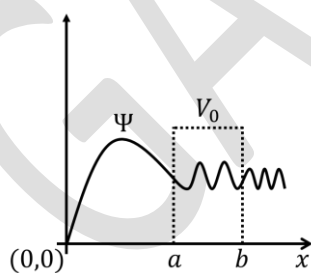

(D)

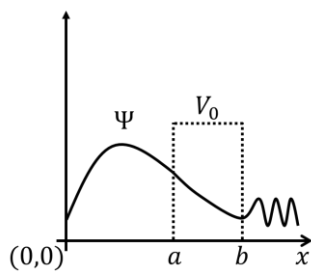

Q.23 Let $\rho(\vec{p}, \vec{q}, t)$ be the phase space density of an ensemble of a system. The Hamiltonian of the system is $H(\vec{p}, \vec{q})$. If $\{A, B\}$ denotes the Poisson bracket of A and B , then

$$\frac{d\rho}{dt} = 0$$

implies

(A) $\frac{\partial \rho}{\partial t} = 0$

(B) $\frac{\partial \rho}{\partial t} \propto \{\rho, H\}$

(C) $\frac{\partial \rho}{\partial t} \propto \left\{ \rho, \frac{\vec{p} \cdot \vec{q}}{2} \right\}$

(D) $\frac{\partial \rho}{\partial t} \propto \left\{ \rho, \frac{\vec{q} \cdot \vec{q}}{2} \right\}$

Q.24 Consider the following circuit:

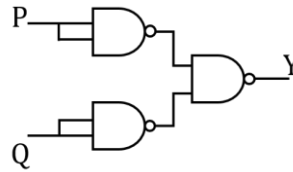

Suppose the input signal P is



and the input signal Q is



Which one of the following output signals is correct?

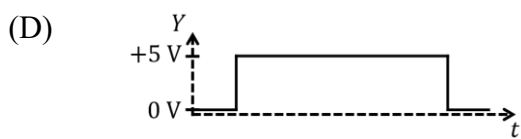
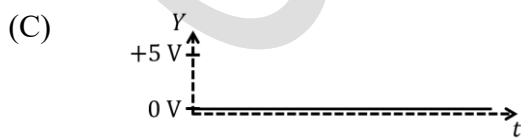
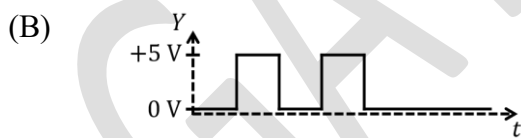

Q.25 An inertial observer sees two spacecrafts S and T flying away from each other along x -axis with individual speed $0.5c$, where c is the speed of light. The speed of T with respect to S is

(A) $\frac{4}{5}c$

(B) $\frac{4}{3}c$

(C) c

(D) $\frac{2}{3}c$

Q.26 Let P , Q and R be three different nuclei. Which one of the following nuclear processes is possible?

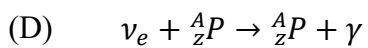
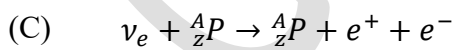
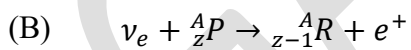
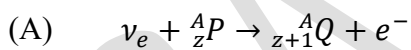

Q.27 The temperature dependence of the electrical conductivity (σ) of three intrinsic semiconductors A, B and C is shown in figure.

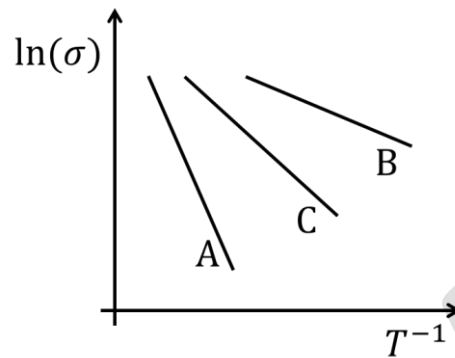

Let E_A , E_B and E_C be the bandgaps of A, B and C, respectively. Which one of the following relations is correct?

- (A) $E_C > E_A > E_B$
- (B) $E_B > E_C > E_A$
- (C) $E_A > E_B > E_C$
- (D) $E_A > E_C > E_B$

Q.28 Following trial wavefunctions

$$\phi_1 = e^{-Z'(r_1+r_2)}$$

and

$$\phi_2 = e^{-Z'(r_1+r_2)}(1 + g|\vec{r}_1 - \vec{r}_2|)$$

are used to get a variational estimate of the ground state energy of the helium atom. Z' and g are the variational parameters, \vec{r}_1 and \vec{r}_2 are the position vectors of the electrons. Let E_0 be the exact ground state energy of the helium atom. E_1 and E_2 are the variational estimates of the ground state energy of the helium atom corresponding to ϕ_1 and ϕ_2 , respectively. Which one of the following options is true?

- (A) $E_1 \leq E_0, E_2 \leq E_0, E_1 \geq E_2$
- (B) $E_1 \geq E_0, E_2 \leq E_0, E_1 \geq E_2$
- (C) $E_1 \leq E_0, E_2 \geq E_0, E_1 \leq E_2$
- (D) $E_1 \geq E_0, E_2 \geq E_0, E_1 \geq E_2$

Q.29 The wavefunction for a particle is given by the form $e^{-(i\alpha x + \beta)}$, where α and β are real constants. In which one of the following potentials $V(x)$, the particle is moving?

- (A) $V(x) \propto \alpha^2 x^2$
- (B) $V(x) \propto e^{-\alpha x}$
- (C) $V(x) = 0$
- (D) $V(x) \propto \sin(\alpha x)$

Q.30 Consider a volume integral

$$I = \int_V \nabla^2 \left(\frac{1}{r} \right) dV$$

over a volume V , where $r = \sqrt{x^2 + y^2 + z^2}$. Which of the following statement is/are correct?

- (A) $I = -4\pi$, if $r = 0$ is inside the volume V
- (B) Integrand vanishes for $r \neq 0$
- (C) $I = 0$, if $r = 0$ is not inside the volume V
- (D) Integrand diverges as $r \rightarrow \infty$

Q.31 The complex function

$$e^{-\left(\frac{2}{z-1}\right)}$$

has _____

- (A) a simple pole at $z = 1$
- (B) an essential singularity at $z = 1$
- (C) a residue equal to -2 at $z = 1$
- (D) a branch point at $z = 1$

Q.32 The minimum number of basic logic gates required to realize the Boolean expression $B \cdot (A + B) + A \cdot (\bar{B} + A)$ is _____ (in integer).

Q.33 The vapor pressure (P) of solid ammonia is given by $\ln(P) = 23.03 - \frac{3754}{T}$, while that of liquid ammonia is given by $\ln(P) = 19.49 - \frac{3063}{T}$, where T is the temperature in K.

The temperature of the triple point of ammonia is _____ K (rounded off to two decimal places).

Q.34 The electric field in a region depends only on x and y coordinates as

$$\vec{E} = k \frac{(x \hat{x} + y \hat{y})}{x^2 + y^2}$$

where k is a constant. The flux of \vec{E} through the surface of a sphere of radius R with its center at the origin is $\pi k R$, where the value of n is _____ (in integer).

Q.35 The Hamiltonian of a system of N particles in volume V at temperature T is

$$H = \sum_{i=1}^{2N} a_i q_i^2 + \sum_{i=1}^{2N} b_i p_i^2$$

where a_i and b_i are positive constants. The ensemble average of the Hamiltonian is $\alpha N k_B T$, where k_B is the Boltzmann constant. The value of α is _____ (in integer).

Q.36 – Q.65 Carry TWO marks Each

Q.36 Binding energy and rest mass energy of a two-nucleon bound state are denoted by B and mc^2 , respectively, where c is the speed of light. The minimum energy of a photon required to dissociate the bound state is

(A) B

(B) $B \left(1 + \frac{B}{2mc^2} \right)$

(C) $B \left(1 - \frac{B}{2mc^2} \right)$

(D) $B - mc^2$

Q.37 The spin-orbit interaction in a hydrogen-like atom is given by the Hamiltonian

$$H' = -k\vec{L} \cdot \vec{S}$$

where k is a real constant. The splitting between levels ${}^2p_{3/2}$ and ${}^2p_{1/2}$ due to this interaction is

(A) $\frac{1}{2}k\hbar^2$

(B) $\frac{3}{2}k\hbar^2$

(C) $\frac{3}{4}k\hbar^2$

(D) $2k\hbar^2$

Q.38 Consider the Lagrangian $L = m\dot{x}\dot{y} - m\omega_0^2 xy$. If p_x and p_y denote the generalized momenta conjugate to x and y , respectively, then the canonical equations of motion are

(A) $\dot{x} = \frac{p_x}{m}$, $\dot{p}_x = -m\omega_0^2 x$, $\dot{y} = \frac{p_y}{m}$, $\dot{p}_y = -m\omega_0^2 y$

(B) $\dot{x} = \frac{p_x}{m}$, $\dot{p}_x = m\omega_0^2 x$, $\dot{y} = \frac{p_y}{m}$, $\dot{p}_y = m\omega_0^2 y$

(C) $\dot{x} = \frac{p_y}{m}$, $\dot{p}_x = -m\omega_0^2 y$, $\dot{y} = \frac{p_x}{m}$, $\dot{p}_y = -m\omega_0^2 x$

(D) $\dot{x} = \frac{p_y}{m}$, $\dot{p}_x = m\omega_0^2 y$, $\dot{y} = \frac{p_x}{m}$, $\dot{p}_y = m\omega_0^2 x$

Q.39 The X-ray diffraction pattern of a monatomic cubic crystal with rigid spherical atoms of radius 1.56 \AA shows several Bragg reflections of which the reflection appearing at the lowest 2θ value is from (111) plane. If the wavelength of X-ray used is 0.78 \AA , the Bragg angle (in 2θ , rounded off to one decimal place) corresponding to this reflection and the crystal structure, respectively, are

(A) 21.6° and body centered cubic

(B) 17.6° and face centered cubic

(C) 10.8° and body centered cubic

(D) 8.8° and face centered cubic

Q.40 In a parallel plate capacitor, the plate at $x = 0$ is grounded and the plate at $x = d$ is maintained at a potential V_0 . The space between the two plates is filled with a linear dielectric of permittivity $\epsilon = \epsilon_0 \left(1 + \frac{x}{d}\right)$, where ϵ_0 is the permittivity of free space. Neglecting the edge effects, the electric field (\vec{E}) inside the capacitor is

(A) $-\frac{V_0}{(d+x)\ln 2} \hat{x}$

(B) $-\frac{V_0}{d} \hat{x}$

(C) $-\frac{V_0}{(d+x)} \hat{x}$

(D) $-\frac{V_0 d}{(d+x)x} \hat{x}$

Q.41 The equation of motion for the forced simple harmonic oscillator is

$$\ddot{x}(t) + \omega^2 x(t) = F \cos(\omega t)$$

where $x(t=0) = 0$ and $\dot{x}(t=0) = 0$. Which one of the following options is correct?

(A) $x(t) \propto t \sin(\omega t)$

(B) $x(t) \propto t \cos(\omega t)$

(C) $x(t) = \infty$

(D) $x(t) \propto e^{\omega t}$

Q.42 An atom is subjected to a weak uniform magnetic field \vec{B} . The number of lines in its Zeeman spectrum for transition from $n = 2, l = 1$ to $n = 1, l = 0$ is

- (A) 8
- (B) 10
- (C) 12
- (D) 5

Q.43 Consider two matrices: $P = \begin{bmatrix} 1 & 2 \\ 0 & 1 \end{bmatrix}$ and $Q = \begin{bmatrix} 1 & 0 \\ 0 & 1 \end{bmatrix}$.

Which of the following statement is/are true?

- (A) P and Q have same set of eigenvalues
- (B) P and Q commute with each other
- (C) P and Q have different sets of linearly independent eigenvectors
- (D) P is diagonalizable

Q.44 An infinite one dimensional lattice extends along x -axis. At each lattice site there exists an ion with spin $\frac{1}{2}$. The spin can point either in $+z$ or $-z$ direction only. Let S_P , S_F , and S_A denote the entropies of paramagnetic, ferromagnetic and antiferromagnetic configurations, respectively. Which of the following relation is/are true?

- (A) $S_P > S_F$
- (B) $S_A > S_F$
- (C) $S_A = 4 S_F$
- (D) $S_P > S_A$

GATE 2024

Q.45 Consider a vector field $\vec{F} = (2xz + 3y^2)\hat{y} + 4yz^2\hat{z}$. The closed path ($\Gamma: A \rightarrow B \rightarrow C \rightarrow D \rightarrow A$) in $z = 0$ plane is shown in figure.

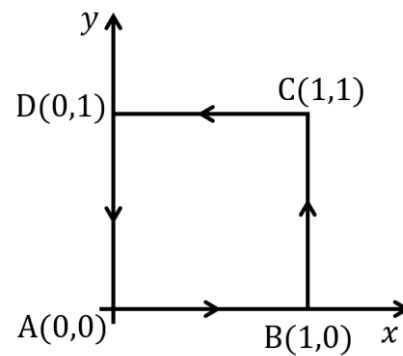

$\oint_{\Gamma} \vec{F} \cdot d\vec{l}$ denotes the line integral of \vec{F} along the closed path Γ . Which of the following option is/are true?

MSQ

- (A) $\oint_{\Gamma} \vec{F} \cdot d\vec{l} = 0$
- (B) \vec{F} is non-conservative
- (C) $\vec{\nabla} \cdot \vec{F} = 0$
- (D) \vec{F} can be written as the gradient of a scalar field

Q.46 Two point charges of charge $+q$ each are placed a distance $2d$ apart. A grounded solid conducting sphere of radius a is placed midway between them. Assume $a^2 \ll d^2$. Which of the following statement is/are true?

- (A) If $a > \frac{d}{3}$, the net force acting on the charges is directed towards each other
- (B) The potential at the surface of the sphere is zero
- (C) Total induced charge on the sphere is $\left(-\frac{2aq}{d}\right)$
- (D) The potential at the center of the sphere is non-zero

Q.47 A particle of mass m is moving in the potential

$$V(x) = \begin{cases} V_0 + \frac{1}{2}m\omega_0^2x^2, & x > 0, \\ \infty, & x \leq 0, \end{cases}$$

Figures P, Q, R and S show different combinations of the values of ω_0 and V_0 .

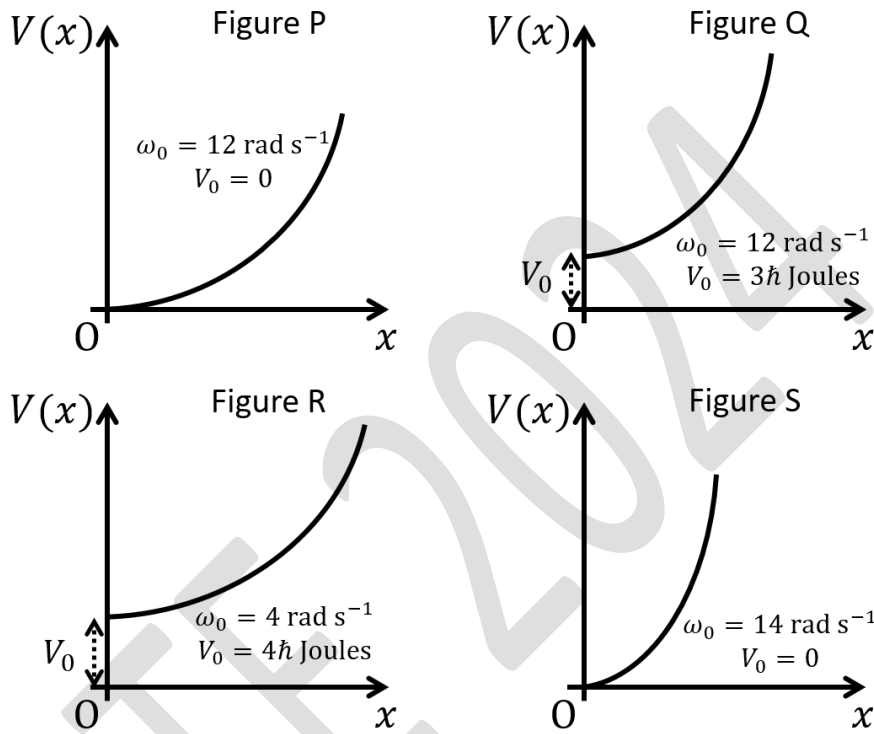

$E_j^{(P)}, E_j^{(Q)}, E_j^{(R)}$ and $E_j^{(S)}$ with $j = 0, 1, 2, \dots$, are the eigen-energies of the j -th level for the potentials shown in figures P, Q, R and S, respectively. Which of the statement is/are true?

- (A) $E_0^{(P)} = E_0^{(Q)}$
- (B) $E_0^{(Q)} = E_0^{(S)}$
- (C) $E_0^{(P)} = E_1^{(R)}$
- (D) $E_0^{(R)} \neq E_0^{(Q)}$

Q.48 The non-relativistic Hamiltonian for a single electron atom is

$$H_0 = \frac{p^2}{2m} - V(r)$$

where $V(r)$ is the Coulomb potential and m is the mass of the electron. Considering the spin-orbit interaction term

$$H' = \frac{1}{2m^2c^2} \frac{1}{r} \frac{dV}{dr} \vec{L} \cdot \vec{S}$$

added to H_0 , which of the following statement is/are true?

- (A) H' commutes with L^2
- (B) H' commutes with L_z and S_z
- (C) For a given value of principal quantum number n and orbital angular momentum quantum number l , there are $2(2l + 1)$ degenerate eigenstates of H_0
- (D) H_0, L^2, S^2, L_z and S_z have a set of simultaneous eigenstates

Q.49 Decays of mesons and baryons can be categorized as weak, strong and electromagnetic decays depending upon the interactions involved in the processes. Which of the following option is/are true?

- (A) $\pi^0 \rightarrow \gamma\gamma$ is a weak decay
- (B) $\Lambda^0 \rightarrow \pi^0 + p$ is an electromagnetic decay
- (C) $K^0 \rightarrow \pi^+ + \pi^-$ is a weak decay
- (D) $\Delta^{++} \rightarrow p + \pi^+$ is a strong decay

- Q.50 An extrinsic semiconductor shown in figure carries a current of 2 mA along its length parallel to $+x$ axis.

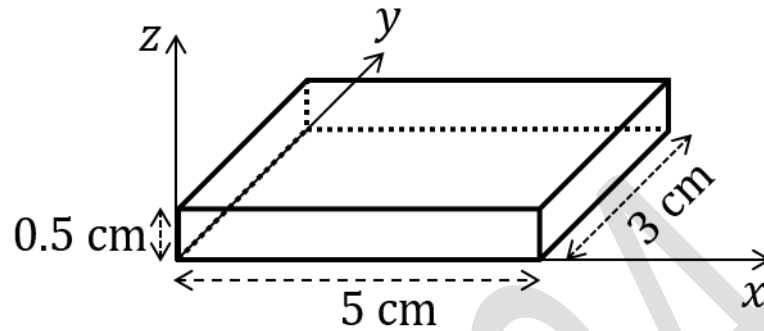

When the majority charge carrier concentration is $12.5 \times 10^{13} \text{ cm}^{-3}$ and the sample is exposed to a constant magnetic field applied along the $+z$ direction, a Hall voltage of 20 mV is measured with the negative polarity at $y = 0$ plane. Take the electric charge as $1.6 \times 10^{-19} \text{ C}$. The concentration of minority charge carrier is negligible. Which of the following statement is/are true?

- (A) The majority charge carrier is electron
- (B) The magnitude of the applied magnetic field is 1 Tesla
- (C) The electric field corresponding to the Hall voltage is in the $+y$ direction
- (D) The magnitude of Hall coefficient is $50,000 \text{ m}^3 \text{ C}^{-1}$

Q.51 A^α and B_β ($\alpha, \beta = 1, 2, 3, \dots, n$) are contravariant and covariant vectors, respectively. By convention, any repeated indices are summed over. Which of the following expression is/are tensors?

(A) $A^\alpha B_\beta$

(B) $\frac{A^\alpha B_\beta}{A^\alpha B_\alpha}$

(C) $\frac{A^\alpha}{B_\beta}$

(D) $A^\alpha + B_\beta$

GATE 2024

Q.52 The temperature T dependence of magnetic susceptibility χ (Column I) of certain magnetic materials (Column II) are given below. Which of the following option is/are correct?

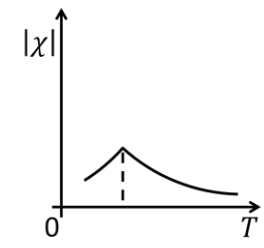
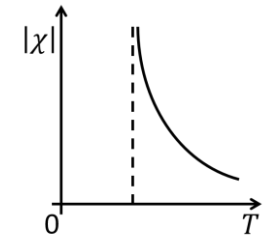
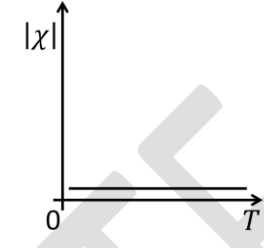
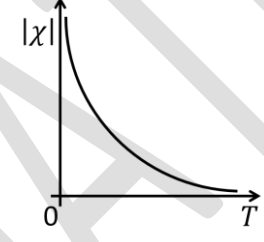
Column I	Column II
(1) 	(P) Diamagnetic
(2) 	(Q) Paramagnetic
(3) 	(R) Ferromagnetic
(4) 	(S) Antiferromagnetic

- (A) 2 – P, 4 – Q, 3 – S
- (B) 4 – P, 1 – Q, 2 – R
- (C) 4 – Q, 2 – R, 1 – S
- (D) 3 – P, 4 – Q, 2 – R

Q.53 The curves P and Q schematically show the variation of X-ray intensity with wavelength at two different accelerating voltages for a given target material. In the figure $\lambda_1 = 0.25 \text{ \AA}$, $\lambda_2 = 0.5 \text{ \AA}$, $\lambda_3 = 1.0 \text{ \AA}$, and $\lambda_4 = 2.25 \text{ \AA}$. Take Planck's constant as $6.6 \times 10^{-34} \text{ Js}$, speed of light as $3 \times 10^8 \text{ ms}^{-1}$ and elementary charge as $1.6 \times 10^{-19} \text{ C}$.

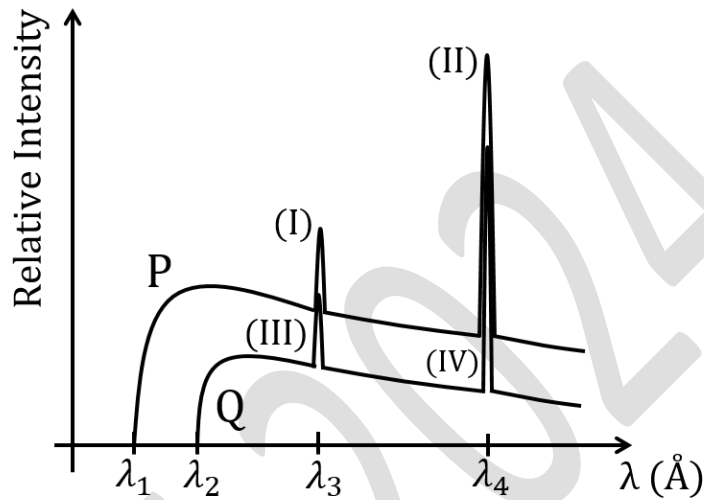

Which of the following statement is/are true?

- (A) The accelerating potential corresponding to curve P is greater than that of curve Q
- (B) The accelerating potential applied to obtain curve Q is 24750 V
- (C) Peaks (II) and (IV) correspond to radiative transitions from L to K shells
- (D) Peaks (I) and (III) correspond to radiative transitions from N to K shells

Q.54 Apart from the acoustic modes, 9 optical modes are identified from the measurements of phonon dispersions of a solid with chemical formula A_nB_m , where A and B denote the atomic species, and n and m are integers. Which of the following combination of n and m is/are possible?

(A) $n = 1, m = 1$

(B) $n = 2, m = 2$

(C) $n = 3, m = 1$

(D) $n = 4, m = 4$

GATE 2024

- Q.55 An oscillating electric dipole of moment $\vec{d}(t) = d_0 \cos(\omega t) \hat{z}$ is placed at origin as shown in figure.

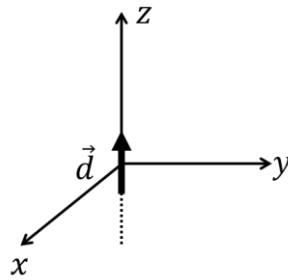

Consider a point $P(r, \theta, \phi)$ at a very large distance from the dipole. Here r, θ and ϕ are spherical polar coordinates. Which of the following statement is/are true for intensity of radiation?

- (A) Intensity is zero if P is on the z axis
- (B) Intensity is zero at $P\left(r = R, \theta = \frac{\pi}{2}, \phi = \frac{\pi}{4}\right)$
- (C) Intensity at $P\left(r = R, \theta = \frac{\pi}{2}, \phi = \frac{\pi}{4}\right)$ is greater than that at $P\left(r = R, \theta = \frac{\pi}{4}, \phi = \frac{\pi}{4}\right)$
- (D) Intensity at $P\left(r = R, \theta = \frac{\pi}{2}, \phi = \frac{\pi}{4}\right)$ is equal to that at $P\left(r = R, \theta = \frac{\pi}{4}, \phi = \frac{\pi}{4}\right)$

Q.56 The Fourier transform and its inverse transform are respectively defined as $\tilde{f}(\omega) = \frac{1}{\sqrt{2\pi}} \int_{-\infty}^{+\infty} f(x)e^{i\omega x} dx$ and $f(x) = \frac{1}{\sqrt{2\pi}} \int_{-\infty}^{+\infty} \tilde{f}(\omega)e^{-i\omega x} d\omega$. Consider two functions f and g . Another function $f * g$ is defined as

$$(f * g)(x) = \frac{1}{\sqrt{2\pi}} \int_{-\infty}^{+\infty} f(y)g(x - y)dy$$

Which of the following relation is/are true?

Note: Tilde (\sim) denotes the Fourier transform.

(A) $f * g = g * f$

(B) $\widetilde{f * g} = \widetilde{g * f}$

(C) $\widetilde{f * g} = \widetilde{f} \widetilde{g}$

(D) $\widetilde{f * g} = \tilde{f} \tilde{g}$

Q.57 A material behaves as a superconductor below a critical temperature T_c and as a normal conductor above T_c . A magnetic field $\vec{B} = B\hat{z}$ is applied when $T > T_c$. The material is then cooled below T_c in the presence of \vec{B} . Which of the following figure represent the correct configuration of magnetic field lines?

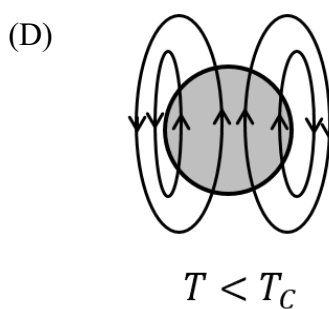
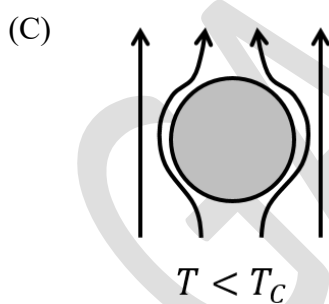
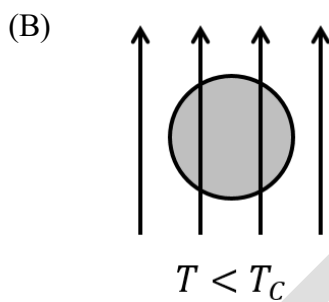
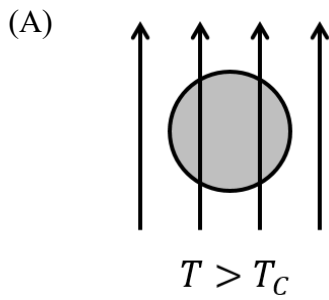

Q.58 A typical biasing of a silicon transistor is shown in figure.

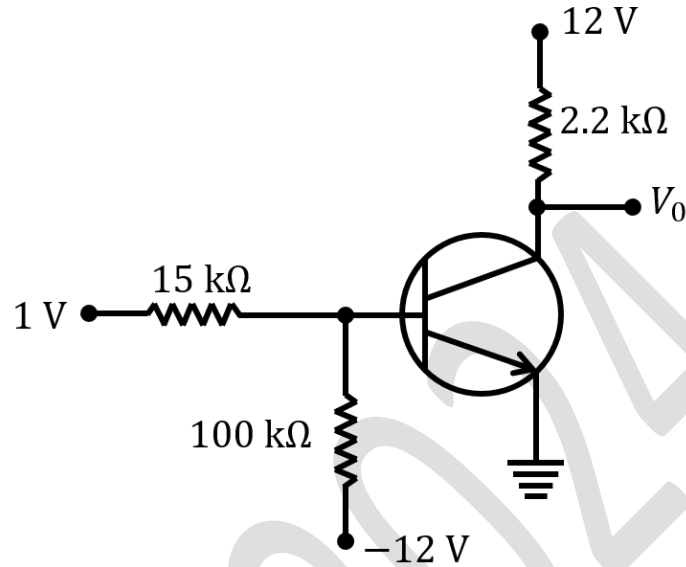

The value of common-emitter current gain β for the transistor is 100. Ignore reverse saturation current. The output voltage V_0 (in V) is _____ (in integer).

Q.59 The canonical partition function of an ideal gas is

$$Q(T, V, N) = \frac{1}{N!} \left[\frac{V}{(\lambda(T))^3} \right]^N$$

where T, V, N and $\lambda(T)$ denote temperature, volume, number of particles, and thermal de Broglie wavelength, respectively. Let k_B be the Boltzmann constant and μ be the chemical potential. Take $\ln(N!) = N \ln(N) - N$.

If the number density $\left(\frac{N}{V}\right)$ is $2.5 \times 10^{25} \text{ m}^{-3}$ at a temperature T , then $\frac{e^{\mu/(k_B T)}}{(\lambda(T))^3} \times 10^{-25}$ is _____ m^{-3} (rounded off to one decimal place).

Q.60 Lagrangian of a particle of mass m is $L = \frac{1}{2}m\dot{x}^2 - \lambda x^4$, where λ is a positive constant. If the particle oscillates with total energy E , then the time period of oscillations is

$$a \int_0^{\left(\frac{E}{\lambda}\right)^{\frac{1}{4}}} \frac{dx}{\sqrt{\left(\frac{2}{m}\right)(E - \lambda x^4)}}$$

The value of a is _____ (in integer).

Q.61 A particle of mass m in an infinite potential well of width a is subjected to a perturbation, $V' = \frac{h^2}{40ma^2}$ as shown in figure, where h is Planck's constant.

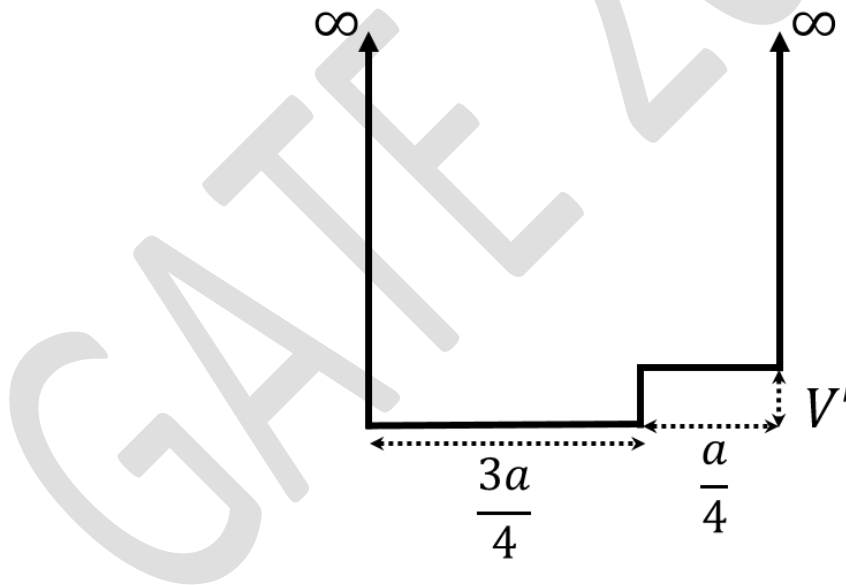

The first order energy shift of the fourth energy eigenstate due to this perturbation is

$$\left(\frac{h^2}{Nma^2}\right)$$

The value of N is _____ (in integer).

- Q.62 Consider a three-dimensional system of non-interacting bosons with zero chemical potential. The energy of the system $\epsilon \propto k^2$, where k is the wavevector. The low temperature specific heat of the system at constant volume depends on the temperature as $C_V \propto T^{\frac{n}{2}}$. The value of n is _____ (in integer).

- Q.63 Consider the operational amplifier circuit shown in figure.

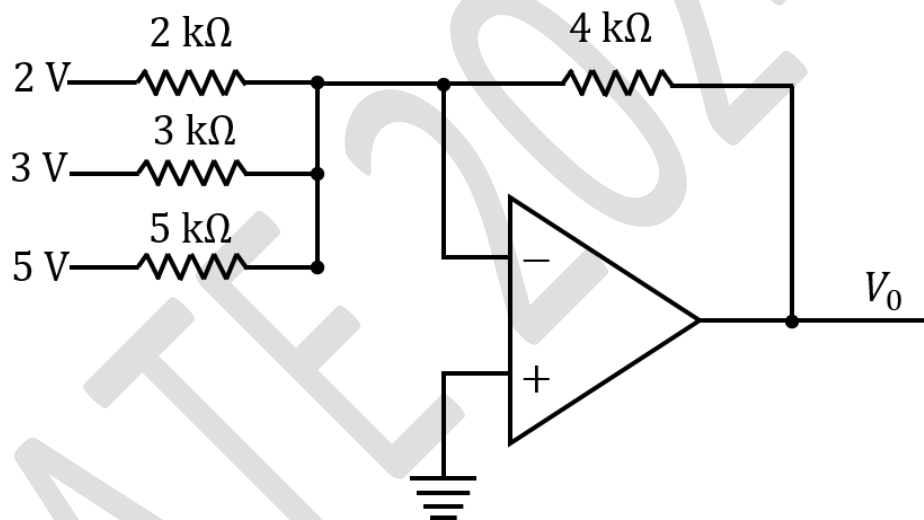

The output voltage V_0 is _____ V (in integer).

- Q.64 An electron in the Coulomb field of a proton is in the following state of coherent superposition of orthonormal states ψ_{nlm}

$$\Psi = \frac{1}{3}\psi_{100} + \frac{1}{\sqrt{3}}\psi_{210} - \frac{\sqrt{5}}{3}\psi_{320}$$

Let E_1, E_2 , and E_3 represent the first three energy levels of the system. A sequence of measurements is done on the same system at different times. Energy is measured first at time t_1 and the outcome is E_2 . Then total angular momentum is measured at time $t_2 > t_1$ and finally energy is measured again at $t_3 > t_2$. The probability of finding the system in a state with energy E_2 after the final measurement is $P/9$. The value of P is _____ (in integer).

- Q.65 According to the nuclear shell model, the absolute value of the difference in magnetic moments of $^{15}_8\text{O}$ and $^{15}_7\text{N}$, in the units of nuclear magneton (μ_N) is $a/3$. The magnitude of a is _____ (in integer).