



collegebatch.com

click to campus

## GATE 2024 Environmental Science and Engineering (ES) Question Paper

Graduate Aptitude Test in Engineering (GATE)

Download more GATE Previous Year Question Papers: [Click Here](#)

**General Aptitude (GA)**

**Q.1 – Q.5 Carry ONE mark Each**

Q.1	If '→' denotes increasing order of intensity, then the meaning of the words [sick → infirm → moribund] is analogous to [silly → _____ → daft]. Which one of the given options is appropriate to fill the blank?
(A)	frown
(B)	fawn
(C)	vein
(D)	vain

Q.2

The 15 parts of the given figure are to be painted such that no two adjacent parts with shared boundaries (excluding corners) have the same color. The minimum number of colors required is

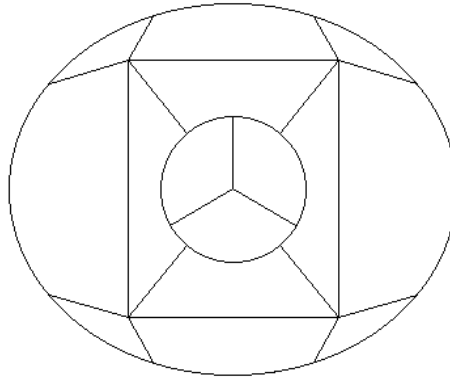

(A)

4

(B)

3

(C)

5

(D)

6

Q.3	How many 4-digit positive integers divisible by 3 can be formed using only the digits {1, 3, 4, 6, 7}, such that no digit appears more than once in a number?
(A)	24
(B)	48
(C)	72
(D)	12
Q.4	The sum of the following infinite series is $2 + \frac{1}{2} + \frac{1}{3} + \frac{1}{4} + \frac{1}{8} + \frac{1}{9} + \frac{1}{16} + \frac{1}{27} + \dots$
(A)	11/3
(B)	7/2
(C)	13/4
(D)	9/2

Q.5

In an election, the share of valid votes received by the four candidates A, B, C, and D is represented by the pie chart shown. The total number of votes cast in the election were 1,15,000, out of which 5,000 were invalid.

**Share of valid votes**

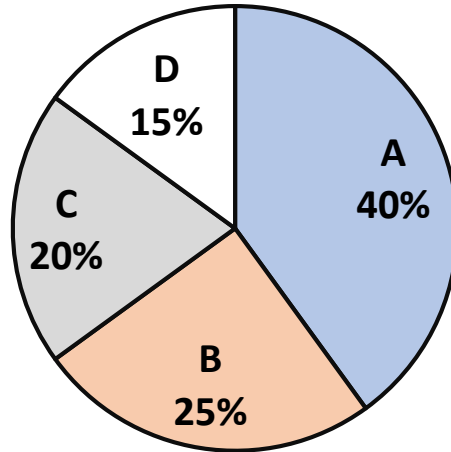

Based on the data provided, the total number of valid votes received by the candidates B and C is

(A) 45,000

(B) 49,500

(C) 51,750

(D) 54,000

**Q.6 – Q.10 Carry TWO marks Each**

Q.6	Thousands of years ago, some people began dairy farming. This coincided with a number of mutations in a particular gene that resulted in these people developing the ability to digest dairy milk.  Based on the given passage, which of the following can be inferred?
(A)	All human beings can digest dairy milk.
(B)	No human being can digest dairy milk.
(C)	Digestion of dairy milk is essential for human beings.
(D)	In human beings, digestion of dairy milk resulted from a mutated gene.
Q.7	The probability of a boy or a girl being born is $\frac{1}{2}$ . For a family having only three children, what is the probability of having two girls and one boy?
(A)	$\frac{3}{8}$
(B)	$\frac{1}{8}$
(C)	$\frac{1}{4}$
(D)	$\frac{1}{2}$

Q.8

Person 1 and Person 2 invest in three mutual funds A, B, and C. The amounts they invest in each of these mutual funds are given in the table.

	Mutual fund A	Mutual fund B	Mutual fund C
Person 1	₹10,000	₹20,000	₹20,000
Person 2	₹20,000	₹15,000	₹15,000

At the end of one year, the total amount that Person 1 gets is ₹500 more than Person 2. The annual rate of return for the mutual funds B and C is 15% each. What is the annual rate of return for the mutual fund A?

(A) 7.5%

(B) 10%

(C) 15%

(D) 20%

Q.9

Three different views of a dice are shown in the figure below.



The piece of paper that can be folded to make this dice is

(A)

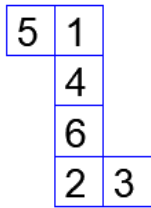

(B)

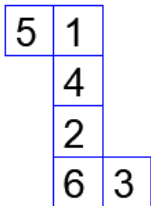

(C)

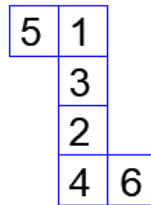

(D)

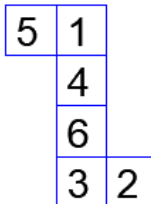



Q.10	Visualize two identical right circular cones such that one is inverted over the other and they share a common circular base. If a cutting plane passes through the vertices of the assembled cones, what shape does the outer boundary of the resulting cross-section make?
(A)	A rhombus
(B)	A triangle
(C)	An ellipse
(D)	A hexagon

GATE 2024

**Q.11 – Q.35 Carry ONE mark Each**

Q.11	Ten cards in a pack are numbered as 1, 2, 3, . . .10. The probability of drawing a card with an even number or a number which is a multiple of 5 from the pack is _____.
(A)	4/10
(B)	6/10
(C)	2/10
(D)	3/10
Q.12	Hardness in water is <b>NOT</b> caused by _____.
(A)	$Ca^{2+}$
(B)	$Si^{2+}$
(C)	$Mg^{2+}$
(D)	$CO_3^{2-}$

Q.13	The maximum coordination number of $Sn^{4+}$ is _____.
(A)	4
(B)	8
(C)	6
(D)	2
Q.14	Rod shaped bacterial cells are called _____.
(A)	<i>Bacilli</i>
(B)	<i>Cocci</i>
(C)	<i>Spirilla</i>
(D)	<i>Diplococci</i>

Q.15	Tuberculosis is predominantly caused by _____.
(A)	<i>Entamoeba histolytica</i>
(B)	<i>Salmonella typhi</i>
(C)	<i>Mycobacterium bovis</i>
(D)	<i>Bacillus cereus</i>
Q. 16	Which one of the following conversions belongs to nonsymbiotic nitrogen fixation?
(A)	Atmospheric nitrogen to ammonia by <i>Rhizobium</i> bacteria in nodules attached to roots of legumes
(B)	Atmospheric nitrogen to ammonia by <i>Azotobacter</i> species
(C)	Nitrate to gaseous nitrogen under anaerobic conditions
(D)	Nitrate to ammonia under aerobic conditions

Q.17	Crown corrosion of reinforced cement concrete sewer is caused by _____.										
(A)	sulfur oxidizing bacteria										
(B)	iron oxidizing bacteria										
(C)	denitrifying bacteria										
(D)	fermentative bacteria										
Q.18	<p>The processes of removal of particles in a rapid sand filter with their description is given in the table.</p> <table border="1" data-bbox="328 949 1417 1290"> <thead> <tr> <th>Process</th> <th>Description</th> </tr> </thead> <tbody> <tr> <td>(i) Straining</td> <td>P: Removes only particles in the water large enough to get caught in the pores of the filter</td> </tr> <tr> <td>(ii) Sedimentation</td> <td>Q: Larger and heavier particles do not follow the fluid streamline around the sand grain and settle on the grain</td> </tr> <tr> <td>(iii) Interception</td> <td>R: Particles that do follow the streamline, but are too large and are caught because they brush up against the sand grains</td> </tr> <tr> <td>(iv) Diffusion</td> <td>S: Very small particles are experiencing Brownian motion and may collide with the sand grains by chance</td> </tr> </tbody> </table> <p>Select the correct match.</p>	Process	Description	(i) Straining	P: Removes only particles in the water large enough to get caught in the pores of the filter	(ii) Sedimentation	Q: Larger and heavier particles do not follow the fluid streamline around the sand grain and settle on the grain	(iii) Interception	R: Particles that do follow the streamline, but are too large and are caught because they brush up against the sand grains	(iv) Diffusion	S: Very small particles are experiencing Brownian motion and may collide with the sand grains by chance
Process	Description										
(i) Straining	P: Removes only particles in the water large enough to get caught in the pores of the filter										
(ii) Sedimentation	Q: Larger and heavier particles do not follow the fluid streamline around the sand grain and settle on the grain										
(iii) Interception	R: Particles that do follow the streamline, but are too large and are caught because they brush up against the sand grains										
(iv) Diffusion	S: Very small particles are experiencing Brownian motion and may collide with the sand grains by chance										
(A)	i- S; ii-P; iii-Q; iv-R										
(B)	i-Q; ii-R; iii-S; iv-P										
(C)	i-R; ii- S; iii- P; iv-Q										
(D)	i-P; ii-Q; iii-R; iv-S										

**Environmental Science and Engineering (ES)**

Q.19	The environmental temperature increases by $6\text{ }^{\circ}\text{C}/\text{km}$ with height at a particular location. The stability condition of the atmosphere at the location is _____.
(A)	stable
(B)	unstable
(C)	inversion
(D)	neutral
Q.20	As per the United Nations agenda for sustainable development adopted in September 2015, the number of Sustainable Development Goals (SDGs) are _____ and the proposed target year to achieve them is _____.
(A)	15; 2035
(B)	17; 2030
(C)	20; 2050
(D)	18; 2047

Q.21	Which one of the following is <b>NOT</b> a greenhouse gas?
(A)	CO <sub>2</sub>
(B)	CH <sub>4</sub>
(C)	H <sub>2</sub> S
(D)	H <sub>2</sub> O
Q.22	As per the United Nations Environmental Program (UNEP) guidelines 2004, the maximum size of microplastics is _____.
(A)	10 mm
(B)	5 mm
(C)	10 μm
(D)	5 μm

Q23	The costliest functional element in an urban centralized Municipal Solid Waste management infrastructure for a typical Indian Tier I city is _____.
(A)	biological treatment
(B)	collection and transport
(C)	disposal in a sanitary landfill
(D)	thermal treatment
Q.24	The eigen values of the matrix $\begin{bmatrix} 4 & 3 \\ 3 & 4 \end{bmatrix}$ are
(A)	1
(B)	2
(C)	7
(D)	4



Q. 25	If $\mathbf{X}$ is a vector, and $\mathbf{A}$ and $\mathbf{B}$ are linear operators; then the correct mathematical relationship(s) is/are
(A)	$(\mathbf{A}+\mathbf{B})\mathbf{X} = \mathbf{A}\mathbf{X} + \mathbf{B}\mathbf{X}$
(B)	$(\lambda\mathbf{A})\mathbf{X} = \lambda(\mathbf{A}\mathbf{X})$
(C)	$(\mathbf{A}\mathbf{B})\mathbf{X} = \mathbf{A}(\mathbf{B}\mathbf{X})$
(D)	$(\mathbf{A}+\mathbf{B})\mathbf{X} = \mathbf{A}^T\mathbf{X}+\mathbf{B}^T\mathbf{X}$
Q.26	In the context of fluid flow, which of the following statement(s) is/are correct?
(A)	<i>Streamline</i> is a line, tangent to which at any point gives the direction of the velocity vector
(B)	<i>Streakline</i> is the actual path traversed by a given fluid particle in an unsteady flow
(C)	<i>Streakline</i> and <i>streamline</i> are same for a steady flow
(D)	<i>Pathline</i> and <i>streamline</i> are same for a steady flow

Q.27	In a rectangular open channel, the flow is critical, and the flow depth is 2 m. Select the correct statement(s)
(A)	Specific energy for the flow is 3.0 m
(B)	Specific energy for the flow is 2.0 m
(C)	Froude number is 1.0
(D)	Froude number is 1.5
Q.28	With respect to particle settling in wastewater treatment systems; the correct statement(s) is/are
(A)	Settling in grit chamber and primary sedimentation tanks are examples of Type-I settling
(B)	Settling in primary sedimentation tank and secondary sedimentation tank are examples of Type-II settling
(C)	Settling in grit chamber is an example of Type-I settling, whereas settling in primary sedimentation tank is an example of Type-II settling
(D)	Settling in secondary sedimentation tank is an example of Type-III settling, whereas settling in primary sedimentation tank is an example of Type-II settling

Q.29	The equipment that can be used to control particulate air pollution in an industrial unit is/are
(A)	Electrostatic precipitator
(B)	Cyclone separator
(C)	Gravity settler
(D)	Incinerator
Q.30	Which is/are the secondary air pollutant(s)?
(A)	O <sub>3</sub>
(B)	HNO <sub>3</sub>
(C)	CO <sub>2</sub>
(D)	H <sub>2</sub> SO <sub>4</sub>

Q.31	As per the Hazardous Waste (Management and Handling) Rules, 2016, of India, which is/are the characteristic(s) that must be exhibited by a waste to be classified as a “characteristic” hazardous waste?
(A)	Ignitability
(B)	Reactivity
(C)	Radioactivity
(D)	Toxicity
Q. 32	$f(x) = x^3 - 4.5x^2 - 12x$ has a local maximum at $x =$ _____ (an integer value) in the range $x = -2$ to $+2$ .
Q. 33	Consider the equation $\frac{dy}{dx} - x^2 + e^x = 0$ ; with $y=1$ at $x=0$ . The value of $y$ at $x=1$ is _____ (rounded off to 2 decimal places). Take the value of $e$ (base of natural logarithm) as 2.7.
Q.34	A municipal solid waste digester generates 1000 kg of methane gas. The volume of the tank needed to store this gas at 30 °C and 3 atmospheric pressure is _____ liters (an integer value). Use $R=0.082$ L-atm/mole-K, Atomic weights of C=12, and H=1

Q.35	<p>A Class-A pan was setup adjacent to a lake for measuring evaporation losses in the lake. The depth of water in the pan at the beginning of a certain week was 250 mm. In that week, there was a rainfall event with 10 mm depth. Water depth in the pan at the end of the week was 240 mm. The pan coefficient is 0.8.</p> <p>The estimated lake evaporation during the week was _____ mm (<i>an integer value</i>).</p>

GATE 2024

**Q.36 – Q.65 Carry TWO marks Each**

Q.36	<p>A population (with mean <math>\mu</math>) follows normal distribution. Ten samples (N) are drawn at random with a mean value of “x” and standard deviation of “S”. Following table provides the confidence limits, C(t) of the cumulative probability function for Student’s t – distribution two-tailed test with degree of freedom, D.</p> <p>Which one of the following expression is correct for testing the null hypothesis <math>H_0: \mu = 0</math> at 10% significance level?</p> <table border="1" style="margin: 10px auto; border-collapse: collapse; text-align: center;"> <thead> <tr> <th rowspan="2">D</th> <th colspan="3">C(t)</th> </tr> <tr> <th>0.9</th> <th>0.95</th> <th>0.975</th> </tr> </thead> <tbody> <tr> <td>9</td> <td>1.38</td> <td>1.83</td> <td>2.26</td> </tr> <tr> <td>10</td> <td>1.37</td> <td>1.81</td> <td>2.23</td> </tr> <tr> <td>11</td> <td>1.36</td> <td>1.80</td> <td>2.20</td> </tr> </tbody> </table>	D	C(t)			0.9	0.95	0.975	9	1.38	1.83	2.26	10	1.37	1.81	2.23	11	1.36	1.80	2.20
D	C(t)																			
	0.9	0.95	0.975																	
9	1.38	1.83	2.26																	
10	1.37	1.81	2.23																	
11	1.36	1.80	2.20																	
(A)	$-1.81 < \frac{x}{\frac{S}{\sqrt{N-1}}} < 1.81$																			
(B)	$-1.83 < \frac{x}{\frac{S}{\sqrt{N-1}}} < 1.83$																			
(C)	$-1.37 < \frac{x}{\frac{S}{\sqrt{N-1}}} < 1.37$																			
(D)	$-2.23 < \frac{x}{\frac{S}{\sqrt{N-1}}} < 2.23$																			

Q.37	Which one is the solution $y(x)$ for the following ordinary differential equation and the specified boundary conditions?
	$\frac{d^2y}{dx^2} - 3\frac{dy}{dx} + 2y = 2e^{-x}; y(0) = 2; \left(\frac{dy}{dx}\right)_{x=0} = 1$
(A)	$y(x) = \frac{1}{3}e^{-x} - 2e^x - \frac{1}{3}e^{2x}$
(B)	$y(x) = \frac{1}{3}e^x + 2e^x - \frac{1}{3}e^{2x}$
(C)	$y(x) = \frac{1}{3}e^{-x} + 2e^{-x} - \frac{1}{3}e^{2x}$
(D)	$y(x) = \frac{1}{3}e^{-x} + 2e^x - \frac{1}{3}e^{2x}$
Q.38	A saturated $\text{CaCO}_3$ stock solution is existing at $25^\circ\text{C}$ . In one experiment (i) 25 g $\text{Na}_2\text{CO}_3$ is added to the stock solution. In another experiment (ii) 25 g $\text{Na}_2\text{SO}_4$ is added to the stock solution. Select the correct statement from the following.
(A)	Addition of (i) increases the concentration of $\text{Ca}^{2+}$ and addition of (ii) decreases the concentration of $\text{Ca}^{2+}$
(B)	Addition of (i) decreases the concentration of $\text{Ca}^{2+}$ and addition of (ii) increases the concentration of $\text{Ca}^{2+}$
(C)	Addition of (i) and (ii) increase the concentration of $\text{Ca}^{2+}$
(D)	Addition of (i) and (ii) decrease the concentration of $\text{Ca}^{2+}$

Q.39	Consider second order kinetics ( $r_c = -kC^2$ ) under steady state condition. The ratio of volume of a complete mixed reactor (CMR) to that of a plug flow reactor (PFR) to achieve 90% reduction in the concentration is _____.  Inlet concentrations in both the reactors are same.
(A)	10.0
(B)	1.0
(C)	0.1
(D)	2.3
<b>GATE 2024</b>	

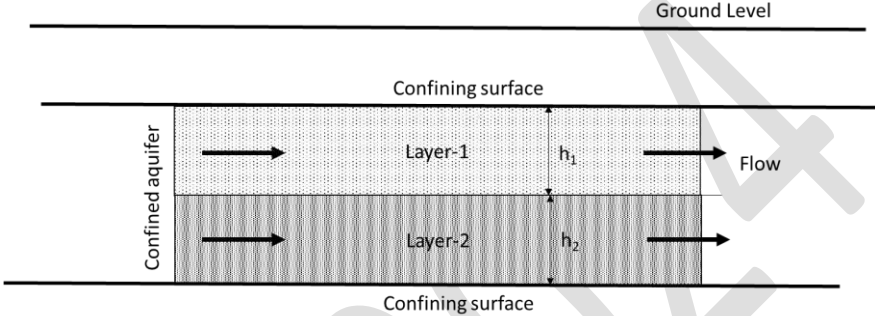

<p>Q.40</p>	<p>Consider two horizontal layers of an aquifer as shown in figure. Each layer is isotropic and homogeneous. Flow is parallel to the stratification. Thickness and horizontal hydraulic conductivity of layer-1 are <math>h_1</math> and <math>K_1</math>, respectively. Thickness and horizontal hydraulic conductivity of layer-2 are <math>h_2</math> and <math>K_2</math>, respectively, where <math>h_1</math> is not equal to <math>h_2</math>. The equivalent horizontal conductivity <math>K_x</math> for the aquifer system is given by _____.</p>
	
(A)	$K_x = \frac{K_1 \cdot h_1 + K_2 \cdot h_2}{h_1 + h_2}$
(B)	$K_x = \frac{K_1 + K_2}{2}$
(C)	$K_x = \frac{K_1 \cdot h_2 + K_2 \cdot h_1}{h_1 + h_2}$
(D)	$K_x = \sqrt{K_1 \cdot K_2}$

Q.41	<p>A gravity settling chamber of height '<math>H</math>' and length '<math>L</math>' is designed to control particulate air pollution. In the chamber, the horizontal velocity of air flow is '<math>V_h</math>' and terminal settling velocity of the target particle is '<math>V_t</math>'.</p> <p>Which one of the following expressions is the correct concept used to calculate the minimum size of the target particle that will be removed with 100% efficiency?</p>
(A)	$\frac{V_t}{L} = \frac{V_h}{H}$
(B)	$V_h \times V_t = L \times H$
(C)	$V_h = V_t \times L \times H$
(D)	$\frac{V_t}{H} = \frac{V_h}{L}$
Q.42	<p>Consider the function <math>f(x) = \ln(\sin(x))</math>.</p> <p>Expand <math>f(x+h)</math> using Taylor's series. In this context, the correct statement(s) is/are</p>
(A)	Second term in the Taylor's series i.e., the term which includes $h$ is: $h \cdot \ln(\sin(x))$
(B)	First term is $\ln(\sin(x))$
(C)	Third term in the Taylor's series i.e., the term which includes $h^2$ is: $\frac{-h^2}{2(\sin(x))^2}$
(D)	Third term in the Taylor's series i.e., the term which includes $h^2$ is: $\frac{2h^2}{(\sin(x))^2}$

<p>Q. 43</p>	<p>Enzymes with the class of enzymes are listed in the table.</p> <table border="1" data-bbox="363 293 1358 804"> <thead> <tr> <th data-bbox="363 293 860 396">Enzyme</th> <th data-bbox="860 293 1358 396">Class of Enzyme</th> </tr> </thead> <tbody> <tr> <td data-bbox="363 396 860 499">(a) Lactate dehydrogenase</td> <td data-bbox="860 396 1358 499">(i) Isomerases</td> </tr> <tr> <td data-bbox="363 499 860 602">(b) Alanine racemase</td> <td data-bbox="860 499 1358 602">(ii) Transferases</td> </tr> <tr> <td data-bbox="363 602 860 705">(c) Lipase</td> <td data-bbox="860 602 1358 705">(iii) Oxidoreductases</td> </tr> <tr> <td data-bbox="363 705 860 804">(d) Hexokinase</td> <td data-bbox="860 705 1358 804">(iv) Hydrolases</td> </tr> </tbody> </table> <p>Select the correct match(es)</p>	Enzyme	Class of Enzyme	(a) Lactate dehydrogenase	(i) Isomerases	(b) Alanine racemase	(ii) Transferases	(c) Lipase	(iii) Oxidoreductases	(d) Hexokinase	(iv) Hydrolases
Enzyme	Class of Enzyme										
(a) Lactate dehydrogenase	(i) Isomerases										
(b) Alanine racemase	(ii) Transferases										
(c) Lipase	(iii) Oxidoreductases										
(d) Hexokinase	(iv) Hydrolases										
(A)	(a) - (iii); (b) - (i)										
(B)	(c) - (iv); (d) - (ii)										
(C)	(a) - (ii); (b) - (iv)										
(D)	(c) - (iii); (d) - (i)										
Q.44	With reference to disinfection, which of the following statement(s) is/are <b>CORRECT</b> ?										
(A)	Ethanol damages lipid structures in the bacterial cell membrane.										
(B)	Mercuric chloride inactivates cellular enzymes containing sulfhydryl groups.										
(C)	Glutaraldehyde inactivates protein.										
(D)	Isopropyl alcohol cannot be used as a disinfectant.										

Q.45	Which of the following statement(s) is/are <b>CORRECT</b> ?
(A)	DNA is composed of nucleotides.
(B)	Five types of nitrogenous bases occur in DNA.
(C)	Each phosphate is attached to two deoxyribose units in a single strand of DNA.
(D)	The ratio of adenine to guanine is always 1:1 in a double stranded DNA.
Q.46	The Streeter–Phelp’s oxygen sag equation for a river is based on a few assumptions. The correct assumption(s) is/are
(A)	At any instant the deoxygenation rate is directly proportional to the amount of oxidizable organic material present.
(B)	At any instant the deoxygenation rate is inversely proportional to the amount of oxidizable organic material present.
(C)	The reoxygenation rate is directly proportional to the dissolved oxygen deficit.
(D)	The reoxygenation rate and deoxygenation rate are directly proportional to the saturation concentration of dissolved oxygen.

Q.47	Water is flowing <b>FULL</b> through a rectangular tunnel of size 3 m (width) $\times$ 2 m (height). The average velocity of flow is 1 m/s. The frictional head loss is observed to be 1 m per km. Consider acceleration due to gravity ( $g$ ) as $10 \text{ m/s}^2$ . The correct statement(s) is/are
(A)	Hydraulic radius is 0.6 m
(B)	Darcy-Weisbach friction factor is 0.048
(C)	Hydraulic radius is 2 m
(D)	Darcy-Weisbach friction factor is 0.024

<p>Q.48</p>	<p>Based on the ISO 14040 methodology for Life Cycle Assessment, match the terms with the descriptions in the table.</p> <table border="1" data-bbox="288 331 1390 898"> <thead> <tr> <th data-bbox="288 331 660 432">Term</th> <th data-bbox="660 331 1390 432">Description</th> </tr> </thead> <tbody> <tr> <td data-bbox="288 432 660 575">(a) Goal and Scope</td> <td data-bbox="660 432 1390 575">(i) Based on the product or system, the comparative unit must be carefully defined and be same for all scenarios</td> </tr> <tr> <td data-bbox="288 575 660 683">(b) Functional Unit</td> <td data-bbox="660 575 1390 683">(ii) The problem is described, and the objective of the study are defined</td> </tr> <tr> <td data-bbox="288 683 660 790">(c) Life Cycle Inventory</td> <td data-bbox="660 683 1390 790">(iii) Evaluates the environmental implications due to the inventorized emissions</td> </tr> <tr> <td data-bbox="288 790 660 898">(d) Impact Assessment</td> <td data-bbox="660 790 1390 898">(iv) Process based approach and input-output approach</td> </tr> </tbody> </table> <p>The correct match(es) is/are</p>	Term	Description	(a) Goal and Scope	(i) Based on the product or system, the comparative unit must be carefully defined and be same for all scenarios	(b) Functional Unit	(ii) The problem is described, and the objective of the study are defined	(c) Life Cycle Inventory	(iii) Evaluates the environmental implications due to the inventorized emissions	(d) Impact Assessment	(iv) Process based approach and input-output approach
Term	Description										
(a) Goal and Scope	(i) Based on the product or system, the comparative unit must be carefully defined and be same for all scenarios										
(b) Functional Unit	(ii) The problem is described, and the objective of the study are defined										
(c) Life Cycle Inventory	(iii) Evaluates the environmental implications due to the inventorized emissions										
(d) Impact Assessment	(iv) Process based approach and input-output approach										
(A)	(a)-(ii); b-(i);										
(B)	(a)-(iii), b-(i)										
(C)	(c)-(iii), (d)-(iv)										
(D)	(c)-(iv), (d)-(iii)										
<p>Q.49</p>	<p>Consider the equation for a curve, <math>y = f(x) = x^2 + x</math>.</p> <p>The area enclosed by the curve, the <math>x</math>-axis (<math>y = 0</math> line); the vertical lines passing through <math>x = 1</math> and <math>x = 2</math> is _____ (rounded off to 2 decimal places)</p>										
<p>Q.50</p>	<p>The pH of a solution containing 0.1M of acetic acid and 0.05 M of sodium acetate is _____ (rounded off to 2 decimal places).</p> <p>The <math>pK_a</math> value of ionization of acetic acid is 4.76.</p>										

Q.51	The ionic strength of a solution containing 0.01M of $\text{CaCl}_2$ and 0.001M of $\text{Na}_2\text{SO}_4$ is _____ M (rounded off to 3 decimal places).
Q.52	The concentration of Ozone corresponding to a mixing ratio of 120 ppbv at pressure of 1 atmosphere and temperature of $25^\circ\text{C}$ is _____ $\mu\text{g}/\text{m}^3$ (rounded off to 1 decimal place).  Atomic weight of oxygen = 16; $R = 8.314 \text{ J/K-g.mole}$ .
Q.53	One million liters per day (MLD) of wastewater with a soluble BOD of 200 mg/L is treated in an activated sludge process. The BOD of treated wastewater is 20 mg/L. The observed yield coefficient of the biological system is 0.35.  The daily biomass generation in the system is _____ kg (an integer value).
Q.54	An industry discharges 2 million liters per day (MLD) of wastewater with a temperature of $45^\circ\text{C}$ and a pH of 2, whereas the neighboring industry produces 3 MLD of wastewater with a temperature of $30^\circ\text{C}$ and pH of 8. If both the wastewaters are mixed and carried through a pipeline, then the resultant pH of mixed wastewater is _____ (rounded off to 2 decimal places).  Neglect buffering capacity of the system and the temperature effect on pH.

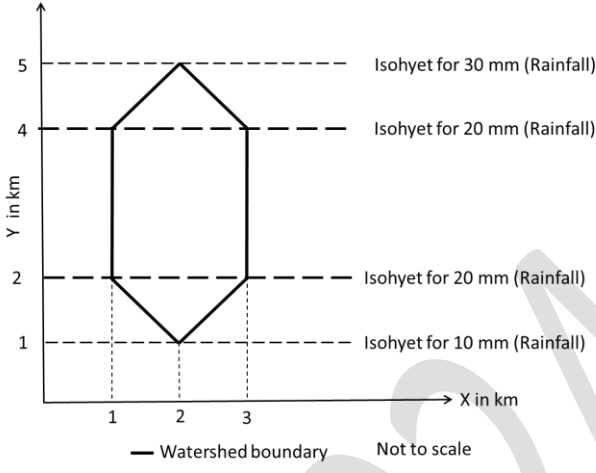
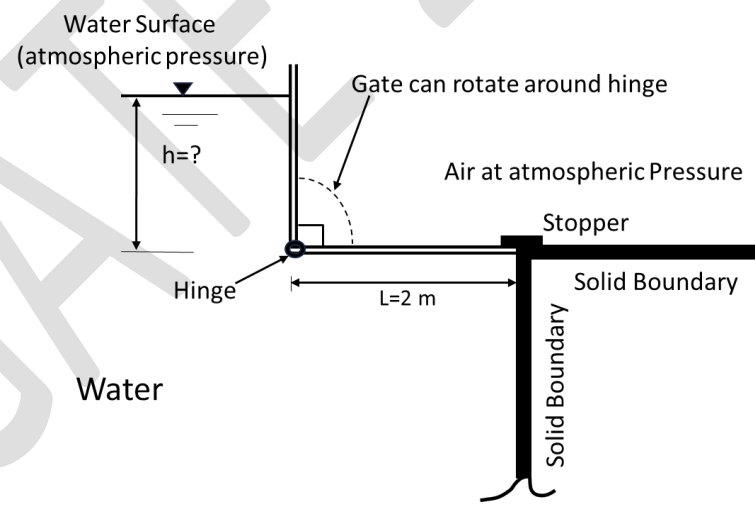
<p>Q.55</p>	<p>Consider a watershed and isohyets as shown in the figure. The average rainfall in the watershed is _____ mm (an <i>integer value</i>).</p>
	
<p>Q.56</p>	<p>With reference to the gate shown in the figure, the gate will start opening automatically when the water level 'h' above the hinge is _____ m (rounded off to 2 decimal places).</p> 



<p>Q.57</p>	<p>In a cyclone separator of radius 25 cm, a particle is travelling with a gas stream at velocity of 18 m/s. The ratio of centrifugal force to the gravitational force acting on the particle is _____ (rounded off to 2 decimal places).</p> <p>Consider acceleration due to gravity (<math>g</math>) as <math>9.8 \text{ m/s}^2</math>.</p>
<p>Q.58</p>	<p>Two sources of noise, adjacent to each other in a room, have sound pressure levels of 30 and 40 decibel (dB). The combined sound pressure level in the room is _____ dB (rounded off to 2 decimal places).</p> <p>Use reference sound pressure as <math>20 \mu\text{Pa}</math>.</p>
<p>Q.59</p>	<p>An industrial stack emits 100 g/s of CO at an effective height of 'H', where the wind speed is 5 m/s. At 3 km distance downwind, the values of dispersion coefficient in y-direction and z-direction are 50 m and 25 m, respectively. The CO concentration at the centerline of the plume at 3 km distance downwind is _____ <math>\text{mg/m}^3</math> (rounded off to 2 decimal places)?</p> <p>Use Gaussian plume model and value of <math>\pi = 3.14</math>. Neglect reactions and the ground effect of plume in the calculations.</p>
<p>Q.60</p>	<p>Two hypothetical organic waste streams A and B are mixed prior to the composting process. Waste-A has 2.16% of C and 1.20% of N. Waste-B has 19.10% of C and 0.14% of N. The quantity of Waste-B that should be mixed with per kg of Waste-A to achieve the desired C:N ratio of 25 is _____ kg (rounded off to 2 decimal places).</p> <p>Assume both the waste streams are completely dry.</p>

Q.61	<p>Food waste, paper waste and plastic waste have typical densities of <math>280 \text{ kg/m}^3</math>, <math>80 \text{ kg/m}^3</math>, and <math>50 \text{ kg/m}^3</math>, respectively. The mixed waste is composed of 70% food waste, 20% paper waste and 10% plastic waste. The density of the mixed waste is _____ <math>\text{kg/m}^3</math> (rounded off to 2 decimal places).</p> <p>Neglect compaction effect.</p>
Q.62	<p>For a biodegradable waste with a chemical formula <math>\text{C}_{50}\text{H}_{100}\text{O}_{40}\text{N}</math>, the maximum theoretical methane production per ton of waste is _____ kg (rounded off to 2 decimal places).</p> <p>Assume 100% anaerobic conversion. Atomic weights of C-12; H-1; O-16; N-14</p>
Q.63	<p>A person consumes 2.5 liters of water per day. The water quality test indicated that the supplied water has a Pb concentration of 0.6 mg/L. If the weight of the person is 75 kg, the exposure level for Pb for this person from this drinking water source is _____ mg/kg/day (rounded off to 2 decimal places).</p>
Q.64	<p>In a region, total annual consumption of gasoline is 30.6 million tons. The land required for growing sugarcane to produce enough bioethanol to replace the gasoline completely is _____ <math>\text{km}^2</math> (an integer value).</p> <p>Ethanol energy equivalent is 67% of gasoline, gasoline density is <math>850 \text{ kg/m}^3</math>, yield of bioethanol produced from sugarcane per hectare of land is 3750 L, and <math>1 \text{ km}^2 = 100</math> hectares.</p>
Q.65	<p>Initially a bottle contained 400 g of ethanol. Half of ethanol was used by a student for preparing the stock solution in an environmental chemistry laboratory just before summer vacation of 90 days. After completing the procedure, the student left the bottle uncorked. If the unsealed bottle losses ethanol at a rate of 0.5 g/day, the ethanol that will be left in the bottle at the end of the summer vacation is _____ g (an integer value).</p>