



collegebatch.com

click to campus

GATE 2024 Electronics and Communication Engineering (EC) Question Paper

Graduate Aptitude Test in Engineering (GATE)

Download more GATE Previous Year Question Papers: [Click Here](#)

General Aptitude (GA)

Q.1 – Q.5 Carry ONE mark Each

Q.1 If '→' denotes increasing order of intensity, then the meaning of the words [charm → enamor → bewitch] is analogous to [bored → _____ → weary]. Which one of the given options is appropriate to fill the blank?

- (A) jaded
- (B) baffled
- (C) dead
- (D) worsted

GATE 2024

Q.2 P, Q, R, S, and T have launched a new startup. Two of them are siblings. The office of the startup has just three rooms. All of them agree that the siblings should not share the same room.

If S and Q are single children, and the room allocations shown below are acceptable to all,

P R	T S	Q
-----	-----	---

P Q	R T	S
-----	-----	---

then, which one of the given options is the siblings?

- (A) P and T
- (B) P and S
- (C) T and Q
- (D) T and R

Q.3 Five years ago, the ratio of Aman's age to his father's age was 1:4, and five years from now, the ratio will be 2:5. What was his father's age when Aman was born?

(A) 28 years

(B) 30 years

(C) 35 years

(D) 32 years

Q.4 For a real number $x > 1$,

$$\frac{1}{\log_2 x} + \frac{1}{\log_3 x} + \frac{1}{\log_4 x} = 1$$

The value of x is

(A) 4

(B) 12

(C) 24

(D) 36

Q.5 The greatest prime factor of $(3^{199} - 3^{196})$ is

(A) 13

(B) 17

(C) 3

(D) 11

GATE 2024

Q.6 – Q.10 Carry TWO marks Each

Q.6 Sequence the following sentences (P, Q, R, S) in a coherent passage:

P: Shifu's student exclaimed, "Why do you run since the bull is an illusion?"

Q: Shifu said, "Surely my running away from the bull is also an illusion."

R: Shifu once proclaimed that all life is illusion.

S: One day, when a bull gave him chase, Shifu began running for his life.

(A) SPRQ

(B) SRPQ

(C) RSPQ

(D) RPQS

- Q.7 Four identical cylindrical chalk-sticks, each of radius $r = 0.5$ cm and length $l = 10$ cm, are bound tightly together using a duct tape as shown in the following figure.

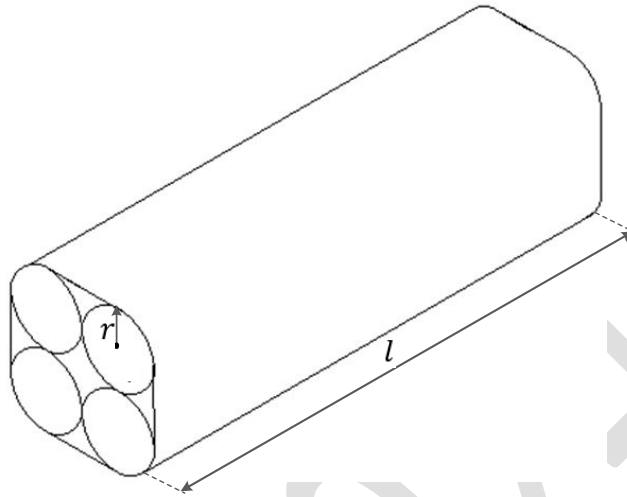

The width of the duct tape is equal to the length of the chalk-stick. The area (in cm^2) of the duct tape required to wrap the bundle of chalk-sticks once, is

- (A) $20(4 + \pi)$
(B) $20(8 + \pi)$
(C) $10(8 + \pi)$
(D) $10(4 + \pi)$

Q.8 The bar chart shows the data for the percentage of population falling into different categories based on Body Mass Index (BMI) in 2003 and 2023.

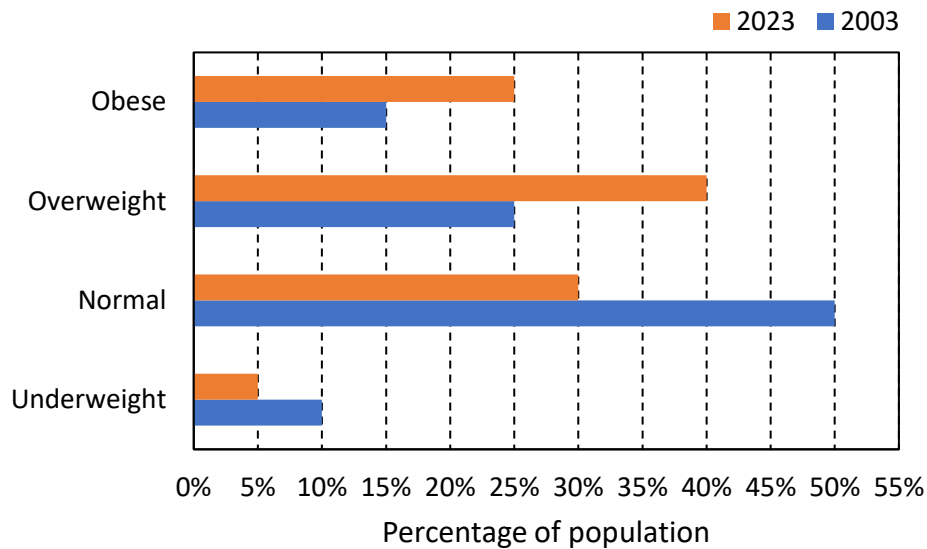

Based on the data provided, which one of the following options is INCORRECT?

- (A) The ratio of the percentage of population falling into overweight category to the percentage of population falling into normal category has increased in 20 years.
- (B) The ratio of the percentage of population falling into underweight category to the percentage of population falling into normal category has decreased in 20 years.
- (C) The ratio of the percentage of population falling into obese category to the percentage of population falling into normal category has decreased in 20 years.
- (D) The percentage of population falling into normal category has decreased in 20 years.

Q.9 Examples of mirror and water reflections are shown in the figures below:

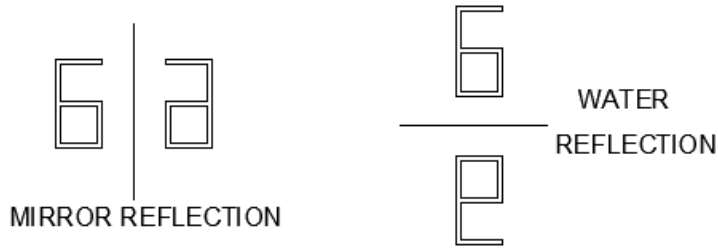

An object appears as the following image after first reflecting in a mirror and then reflecting on water.

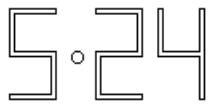

The original object is



Q.10 Two identical sheets A and B, of dimensions $24 \text{ cm} \times 16 \text{ cm}$, can be folded into half using two distinct operations, FO1 or FO2.

In FO1, the axis of folding remains parallel to the initial long edge, and in FO2, the axis of folding remains parallel to the initial short edge.

If sheet A is folded twice using FO1, and sheet B is folded twice using FO2, the ratio of the perimeters of the final shapes of A and B is

(A) 14:11

(B) 11:14

(C) 18:11

(D) 11:18

GATE 2024

Q.11 – Q.35 Carry ONE mark Each

Q.11 The general form of the complementary function of a differential equation is given by $y(t) = (At + B)e^{-2t}$, where A and B are real constants determined by the initial condition. The corresponding differential equation is _____.

(A) $\frac{d^2y}{dt^2} + 4\frac{dy}{dt} + 4y = f(t)$

(B) $\frac{d^2y}{dt^2} + 4y = f(t)$

(C) $\frac{d^2y}{dt^2} + 3\frac{dy}{dt} + 2y = f(t)$

(D) $\frac{d^2y}{dt^2} + 5\frac{dy}{dt} + 6y = f(t)$

Q.12 In the context of Bode magnitude plots, 40 dB/decade is the same as _____.

(A) 12 dB/octave

(B) 6 dB/octave

(C) 20 dB/octave

(D) 10 dB/octave

Q.13 In the feedback control system shown in the figure below $G(s) = \frac{6}{s(s+1)(s+2)}$.

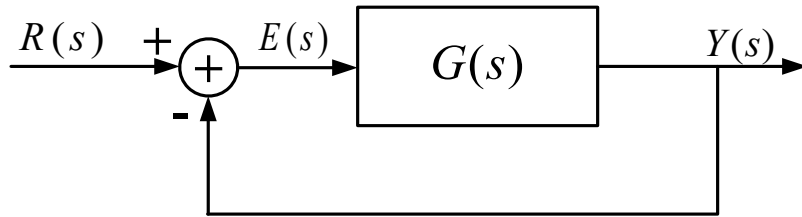

$R(s)$, $Y(s)$, and $E(s)$ are the Laplace transforms of $r(t)$, $y(t)$, and $e(t)$, respectively. If the input $r(t)$ is a unit step function, then _____.

- (A) $\lim_{t \rightarrow \infty} e(t) = 0$
- (B) $\lim_{t \rightarrow \infty} e(t) = \frac{1}{3}$
- (C) $\lim_{t \rightarrow \infty} e(t) = \frac{1}{4}$
- (D) $\lim_{t \rightarrow \infty} e(t)$ does not exist, $e(t)$ is oscillatory

- Q.14 A digital communication system transmits through a noiseless bandlimited channel $[-W W]$. The received signal $z(t)$ at the output of the receiving filter is given by $z(t) = \sum_n b[n]x(t - nT)$ where $b[n]$ are the symbols and $x(t)$ is the overall system response to a single symbol. The received signal is sampled at $t = mT$. The Fourier transform of $x(t)$ is $X(f)$. The Nyquist condition that $X(f)$ must satisfy for zero intersymbol interference at the receiver is _____.

(A)
$$\sum_{m=-\infty}^{\infty} X\left(f + \frac{m}{T}\right) = T$$

(B)
$$\sum_{m=-\infty}^{\infty} X\left(f + \frac{m}{T}\right) = \frac{1}{T}$$

(C)
$$\sum_{m=-\infty}^{\infty} X(f + mT) = T$$

(D)
$$\sum_{m=-\infty}^{\infty} X(f + mT) = \frac{1}{T}$$

Q.15 Consider a lossless transmission line terminated with a short circuit as shown in the figure below. As one moves towards the generator from the load, the normalized impedances z_{inA} , z_{inB} , z_{inC} , and z_{inD} (indicated in the figure) are _____.

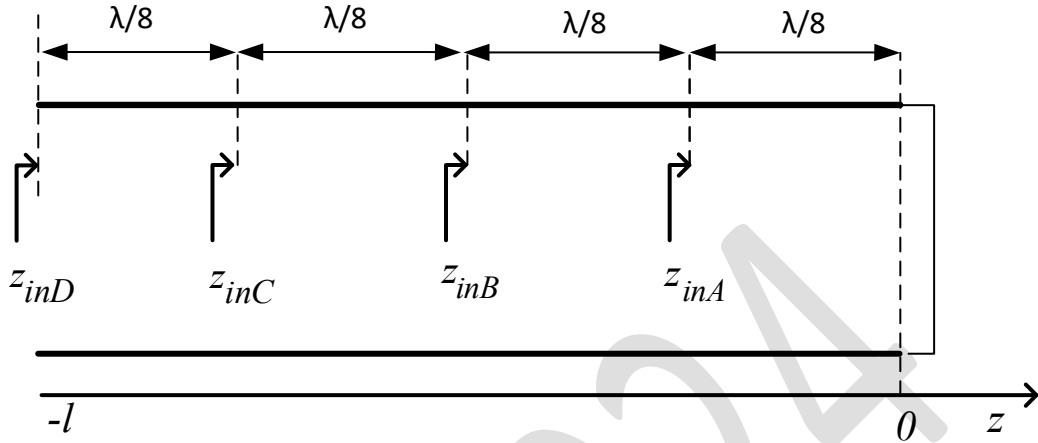

- (A) $z_{inA} = +1j \Omega$, $z_{inB} = \infty$, $z_{inC} = -1j \Omega$, $z_{inD} = 0$
- (B) $z_{inA} = \infty$, $z_{inB} = +0.4j \Omega$, $z_{inC} = 0$, $z_{inD} = +0.4j \Omega$
- (C) $z_{inA} = -1j \Omega$, $z_{inB} = 0$, $z_{inC} = +1j \Omega$, $z_{inD} = \infty$
- (D) $z_{inA} = +0.4j \Omega$, $z_{inB} = \infty$, $z_{inC} = -0.4j \Omega$, $z_{inD} = 0$

Q.16 Let \hat{i} and \hat{j} be the unit vectors along x and y axes, respectively and let A be a positive constant. Which one of the following statements is true for the vector fields $\vec{F}_1 = A(\hat{i}y + \hat{j}x)$ and $\vec{F}_2 = A(\hat{i}y - \hat{j}x)$?

- (A) Both \vec{F}_1 and \vec{F}_2 are electrostatic fields.
- (B) Only \vec{F}_1 is an electrostatic field.
- (C) Only \vec{F}_2 is an electrostatic field.
- (D) Neither \vec{F}_1 nor \vec{F}_2 is an electrostatic field.

- Q.17 In the circuit below, assume that the long channel NMOS transistor is biased in saturation. The small signal trans-conductance of the transistor is g_m . Neglect body effect, channel length modulation and intrinsic device capacitances. The small signal input impedance $Z_{in}(j\omega)$ is _____.

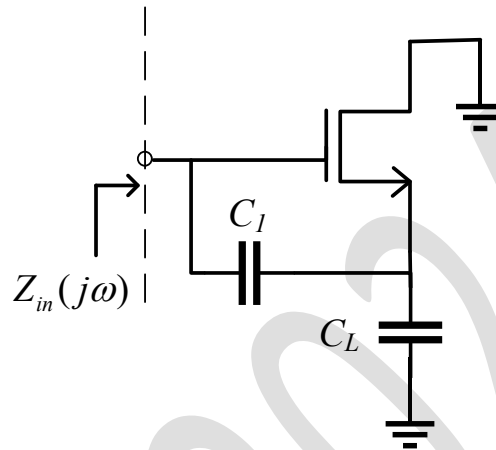

- (A) $\frac{-g_m}{C_1 C_L \omega^2} + \frac{1}{j\omega C_1} + \frac{1}{j\omega C_L}$
- (B) $\frac{g_m}{C_1 C_L \omega^2} + \frac{1}{j\omega C_1} + \frac{1}{j\omega C_L}$
- (C) $\frac{1}{j\omega C_1} + \frac{1}{j\omega C_L}$
- (D) $\frac{-g_m}{C_1 C_L \omega^2} + \frac{1}{j\omega C_1 + j\omega C_L}$

- Q.18 For the closed loop amplifier circuit shown below, the magnitude of open loop low frequency small signal voltage gain is 40. All the transistors are biased in saturation. The current source I_{SS} is ideal. Neglect body effect, channel length modulation and intrinsic device capacitances. The closed loop low frequency small signal voltage gain $\frac{v_{out}}{v_{in}}$ (rounded off to three decimal places) is ____.

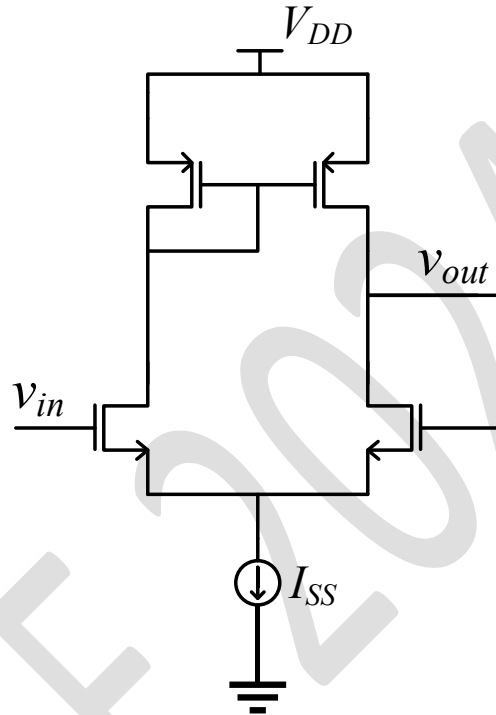

- (A) 0.976
 (B) 1.000
 (C) 1.025
 (D) 0.488

Q.19 For the Boolean function

$$F(A, B, C, D) = \sum m(0, 2, 5, 7, 8, 10, 12, 13, 14, 15),$$

the essential prime implicants are _____.

- (A) $BD, \bar{B}\bar{D}$
- (B) BD, AB
- (C) $AB, \bar{B}\bar{D}$
- (D) $BD, \bar{B}\bar{D}, AB$

Q.20 A white Gaussian noise $w(t)$ with zero mean and power spectral density $\frac{N_0}{2}$, when applied to a first-order RC low pass filter produces an output $n(t)$. At a particular time $t = t_k$, the variance of the random variable $n(t_k)$ is _____.

- (A) $\frac{N_0}{4RC}$
- (B) $\frac{N_0}{2RC}$
- (C) $\frac{N_0}{RC}$
- (D) $\frac{2N_0}{RC}$

Q.21 A causal and stable LTI system with impulse response $h(t)$ produces an output $y(t)$ for an input signal $x(t)$. A signal $x(0.5t)$ is applied to another causal and stable LTI system with impulse response $h(0.5t)$. The resulting output is _____.

- (A) $2y(0.5t)$
- (B) $4y(0.5t)$
- (C) $0.25y(2t)$
- (D) $0.25y(0.25t)$

GATE 2024

Q.22 For non-degenerately doped n-type silicon, which one of the following plots represents the temperature (T) dependence of free electron concentration (n)?

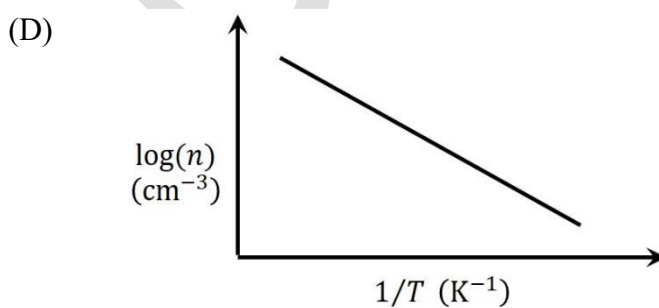
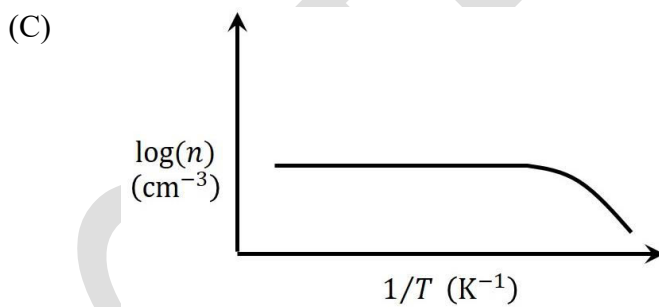
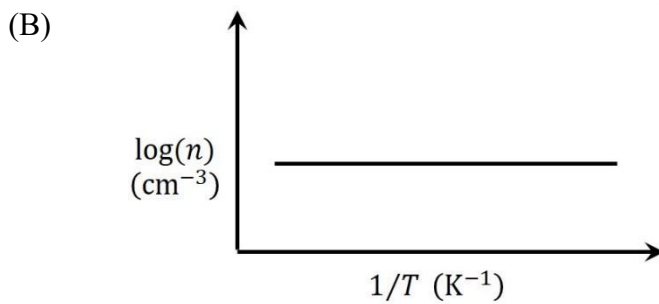
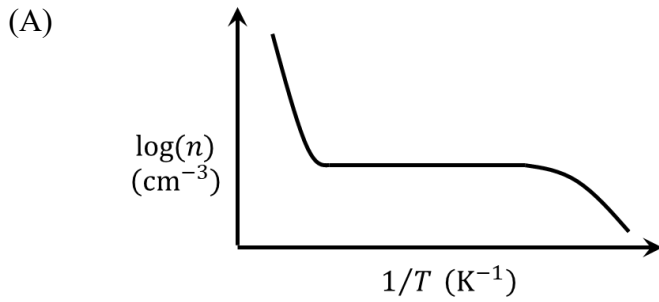

- Q.23 In the circuit shown, the $n:1$ step-down transformer and the diodes are ideal. The diodes have no voltage drop in forward biased condition. If the input voltage (in Volts) is $V_s(t) = 10\sin\omega t$ and the average value of load voltage $V_L(t)$ (in Volts) is $2.5/\pi$, the value of n is _____.

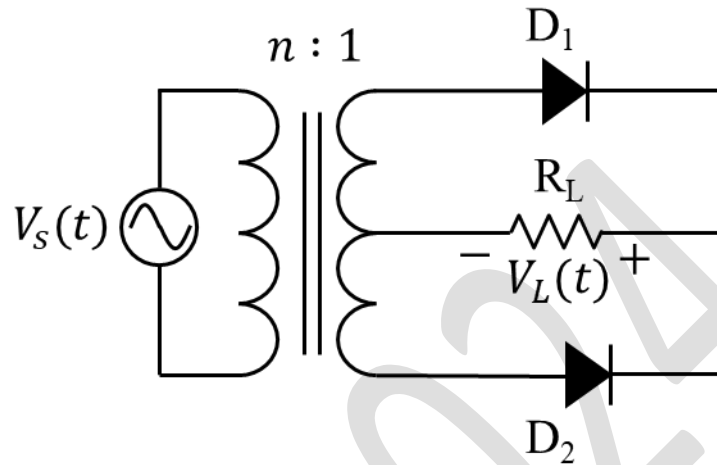

- (A) 4
(B) 8
(C) 12
(D) 16

Q.24 For a causal discrete-time LTI system with transfer function

$$H(z) = \frac{2z^2 + 3}{\left(z + \frac{1}{3}\right)\left(z - \frac{1}{3}\right)}$$

which of the following statements is/are true?

- (A) The system is stable.
- (B) The system is a minimum phase system.
- (C) The initial value of the impulse response is 2.
- (D) The final value of the impulse response is 0.

Q.25 Let $\rho(x, y, z, t)$ and $u(x, y, z, t)$ represent density and velocity, respectively, at a point (x, y, z) and time t . Assume $\frac{\partial \rho}{\partial t}$ is continuous. Let V be an arbitrary volume in space enclosed by the closed surface S and \hat{n} be the outward unit normal of S . Which of the following equations is/are equivalent to $\frac{\partial \rho}{\partial t} + \nabla \cdot (\rho u) = 0$?

(A)
$$\int_V \frac{\partial \rho}{\partial t} dv = - \oint_S \rho u \cdot \hat{n} ds$$

(B)
$$\int_V \frac{\partial \rho}{\partial t} dv = \oint_S \rho u \cdot \hat{n} ds$$

(C)
$$\int_V \frac{\partial \rho}{\partial t} dv = - \int_V \nabla \cdot (\rho u) dv$$

(D)
$$\int_V \frac{\partial \rho}{\partial t} dv = \int_V \nabla \cdot (\rho u) dv$$

- Q.26 The free electron concentration profile $n(x)$ in a doped semiconductor at equilibrium is shown in the figure, where the points A, B, and C mark three different positions. Which of the following statements is/are true?

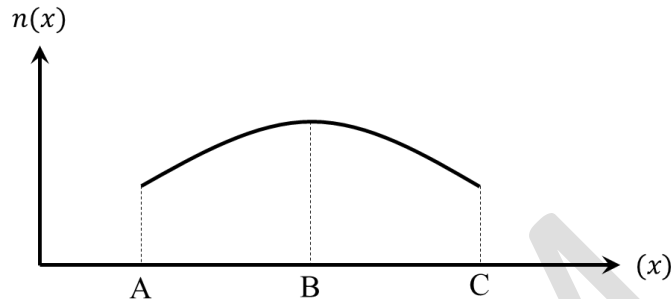

- (A) For x between B and C, the electron diffusion current is directed from C to B.
- (B) For x between B and A, the electron drift current is directed from B to A.
- (C) For x between B and C, the electric field is directed from B to C.
- (D) For x between B and A, the electric field is directed from A to B.

- Q.27 A machine has a 32-bit architecture with 1-word long instructions. It has 24 registers and supports an instruction set of size 40. Each instruction has five distinct fields, namely opcode, two source register identifiers, one destination register identifier, and an immediate value. Assuming that the immediate operand is an unsigned integer, its maximum value is _____.

Q.28 An amplitude modulator has output (in Volts)

$$s(t) = A \cos(400\pi t) + B \cos(360\pi t) + B \cos(440\pi t).$$

The carrier power normalized to 1Ω resistance is 50 Watts. The ratio of the total sideband power to the total power is $1/9$. The value of B (in Volts, rounded off to two decimal places) is _____.

Q.29 In a number system of base r , the equation $x^2 - 12x + 37 = 0$ has $x = 8$ as one of its solutions. The value of r is _____.

Q.30 Let \mathbb{R} and \mathbb{R}^3 denote the set of real numbers and the three dimensional vector space over it, respectively. The value of α for which the set of vectors

$$\{[2 \quad -3 \quad \alpha], [3 \quad -1 \quad 3], [1 \quad -5 \quad 7]\}$$

does not form a basis of \mathbb{R}^3 is _____.

Q.31 In the given circuit, the current I_x (in mA) is _____.

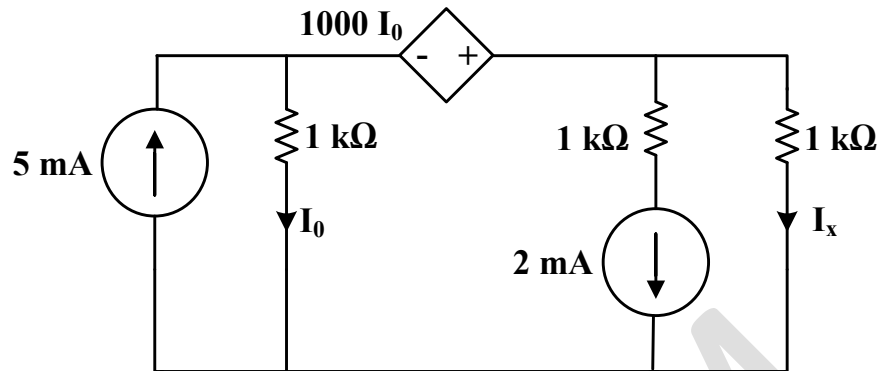

Q.32 In the circuit given below, the switch S was kept open for a sufficiently long time and is closed at time $t = 0$. The time constant (in seconds) of the circuit for $t > 0$ is _____.

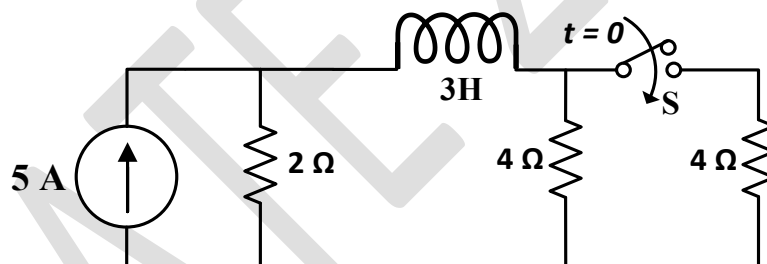

Q.33 Suppose X and Y are independent and identically distributed random variables that are distributed uniformly in the interval $[0,1]$. The probability that $X \geq Y$ is _____.

Q.34 A source transmits symbols from an alphabet of size 16. The value of maximum achievable entropy (in bits) is _____ .

Q.35 As shown in the circuit, the initial voltage across the capacitor is 10 V, with the switch being open. The switch is then closed at $t = 0$. The total energy dissipated in the ideal Zener diode ($V_Z = 5\text{ V}$) after the switch is closed (in mJ, rounded off to three decimal places) is _____ .

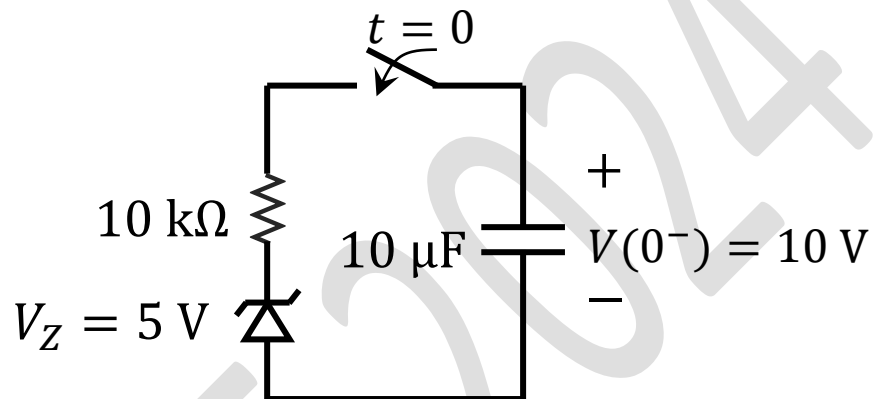

Q.36 – Q.65 Carry TWO marks Each

Q.36 Consider the Earth to be a perfect sphere of radius R . Then the surface area of the region, enclosed by the 60°N latitude circle, that contains the north pole in its interior is _____.

(A) $(2 - \sqrt{3})\pi R^2$

(B) $\frac{(\sqrt{2} - 1)\pi R^2}{2}$

(C) $\frac{2\pi R^2}{3}$

(D) $\frac{(2 + \sqrt{3})\pi R^2}{8\sqrt{2}}$

GATE 2024

- Q.37 Consider a unity negative feedback control system with forward path gain $G(s) = \frac{K}{(s+1)(s+2)(s+3)}$ as shown.

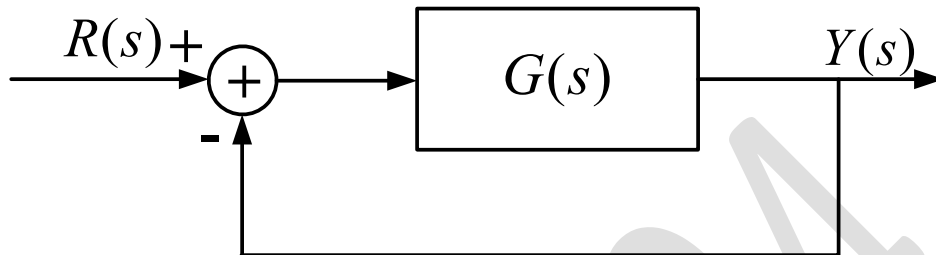

The impulse response of the closed-loop system decays faster than e^{-t} if _____.

- (A) $1 \leq K \leq 5$
- (B) $7 \leq K \leq 21$
- (C) $-4 \leq K \leq -1$
- (D) $-24 \leq K \leq -6$

- Q.38 A satellite attitude control system, as shown below, has a plant with transfer function $G(s) = \frac{1}{s^2}$ cascaded with a compensator $C(s) = \frac{K(s+\alpha)}{s+4}$, where K and α are positive real constants.

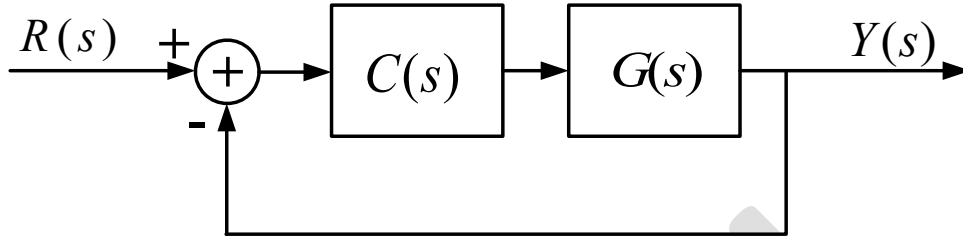

In order for the closed-loop system to have poles at $-1 \pm j\sqrt{3}$, the value of α must be _____.

- (A) 0
(B) 1
(C) 2
(D) 3

Q.39 A uniform plane wave with electric field $\vec{E}(x) = A_y \hat{a}_y e^{-j\frac{2\pi x}{3}}$ V/m is travelling in the air (relative permittivity, $\epsilon_r = 1$ and relative permeability, $\mu_r = 1$) in the $+x$ direction (A_y is a positive constant, \hat{a}_y is the unit vector along the y axis). It is incident normally on an ideal electric conductor (conductivity, $\sigma = \infty$) at $x = 0$. The position of the first null of the total magnetic field in the air (measured from $x = 0$, in metres) is _____.

(A) $-\frac{3}{4}$

(B) $-\frac{3}{2}$

(C) -6

(D) -3

Q.40 A 4-bit priority encoder has inputs D_3, D_2, D_1 , and D_0 in descending order of priority. The two-bit output AB is generated as 00, 01, 10, and 11 corresponding to inputs D_3, D_2, D_1 , and D_0 , respectively. The Boolean expression of the output bit B is _____.

(A) $\overline{D_3} \overline{D_2}$

(B) $\overline{D_3} D_2 + \overline{D_3} \overline{D_1}$

(C) $D_3 \overline{D_2} + \overline{D_3} D_1$

(D) $\overline{D_3} \overline{D_1}$

- Q.41 The propagation delay of the 2×1 MUX shown in the circuit is 10 ns. Consider the propagation delay of the inverter as 0 ns.

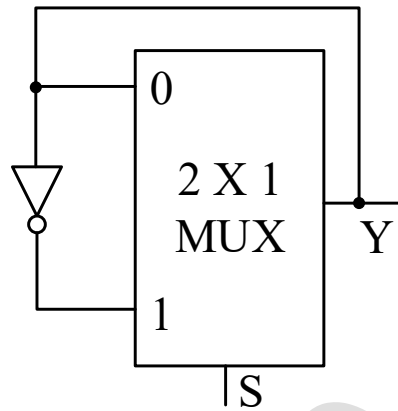

If S is set to 1 then the output Y is _____.

- (A) a square wave of frequency 100 MHz
- (B) a square wave of frequency 50 MHz
- (C) constant at 0
- (D) constant at 1

Q.42 The sequence of states (Q_1Q_0) of the given synchronous sequential circuit is _____.

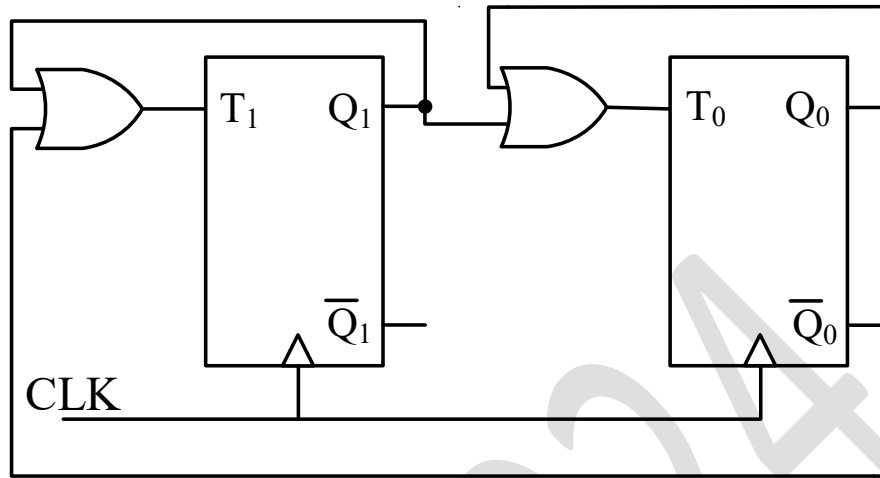

- (A) $00 \rightarrow 10 \rightarrow 11 \rightarrow 00$
- (B) $11 \rightarrow 00 \rightarrow 10 \rightarrow 01 \rightarrow 00$
- (C) $01 \rightarrow 10 \rightarrow 11 \rightarrow 00 \rightarrow 01$
- (D) $00 \rightarrow 01 \rightarrow 10 \rightarrow 00$

Q.43 Let z be a complex variable. If $f(z) = \frac{\sin(\pi z)}{z^2(z-2)}$ and C is the circle in the complex plane with $|z| = 3$ then $\oint_C f(z) dz$ is _____.

(A) $\pi^2 j$

(B) $j\pi\left(\frac{1}{2} - \pi\right)$

(C) $j\pi\left(\frac{1}{2} + \pi\right)$

(D) $-\pi^2 j$

GATE 2024

Q.44 Consider two continuous time signals $x(t)$ and $y(t)$ as shown below

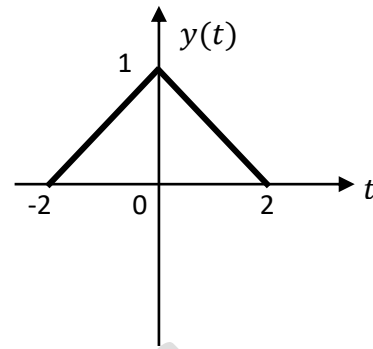
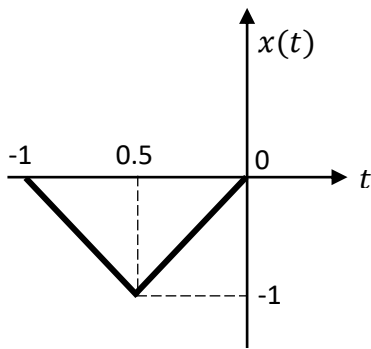

If $X(f)$ denotes the Fourier transform of $x(t)$, then the Fourier transform of $y(t)$ is _____.

- (A) $-4X(4f)e^{-j\pi f}$
- (B) $-4X(4f)e^{-j4\pi f}$
- (C) $-\frac{1}{4}X(f/4)e^{-j\pi f}$
- (D) $-\frac{1}{4}X(f/4)e^{-j4\pi f}$

Q.45 A source transmits a symbol s , taken from $\{-4, 0, 4\}$ with equal probability, over an additive white Gaussian noise channel. The received noisy symbol r is given by $r = s + w$, where the noise w is zero mean with variance 4 and is independent of s .

Using $Q(x) = \frac{1}{\sqrt{2\pi}} \int_x^\infty e^{-\frac{t^2}{2}} dt$, the optimum symbol error probability is _____.

(A) $\frac{2}{3}Q(2)$

(B) $\frac{4}{3}Q(1)$

(C) $\frac{2}{3}Q(1)$

(D) $\frac{4}{3}Q(2)$

Q.46 A full scale sinusoidal signal is applied to a 10-bit ADC. The fundamental signal component in the ADC output has a normalized power of 1 W, and the total noise and distortion normalized power is 10 μ W. The effective number of bits (*rounded off to the nearest integer*) of the ADC is _____.

(A) 7

(B) 8

(C) 9

(D) 10

Q.47 The information bit sequence $\{1\ 1\ 1\ 0\ 1\ 0\ 1\ 0\ 1\}$ is to be transmitted by encoding with Cyclic Redundancy Check 4 (CRC-4) code, for which the generator polynomial is $C(x) = x^4 + x + 1$. The encoded sequence of bits is _____.

- (A) $\{1\ 1\ 1\ 0\ 1\ 0\ 1\ 0\ 1\ 1\ 1\ 0\ 0\}$
- (B) $\{1\ 1\ 1\ 0\ 1\ 0\ 1\ 0\ 1\ 1\ 1\ 0\ 1\}$
- (C) $\{1\ 1\ 1\ 0\ 1\ 0\ 1\ 0\ 1\ 1\ 1\ 1\ 0\}$
- (D) $\{1\ 1\ 1\ 0\ 1\ 0\ 1\ 0\ 1\ 0\ 1\ 0\ 0\}$

Q.48 A continuous time signal $x(t) = 2 \cos(8\pi t + \pi/3)$ is sampled at a rate of 15 Hz. The sampled signal $x_s(t)$ when passed through an LTI system with impulse response

$$h(t) = \left(\frac{\sin 2\pi t}{\pi t}\right) \cos(38\pi t - \pi/2)$$

produces an output $x_o(t)$. The expression for $x_o(t)$ is _____.

- (A) $15 \sin(38\pi t + \pi/3)$
- (B) $15 \sin(38\pi t - \pi/3)$
- (C) $15 \cos(38\pi t - \pi/6)$
- (D) $15 \cos(38\pi t + \pi/6)$

Q.49 The opamps in the circuit shown are ideal, but have saturation voltages of ± 10 V.

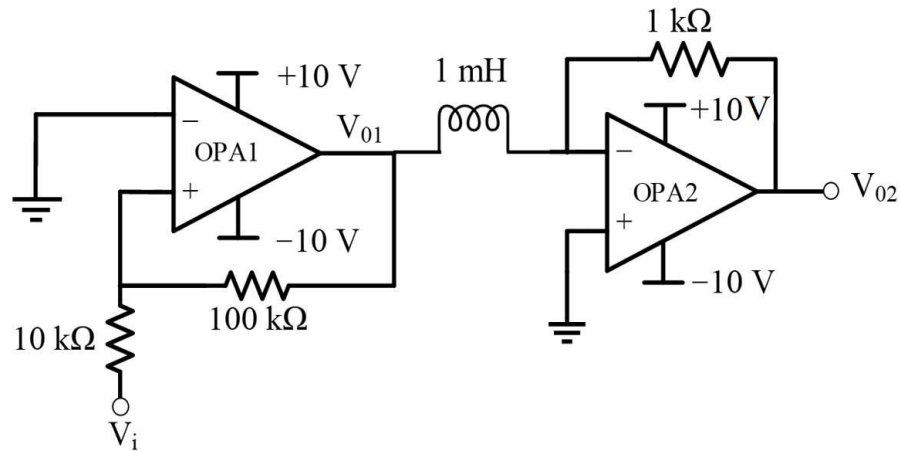

Assume that the initial inductor current is 0 A. The input voltage (V_i) is a triangular signal with peak voltages of ± 2 V and time period of $8 \mu\text{s}$. Which one of the following statements is true?

- (A) V_{01} is delayed by $2 \mu\text{s}$ relative to V_i , and V_{02} is a triangular waveform.
- (B) V_{01} is not delayed relative to V_i , and V_{02} is a trapezoidal waveform.
- (C) V_{01} is not delayed relative to V_i , and V_{02} is a triangular waveform.
- (D) V_{01} is delayed by $1 \mu\text{s}$ relative to V_i , and V_{02} is a trapezoidal waveform.

Q.50 In the circuit below, the opamp is ideal.

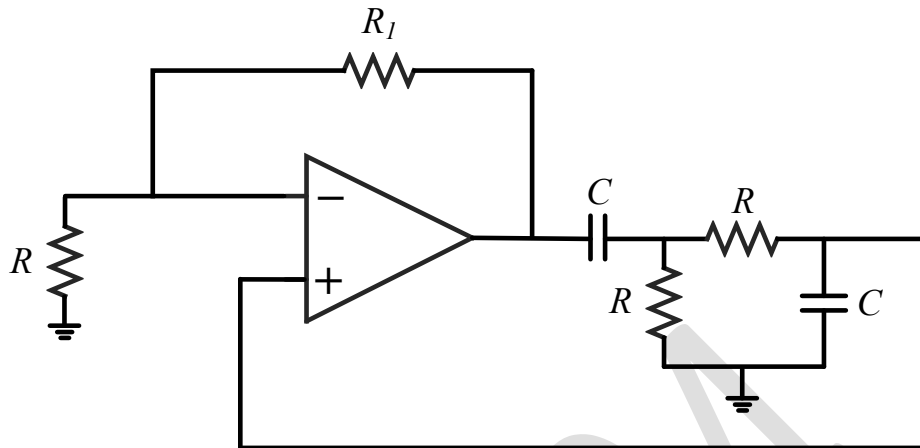

If the circuit is to show sustained oscillations, the respective values of R_1 and the corresponding frequency of oscillation are _____.

- (A) $29R$ and $1/(2\pi\sqrt{6}RC)$
- (B) $2R$ and $1/(2\pi RC)$
- (C) $29R$ and $1/(2\pi RC)$
- (D) $2R$ and $1/(2\pi\sqrt{6}RC)$

Q.51 In the circuit shown below, the transistors M_1 and M_2 are biased in saturation. Their small signal transconductances are g_{m1} and g_{m2} respectively. Neglect body effect, channel length modulation and intrinsic device capacitances.

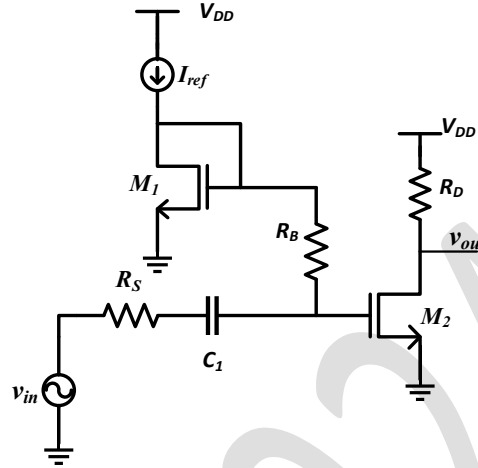

Assuming that capacitor C_1 is a short circuit for AC analysis, the exact magnitude of small signal voltage gain $\left| \frac{v_{out}}{v_{in}} \right|$ is _____.

(A) $g_{m2}R_D$

(B)
$$\frac{g_{m2}R_D \left(R_B + \frac{1}{g_{m1}} \right)}{R_B + \frac{1}{g_{m1}} + R_S}$$

(C)
$$\frac{g_{m2}R_D \left(R_B + \frac{1}{g_{m1}} + R_S \right)}{R_B + \frac{1}{g_{m1}}}$$

(D)
$$\frac{g_{m2}R_D \left(\frac{1}{g_{m1}} \right)}{\frac{1}{g_{m1}} + R_S}$$

- Q.52 Which of the following statements is/are true for a BJT with respect to its DC current gain β ?
- (A) Under high-level injection condition in forward active mode, β will decrease with increase in the magnitude of collector current.
 - (B) Under low-level injection condition in forward active mode, where the current at the emitter-base junction is dominated by recombination-generation process, β will decrease with increase in the magnitude of collector current.
 - (C) β will be lower when the BJT is in saturation region compared to when it is in active region.
 - (D) A higher value of β will lead to a lower value of the collector-to-emitter breakdown voltage.

Q.53 Consider a system S represented in state space as

$$\frac{dx}{dt} = \begin{bmatrix} 0 & -2 \\ 1 & -3 \end{bmatrix} x + \begin{bmatrix} 1 \\ 0 \end{bmatrix} r, \quad y = [2 \quad -5]x.$$

Which of the state space representations given below has/have the same transfer function as that of S ?

(A) $\frac{dx}{dt} = \begin{bmatrix} 0 & 1 \\ -2 & -3 \end{bmatrix} x + \begin{bmatrix} 0 \\ 1 \end{bmatrix} r, \quad y = [1 \quad 2]x$

(B) $\frac{dx}{dt} = \begin{bmatrix} 0 & 1 \\ -2 & -3 \end{bmatrix} x + \begin{bmatrix} 1 \\ 0 \end{bmatrix} r, \quad y = [0 \quad 2]x$

(C) $\frac{dx}{dt} = \begin{bmatrix} -1 & 0 \\ 0 & -2 \end{bmatrix} x + \begin{bmatrix} -1 \\ 3 \end{bmatrix} r, \quad y = [1 \quad 1]x$

(D) $\frac{dx}{dt} = \begin{bmatrix} -1 & 0 \\ 0 & -2 \end{bmatrix} x + \begin{bmatrix} 1 \\ 1 \end{bmatrix} r, \quad y = [1 \quad 2]x$

Q.54 Let $F_1, F_2,$ and F_3 be functions of (x, y, z) . Suppose that for every given pair of points A and B in space, the line integral $\int_C (F_1 dx + F_2 dy + F_3 dz)$ evaluates to the same value along any path C that starts at A and ends at B . Then which of the following is/are true?

(A) For every closed path Γ , we have $\oint_{\Gamma} (F_1 dx + F_2 dy + F_3 dz) = 0$.

(B) There exists a differentiable scalar function $f(x, y, z)$ such that $F_1 = \frac{\partial f}{\partial x}, F_2 = \frac{\partial f}{\partial y}, F_3 = \frac{\partial f}{\partial z}$.

(C) $\frac{\partial F_1}{\partial x} + \frac{\partial F_2}{\partial y} + \frac{\partial F_3}{\partial z} = 0$.

(D) $\frac{\partial F_3}{\partial y} = \frac{\partial F_2}{\partial z}, \frac{\partial F_1}{\partial z} = \frac{\partial F_3}{\partial x}, \frac{\partial F_2}{\partial x} = \frac{\partial F_1}{\partial y}$.

Q.55 Consider the matrix $\begin{bmatrix} 1 & k \\ 2 & 1 \end{bmatrix}$, where k is a positive real number. Which of the following vectors is/are eigenvector(s) of this matrix?

(A) $\begin{bmatrix} 1 \\ -\sqrt{2/k} \end{bmatrix}$

(B) $\begin{bmatrix} 1 \\ \sqrt{2/k} \end{bmatrix}$

(C) $\begin{bmatrix} \sqrt{2k} \\ 1 \end{bmatrix}$

(D) $\begin{bmatrix} \sqrt{2k} \\ -1 \end{bmatrix}$

Q.56 The radian frequency value(s) for which the discrete time sinusoidal signal $x[n] = A \cos(\Omega n + \pi/3)$ has a period of 40 is/are _____.

(A) 0.15π

(B) 0.225π

(C) 0.3π

(D) 0.45π

Q.57 Let $X(t) = A \cos(2\pi f_0 t + \theta)$ be a random process, where amplitude A and phase θ are independent of each other, and are uniformly distributed in the intervals $[-2, 2]$ and $[0, 2\pi]$, respectively. $X(t)$ is fed to an 8-bit uniform mid-rise type quantizer. Given that the autocorrelation of $X(t)$ is $R_X(\tau) = \frac{2}{3} \cos(2\pi f_0 \tau)$, the signal to quantization noise ratio (in dB, rounded off to two decimal places) at the output of the quantizer is _____.

Q.58 A lossless transmission line with characteristic impedance $Z_0 = 50 \Omega$ is terminated with an unknown load. The magnitude of the reflection co-efficient is $|\Gamma| = 0.6$. As one moves towards the generator from the load, the maximum value of the input impedance magnitude looking towards the load (in Ω) is _____.

Q.59 The relationship between any N-length sequence $x[n]$ and its corresponding N-point discrete Fourier transform $X[k]$ is defined as

$$X[k] = \mathcal{F}\{x[n]\}.$$

Another sequence $y[n]$ is formed as below

$$y[n] = \mathcal{F}\left\{\mathcal{F}\left\{\mathcal{F}\left\{\mathcal{F}\{x[n]\}\right\}\right\}\right\}.$$

For the sequence $x[n] = \{1, 2, 1, 3\}$, the value of $Y[0]$ is _____.

Q.60 For the two port network shown below, the value of the Y_{21} parameter (in Siemens) is _____.

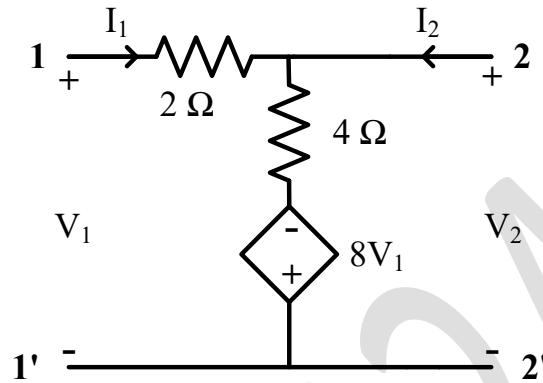

Q.61 Consider a MOS capacitor made with p-type silicon. It has an oxide thickness of 100 nm, a fixed positive oxide charge of 10^{-8} C/cm² at the oxide-silicon interface, and a metal work function of 4.6 eV. Assume that the relative permittivity of the oxide is 4 and the absolute permittivity of free space is 8.85×10^{-14} F/cm. If the flatband voltage is 0 V, the work function of the p-type silicon (in eV, rounded off to two decimal places) is _____.

Q.62 In the network shown below, maximum power is to be transferred to the load R_L .

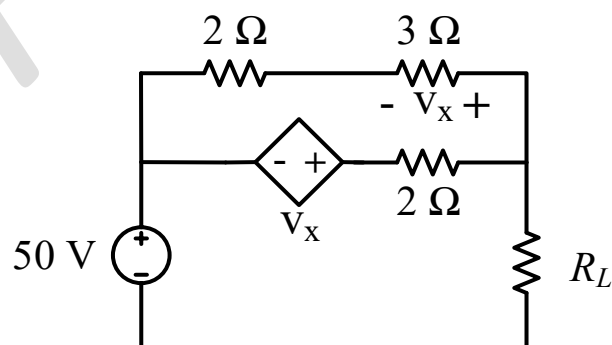

The value of R_L (in Ω) is _____.

- Q.63 A non-degenerate n-type semiconductor has 5% neutral dopant atoms. Its Fermi level is located at 0.25 eV below the conduction band (E_C) and the donor energy level (E_D) has a degeneracy of 2. Assuming the thermal voltage to be 20 mV, the difference between E_C and E_D (in eV, rounded off to two decimal places) is _____.
- Q.64 An NMOS transistor operating in the linear region has I_{DS} of 5 μA at V_{DS} of 0.1 V. Keeping V_{GS} constant, the V_{DS} is increased to 1.5 V.
Given that $\mu_n C_{ox} \frac{W}{L} = 50 \mu\text{A}/\text{V}^2$, the transconductance at the new operating point (in $\mu\text{A}/\text{V}$, rounded off to two decimal places) is _____.
- Q.65 The photocurrent of a PN junction diode solar cell is 1 mA. The voltage corresponding to its maximum power point is 0.3 V. If the thermal voltage is 30 mV, the reverse saturation current of the diode (in nA, rounded off to two decimal places) is _____.