



collegebatch.com

click to campus

COMEDK 2022 Question Paper with Solution

Consortium of Medical, Engineering and Dental Colleges of Karnataka
Under Graduate Entrance Test

Download more COMEDK Previous Year Question Papers: [Click Here](#)

Question 1

During the phenomenon of resonance

Options:

- A. the amplitude of oscillation becomes large
- B. the frequency of oscillation becomes large
- C. the time period of oscillation becomes large
- D. All of the above

Answer: A

Solution:

Solution:

During the phenomenon of resonance, the amplitude of oscillation becomes large.

Question 2

If the earth were to spin faster, acceleration due to gravity at the poles

Options:

- A. increases
- B. decreases
- C. remains the same
- D. depends on how fast it spins

Answer: C

Solution:

Solution:

The variation of g with angular velocity ω is given by

$$g' = g - R\omega^2$$

If earth were to spin faster, that is angular velocity increases, then except at poles, the weight of bodies will decrease at all places.

Question 3

Maximum amplitude of message signal in amplitude modulation is 20 cm. If the amplitude of carrier wave is 40 cm, then modulation index of modulated wave is

Options:

- A. 1
- B. 0.5
- C. 0.25
- D. 2

Answer: B

Solution:

Solution:

Given,

$$A_m = 20\text{cm}$$

$$A_c = 40\text{cm}$$

∴ Modulation index,

$$\mu = \frac{A_m}{A_c} = \frac{20}{40} = 0.5$$

Question 4

If heat engine is filled at temperature 27°C and heat of 100kcal is taken from source at temperature 677°C. Work done (in J) is

Options:

- A. 0.28×10^6
- B. 2.8×10^6
- C. 28×10^6
- D. 0.028×10^6

Answer: A

Solution:

Solution:

Given,

$$T_2 = 27^\circ\text{C} = 300\text{K}$$

$$T_1 = 677^\circ\text{C} = 950\text{K}$$

$$\eta = \frac{W}{Q_1} = \frac{Q_1 - Q_2}{Q_1}$$

$$= 1 - \frac{Q_2}{Q_1} = 1 - \frac{T_2}{T_1}$$

$$\therefore \eta = 1 - \frac{300}{950} = \frac{13}{19}$$

$$\therefore \eta W = \eta Q_1 = 100 \times 10^3 \times \frac{13}{19} \text{cal}$$

$$\text{Also, } 4.2\text{J} = 1\text{cal}$$

$$\therefore W = 100 \times 10^3 \times \frac{13}{19} \times 4.2$$

$$\Rightarrow W = 2.87 \times 10^5 = 0.28 \times 10^6\text{J}$$

Question 5

During α -decay, atomic mass of parent nuclei is

Options:

A. decreased by 2 units

B. increased by 2 units

C. decreased by 4 units

D. increased by 4 units

Answer: C

Solution:

Solution:

During alpha-decay, atomic mass of parent nuclei is decreased by 4 units while atomic number is decreased by 2 units.

Question 6

A point object is placed on the optic axis of a convex lens of focal length f at a distance of $2f$ to the left of it. The diameter of the lens is d . An eye is placed at a distance of $3f$ to the right of the lens and a distance h below the optic axis. The maximum value of h to see the image is

Options:

A. d

B. $\frac{d}{2}$

C. $\frac{d}{3}$

D. $\frac{d}{4}$

Answer: D

Solution:

Solution:

From two similar triangles,

$$\frac{h}{\frac{d}{2}} = \frac{f}{2f}$$

$$h = \frac{d}{4}$$

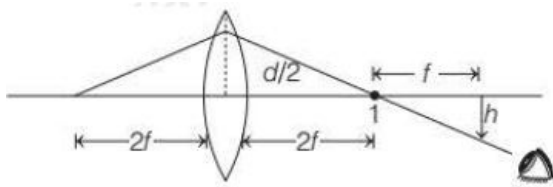

Question 7

For CE transistor amplifier, the audio signal voltage across the collector resistance of $4\text{k}\Omega$ is 5V . If the current amplification factor of the transistor is 100 and base resistance is $2\text{k}\Omega$, then input signal voltage is

Options:

- A. 75 mV
- B. 25 mV
- C. 20 mV
- D. 50 mV

Answer: B

Solution:

Solution:

Given, collector resistance = $R_{\text{out}} = 4\text{k}\Omega$

$\beta = 100$

$R_{\text{in}} = 2\text{k}\Omega$

$V_{\text{out}} = 5\text{V}$

\therefore Voltage amplification,

$$A_v = \beta \frac{R_{\text{out}}}{R_{\text{in}}} = \frac{V_{\text{out}}}{V_{\text{in}}}$$

$$V_{\text{in}} = \frac{V_{\text{out}} \times R_{\text{in}}}{\beta \times R_{\text{out}}}$$

$$= \frac{5 \times 2 \times 10^3}{100 \times 4 \times 10^3}$$

$$= \frac{1}{40} = 25\text{mV}$$

Question 8

From the following $p - V$ diagram, an ideal gas undergoing a change of state from A to B. Four different processes I, II, III and IV as shown in the figure may lead to same change of stat

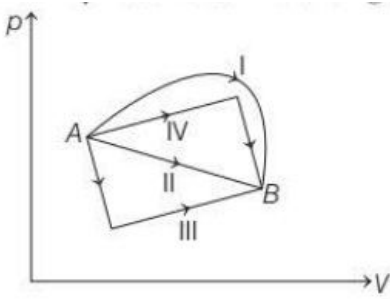

Options:

- A. Work done is maximum in case I
- B. Change in internal energy is same in all the four cases
- C. Change in internal energy is same in IV and III cases, but not in I and II
- D. Work done is minimum in case II

Answer: 0

Solution:

Solution:

(a, b) As work done = area under $p - V$ curve, work done is maximum in case I. Change in internal energy is independent of the path from A to B. Therefore, in all cases change in internal energy is same.

Question 9

A copper and a steel wire of same diameter are connected end to end. A deforming force F_1 is applied to the wire which causes an elongation of 1 cm. The two wires will have

Options:

- A. the same stress
- B. different stress
- C. the same strain
- D. different strain

Answer: 0

Solution:

Solution:

(a, d) As Young's modulus Y for two wires is different, hence strain is different but stress is same as equal force F on each wire having same diameter and area of cross-section act on both wires.

Question 10

If kinetic energy of a body is increased by 300%, then percentage change in momentum will be

Options:

- A. 100%
- B. 150%
- C. 265%
- D. 73.2%

Answer: A

Solution:

Solution:

$$\text{As, } K = \frac{1}{2}mv^2$$

$$\Rightarrow K = \frac{1}{2}mp^2$$

$$\Rightarrow p^2 = \frac{2mK}{m}$$

$$\Rightarrow p = \sqrt{2mK}$$

Suppose, p_1 is the momentum of the body and $K_1 =$ kinetic energy of the body initially. As the kinetic energy of the body is increased by 300%, new kinetic energy of the body $= K_1 + 3K_1$

Hence, percentage change in momentum

$$\begin{aligned} &= \frac{p_2 - p_1}{p_1} \times 100 \\ &= \frac{\sqrt{2mK_2} - \sqrt{2mK_1}}{\sqrt{2mK_1}} \times 100 \\ &= \frac{\sqrt{2m}\sqrt{K_2} - \sqrt{2m}\sqrt{K_1}}{\sqrt{2m}\sqrt{K_1}} \times 100 \\ &= \frac{\sqrt{K_1 + 3K_1} - \sqrt{K_1}}{\sqrt{K_1}} \times 100 \\ &= \frac{\sqrt{4K_1} - \sqrt{K_1}}{\sqrt{K_1}} \times 100 = 100\% \end{aligned}$$

Question 11

Which of the following diagram represents the variation of the electric field with distance r from the centre of a uniformly charged non-conducting sphere of radius R ?

Options:

A.

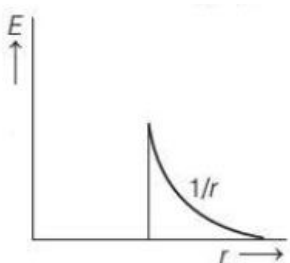

B.

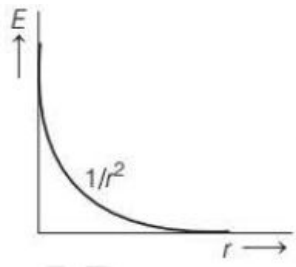

C.

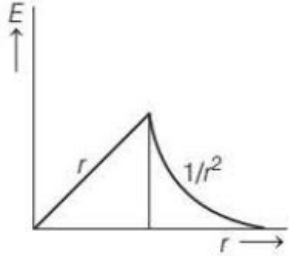

D.

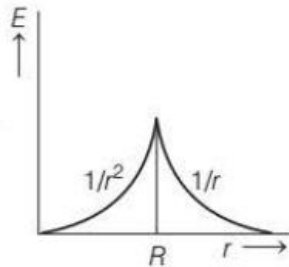

Answer: C

Solution:

Solution:

The electric field intensity at a point lying outside the sphere (non-conducting) is

$$E = \frac{1}{4\pi\epsilon_0} \cdot \frac{q}{r^2}$$

$$\Rightarrow E \propto \frac{1}{r^2} \dots\dots\dots (i)$$

The electric field intensity at the sphere ($r=R$),

$$E = \frac{1}{4\pi\epsilon_0 R^2} \cdot \frac{q}{R^2}$$

$$\Rightarrow E = \propto \frac{1}{R^2}$$

where, R being the radius of sphere.

The electric field intensity inside the sphere is

$$E = \frac{1}{4\pi\epsilon_0} \cdot \frac{q}{R^3}$$

$$\Rightarrow E \propto r$$

At the centre of sphere, $E = 0$

Hence, option (c) is correct representation.

Question 12

A DC ammeter and a hot wire ammeter are connected to a circuit in series. When a direct current is passed through circuit, the DC ammeter shows 6A. When AC current flows through circuit, what is the average readings in DC ammeter and the AC ammeter, if DC and AC currents

flow simultaneously through the circuit?

Options:

- A. DC = 6A, AC = 10A
- B. DC = 3A, AC = 5A
- C. DC = 5A, AC = 8A
- D. DC = 2A, AC = 3A

Answer: A

Solution:

Solution:

Resultant current is superposition of two currents,
i.e. I (instantaneous total current)

$$= 6 + I_0 \sin \omega t$$

DC ammeter will read average value

$$= 6 + I_0 \sin \omega t$$

$$= 6A (\because I_0 \sin \omega t = 0)$$

AC ammeter will read average value

$$= \sqrt{(6 + I_0 \sin^2 \omega t)^2}$$

$$= \sqrt{36 + 12I_0 \sin \omega t + I_0^2 \sin^2 \omega t} (\because I_0 \sin \omega t = 0)$$

$$\text{Since, } \sin^2 \omega t = \frac{1}{2} \text{ and } I_{\text{rms}} = 8 = \frac{I_0}{\sqrt{2}}$$

$$\therefore \text{AC reading} = \sqrt{36 + \frac{I_0^2}{2}} = \sqrt{36 + 64}$$
$$= 10A$$

Question 13

A bullet of mass m hits a mass M and gets embedded in it. If the block rises to a height h as a result of this collision, the velocity of the bullet before collision is

Options:

A. $a \cdot v = \sqrt{2gh}$

B. $v = \sqrt{2gh} \left[1 + \left(\frac{m}{M} \right) \right]$

C. $v = \sqrt{2gh} \left(1 + \sqrt{\frac{M}{m}} \right)$

D. $v = \sqrt{2gh} \left[1 - \left(\frac{m}{M} \right) \right]$

Answer: C

Solution:

Solution:

Let the velocity of the bullet before collision be v , then according to law of conservation of linear momentum,

$$mv = (m + M)v' \dots\dots\dots(i)$$

As the mass m of the bullet gets embedded in the wall, hence velocity of bullet + target just after collision will be same,

$$\frac{1}{2}(M + m)v'^2 = (m + M)gn$$

$$\Rightarrow v' = \sqrt{2gh}$$

Putting the value of v' in Eq.(i), we get

$$\Rightarrow v = \sqrt{2gh} \frac{(m + M)}{m} = \sqrt{2gh} \left(1 + \frac{M}{m} \right)$$

Question 14

A particle of mass m is moving in a horizontal circle of radius r under a centripetal force given by $\left(\frac{-K}{r^2} \right)$, where K is a constant. Then

Options:

A. the total energy of the particle is $\left(\frac{-K}{2r} \right)$

B. the kinetic energy of the particle is $\left(\frac{K}{r} \right)$

C. the potential energy of the particle is $\left(\frac{K}{2r} \right)$

D. the kinetic energy of the particle is $\left(\frac{-K}{r} \right)$

Answer: A**Solution:****Solution:**

The potential energy is given by

$$U = \int F \cdot dr = \int \frac{K}{r^2} dr = K \int r^{-2} dr$$

$$= K \left[\frac{r^{-1}}{-1} \right] = \frac{-K}{r}$$

The kinetic energy is given by

$$K = \frac{1}{2}mv^2 = \frac{1}{2} \left(\frac{K}{r} \right) \left[\because \frac{mv^2}{4} = \frac{K}{r^2} \right]$$

Total energy, $E = U + K$

$$= -\frac{K}{r} + \frac{K}{2r} = \frac{-K}{2r}$$

Question 15

The height at which the acceleration due to gravity becomes $\frac{g}{16}$ (where, g = acceleration due to gravity on the surface of the earth) in terms of R is, if R is the radius of earth.

Options:

- A. $2R$
- B. $3R$
- C. $\sqrt{2}R$
- D. $\sqrt{3}R$

Answer: B

Solution:

Solution:

As, acceleration due to gravity at height h ,

$$g' = \frac{GM}{(R+h)^2}$$

$$\Rightarrow \frac{g}{16} = \frac{GM}{R^2} \left(\frac{R^2}{(R+h)^2} \right) = g \frac{R^2}{(R+h)^2} \left(\because g = \frac{g}{16} \right)$$

$$\Rightarrow \frac{1}{4} = \frac{R}{R+h} \Rightarrow h = 3R$$

Question 16

Which of the following series spectrum of hydrogen atom lies in ultraviolet region?

Options:

- A. Paschen series
- B. Brackett series
- C. Pfund series
- D. Lyman series

Answer: D

Solution:

Solution:

Lyman series lies in the ultraviolet region whereas Paschen, Brackett and Pfund series lie in the infrared region.

Question 17

Speed of electromagnetic wave in a medium having relative permittivity ϵ_r and relative permeability μ_r is (speed of light in air, $c = 3 \times 10^8 \text{ m / s}$)

Options:

- A. $\frac{1}{\sqrt{\mu_r \epsilon_r}}$

B. $\frac{c}{\sqrt{\mu_r \epsilon_r}}$

C. $c \sqrt{\frac{\mu_r}{\epsilon_r}}$

D. $\frac{c}{\mu_r \epsilon_r}$

Answer: B

Solution:

Solution:

Speed of EM wave in medium is given as

$$v = \frac{c}{\sqrt{\mu_r \epsilon_r}}$$

Question 18

The wavelength of the second line of Balmer series is 486.4 nm. What is the wavelength of the first line of Lyman series?

Options:

A. 78.8 nm

B. 121.6 nm

C. 418.2 nm

D. 610.5 nm

Answer: B

Solution:

Solution:

Wavelength in Balmer series for hydrogen are given by

$$\frac{1}{\lambda} = R_H \left(\frac{1}{2^2} - \frac{1}{n^2} \right)$$

$$= R_H \left(\frac{1}{4} - \frac{1}{n^2} \right), n = 3, 4, 5, \dots$$

The second line in Balmer series corresponds to $n=4$

$$\text{Hence, } \frac{1}{\lambda_2} = R_H \left(\frac{1}{4} - \frac{1}{16} \right) = \frac{3R_H}{16}$$

$$\text{or, } \lambda_2 = \frac{16}{3R_H}$$

The wavelength of the first line ($n=2$) in Lyman series is

$$\frac{1}{\lambda_1} = R_H \left(1 - \frac{1}{2^2} \right) = R_H \left(1 - \frac{1}{4} \right) = \frac{3R_H}{4}$$

$$\text{or, } \lambda_1 = \frac{4}{3R_H}$$

$$\therefore \frac{\lambda_1}{\lambda_2} = \frac{4}{3R_H} \times \frac{3R_H}{16} = \frac{1}{4}$$

$$\Rightarrow \lambda_1 = \frac{\lambda_2}{4} = \frac{486.4}{4} = 121.6 \text{ nm}$$

Question 19

A bat emitting an ultrasonic wave of frequency 4.5×10^4 Hz at speed of 6m / s between two parallel walls. The two frequencies heard by the bat will be

Options:

- A. 4.67×10^4 Hz, 4.34×10^4 Hz
- B. 4.34×10^4 Hz, 4.67×10^4 Hz
- C. 4.5×10^4 Hz, 5.4×10^4 Hz
- D. 4.67×10^3 Hz, 4.34×10^4 Hz

Answer: A

Solution:

Solution:

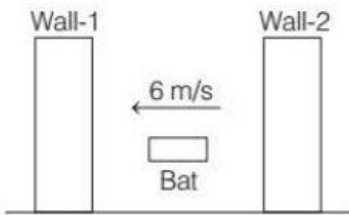

Frequency received by bat after reflection from wall - 1,

$$f_1 = f \left[\frac{v+u}{v-u} \right] = 4.5 \times 10^4 \left[\frac{330+6}{330-6} \right]$$

Given, $f = 4.5 \times 10^4$ Hz

$$\Rightarrow f_1 = 4.67 \times 10^4 \text{ Hz}$$

Frequency received by bat after reflection from wall - 2

$$\begin{aligned} f_2 &= f \left[\frac{v-u}{v+u} \right] \\ &= 4.5 \times 10^4 \left[\frac{330-6}{330+6} \right] \\ &= 4.34 \times 10^4 \text{ Hz} \end{aligned}$$

Question 20

A disc of moment of inertia $4 \text{ kg} - \text{m}^2$ revolving with 16 rad / s is placed on another disc of moment of inertia $8 \text{ Kg} - \text{m}^2$ revolving 4 rad / s . The angular frequency of composite disc

Options:

- A. 4 rad / s
- B. $\frac{3}{16} \text{ rad / s}$
- C. 8 rad / s

D. $\frac{16}{3} \text{rad / s}$

Answer: C

Solution:

Solution:

Given that, moment of inertia of disc, $I_1 = 4 \text{kg} - \text{m}^2$

$$I_2 = 8 \text{kg} - \text{m}^2$$

Angular velocities of discs,

$$\omega_1 = 16 \text{rad / s}$$

$$\omega_2 = 4 \text{rad / s}$$

From angular momentum conservation principle,

$$I_1\omega_1 + I_2\omega_2 = (I_1 + I_2)\omega$$

$$\Rightarrow 4 \times 16 + 8 \times 4 = (4 + 8)\omega$$

$$\Rightarrow 64 + 32 = 12\omega$$

$$\Rightarrow \omega = \frac{96}{12} = 8 \text{rad / s}$$

Question 21

An electric current I enters and leaves a uniform circular wire of radius r through diametrically opposite points. A charged particle q moves along the axis of circular wire passes through its centre with speed v . The magnetic force on the particle when it passes through the centre has a magnitude

Options:

A. $\frac{qv\mu_0 I}{2\pi r}$

B. $qv \frac{\mu_0 I}{\pi r}$

C. $\frac{qv\mu_0 I}{r}$

D. 0

Answer: D

Solution:

Solution:

From on a moving charged p[article in uniform magnetic field,

$$F = Bqv\sin\theta \dots (i)$$

Since, charge particle moves along the axis of circular current carrying loop, therefore, $\theta = 0^\circ$ or 180° .

When $\theta = 0^\circ$, $F = Bqv\sin 0^\circ$ [From Eq. (i)]

$$F = 0$$

When $\theta = 180^\circ$, $F = Bqv\sin 180^\circ$

$$F = 0$$

Question 22

Television frequencies are of the order of 100 MHz, while radio frequencies are of the order of 1 MHz. Using these as typical frequencies, the ratio of the emf generated in a loop antenna by a television wave to that generated by a radio wave, if both have equal electric field intensities.

Options:

- A. 1
- B. 10
- C. 100
- D. 66.6

Answer: C

Solution:

Solution:

As we know that, emf induced $e = \frac{d\phi_B}{dt}$

ore $= \frac{dB}{dt}$ (When area is constant $\phi_B \propto B$)

Now for television wave, $e_1 = \frac{d}{dt}(B)$

$$= \frac{d}{dt}(B_0 \sin(2\pi f_1 t + \phi))$$

$$e_1 = B_0 2\pi f_1 \cos(2\pi f_1 t + \phi)$$

For radiowave, $e_2 = \frac{d}{dt}(B)$

$$= \frac{d}{dt}(B_0 \sin(2\pi f_2 t + \phi))$$

The ratio of emf induced

$$= \frac{e_1}{e_2} = \frac{B_0 2\pi f_1 \cos(2\pi f_1 t + \phi)}{B_0 2\pi f_2 \cos(2\pi f_2 t + \phi)}$$

Since, $f_1 = 100 \text{ MHz}$, $f_2 = 1 \text{ MHz}$

and $\cos(2\pi f_1 t + \phi) = \cos(2\pi f_2 t + \phi) = \cos\phi$ (For complete cycle)

$$\text{We get, } \frac{e_1}{e_2} = \frac{100}{1} = 100$$

Question 23

A particle is performing simple harmonic motion. Equation of its motion

is $x = 5 \sin \left(4t - \frac{\pi}{6} \right)$, x being the displacement from mean position.

Velocity (in ms^{-1}) of the particle at the instant when its displacement is 3, will be

Options:

- A. $\frac{2\pi}{3}$
- B. $\frac{5\pi}{6}$

C. 20

D. 16

Answer: D

Solution:

Solution:

According to the question,

$$x = 5\sin\left(4t - \frac{\pi}{6}\right)$$

When $x = 3$

$$\Rightarrow \frac{3}{5} = \sin\left(4t - \frac{\pi}{6}\right)$$

$$\Rightarrow 4t - \frac{\pi}{6} = 37^\circ$$

$$\text{Hence, velocity} = \frac{dx}{dt} = 5 \times 4\cos\left(4t - \frac{\pi}{6}\right)$$

$$= 5 \times 4\cos\left(4t - \frac{\pi}{6}\right)$$

$$= 5 \times 4 \times \cos 37^\circ$$

$$= 16\text{ms}^{-1} \left(\because \cos 37^\circ = \frac{4}{5}\right)$$

Question 24

A raft of density $600\text{g} / \text{m}^3$ and mass 120 kg floats in water. How much weight can be put on the raft to make it just sink?

Options:

A. 120 kg

B. 200 kg

C. 40 kg

D. 80 kg

Answer: D

Solution:

Solution:

$$\text{Volume of wood} = \frac{\text{Mass}}{\text{Density}}$$

$$= \frac{120}{600} = 0.2\text{m}^3$$

Weight of displaced water,

$$vdg = 0.2 \times 1000 \times 10 = 2000\text{N}$$

$$Mg = vdg$$

$$\Rightarrow (120 + m)g = 2000$$

$$\Rightarrow m = 80\text{kg}$$

Question 25

The displacement x of a particle in a straight line motion is given by $x = 1 - t - t^2$. The correct representation of the motion is

Options:

A.

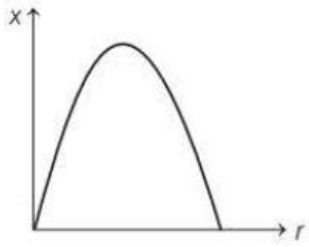

B.

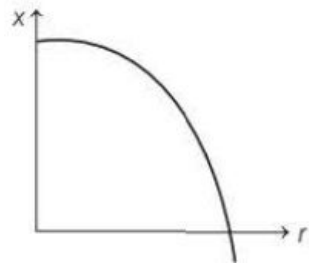

C.

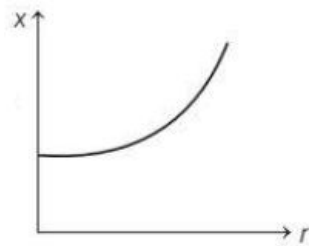

D.

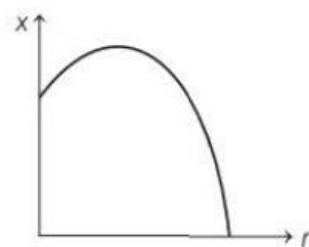

Answer: B

Solution:

Solution:

If we differentiate the equation of motion, $x = 1 - t - t^2$ w. x. t. time, we get velocity.

$$v = \frac{dx}{dt} = -1 - 2t$$

Comparing with $v = u + at$, we have $u = -1\text{ms}^{-1}$ and $a = -2\text{ms}^{-2}$

At $t = 0$, $x = 1\text{m}$. Then, u and a both are negative.

Hence, x -coordinate of particle will go on decreasing.

Question 26

A galvanometer having a resistance of 4Ω is shunted by a wire of resistance 2Ω . If the total current is 1.5A , the current passing through shunt is

Options:

- A. 1.25A
- B. 1A
- C. 0.75A
- D. 0.5A

Answer: B

Solution:

Solution:

From figure,

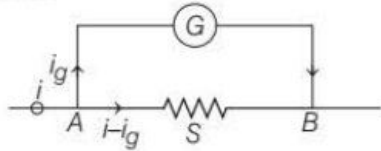

Shunt current = $i - i_g$
galvanometer current = i_g

i = total current

$\therefore i = 1.5\text{A}$

By KVL,

$$i_g - G = (i - i_g)S$$

Putting $G = 4\Omega$ and $S = 2\Omega$ and $i = 1.5\text{A}$

$$\therefore i_g \times 4 = (1.5 - i_g) \times 2$$

$$4i_g = 3 - 2i_g$$

$$6i_g = 3 \Rightarrow i_g = 0.5\text{A}$$

\therefore Current passing through shunt = $i - i_g$
 $= 1.5 - 0.5 = 1\text{A}$

Question 27

In Young's double slit experiment, the two slits are separated by 0.2 mm and they are 1m from the screen. The wavelength of the light used is 500 nm . The distance between 6th maxima and 10th minima on the screen is closest to

Options:

- A. 12 mm
- B. 10 mm
- C. 14 mm
- D. 8 mm

Answer: D

Solution:

Solution:

Given, $d = 0.2\text{mm} = 2 \times 10^{-4}\text{m}$

$D = 1\text{m}$, $\lambda = 500\text{nm} = 5 \times 10^{-7}\text{m}$

The distance between 6th maxima and 10th minima is given as

$$\Delta x = (x_{10})_{\text{dark}} - (x_6)_{\text{bright}}$$
$$= \frac{(2 \times 10 - 1)D\lambda}{2d} - \frac{6D\lambda}{d}$$

$$= \frac{D\lambda}{d} \left[\frac{19}{2} - 6 \right]$$

$$= \frac{1 \times 5 \times 10^{-7}}{2 \times 10^{-4}} \left[\frac{7}{2} \right] = \frac{35}{4} \times 10^{-3}\text{m}$$

$$= 8.75 \times 10^{-3}\text{m}$$

$$= 8.75\text{nm}$$

Hence, 8mm is closest to 8nm.

Question 28

A series L – C – R circuit is connected to an AC source of 220V and 50 Hz shown in figure. If the readings of the three voltmeters V_1 , V_2 and V_3 are 65V, 415V and 204V respectively, the value of inductance and capacitance will be

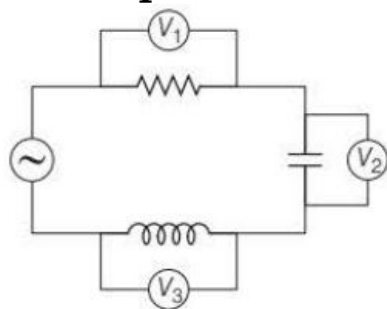

Options:

- A. 2.0H, 5 μ F
- B. 1.0H, 5 μ F
- C. 4.0H, 6 μ F
- D. 1.0H, 2 μ F

Answer: B

Solution:

Solution:

As $V = I_{\text{rms}}R$

$$I_{\text{rms}} = \frac{V_R}{R} = \frac{65}{100} = 0.65\text{A}$$

$$V_L = I_{\text{rms}} \times X_L$$

$$X_L = \frac{V_L}{I_{\text{rms}}} = \frac{204}{0.65} = 313.85\Omega$$

$$X_L = \omega L = 2\pi f L$$

$$\text{or } L = \frac{X_L}{2\pi f}$$

$$L = \frac{313.85}{2 \times \pi \times 50} = 1.0\text{H}$$

$$X_C = \frac{V_C}{I_{\text{rms}}} = \frac{415}{0.65} = 638.46\Omega$$

$$X_C = \frac{1}{\omega C} = \frac{1}{2\pi f C}$$

$$C = \frac{1}{2 \times \pi \times 50 \times 638.46}$$

$$= 5 \times 10^{-6} = 5\mu\text{F}$$

Question 29

A regular hexagon of side m which is a wire of length 24m is coiled on that hexagon. If current in hexagon is I , then the magnetic moment,

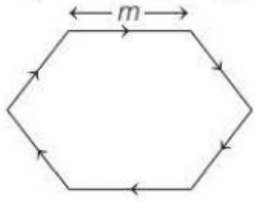

Options:

A. $6\sqrt{3}Im^2$

B. $3\sqrt{3}Im^2$

C. $\frac{3\sqrt{3}}{2}Im^2$

D. $6Im^2$

Answer: A

Solution:

Solution:

Let number of turns of the regular hexagon = n

Now, $n \times 6m = 24\text{m}$

$\therefore n = 4$

Magnetic moment, $M = nIA = 4IA$

\therefore Area of hexagon

$$= \frac{1}{2}m^2\sin^2 60^\circ + m \cdot 2m\sin 60^\circ + \frac{1}{2}m^2\sin 120^\circ$$

$$= \frac{\sqrt{3}}{4}m^2 + \sqrt{3}m^2 + \frac{\sqrt{3}m^2}{4}$$

$$= \frac{6\sqrt{3}m^2}{4} = \frac{3\sqrt{3}m^2}{2}$$

Hence, magnetic moment = $4I \left(\frac{3\sqrt{3}m^2}{2} \right)$

$$= 6\sqrt{3}Im^2$$

Question 30

Which of the following gate give the similar output as the output of

circuit diagram shown in the figure?

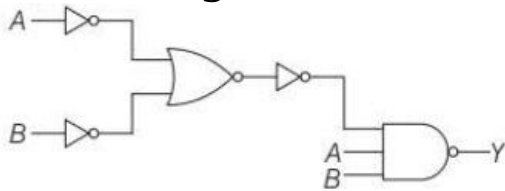

Options:

- A. AND gate
- B. OR gate
- C. NOR gate
- D. NAND gate

Answer: A

Solution:

Solution:

From the given circuit diagram, output γ is given as

$$\begin{aligned}\gamma &= (A + B)AB \\ &= (A \cdot B)AB \text{ [By De Morgan's law, } A + B = A \cdot B \text{]} \\ &= (AB)(AB) \text{ [}\because A \cdot A = A \text{]} \\ &= AB \\ &= \text{output of AN D gate.}\end{aligned}$$

Question 31

Water is poured in a tank through a cylindrical tube of area of cross-section A and ejecting water at a constant speed 4m / s . The tank contains a hole of area $\frac{A}{2}$ at bottom. Level of water in the tank will not go up beyond

Options:

- A. 5.6m
- B. 4.8m
- C. 3.2m
- D. 1.8m

Answer: C

Solution:

Solution:

According to fluid dynamics, for maximum level of water in tank,

$$A_1v_1 = A_2v_2$$

Given, $A_1 = A$,

velocity, $v_1 = 4\text{ms}^{-1}$

$$\begin{aligned} \text{area of hole } A_2 &= \frac{A}{2} \\ \Rightarrow A \times 4 &= \frac{A}{2} \times \sqrt{2gh} \\ \Rightarrow 16 &= \frac{2gh}{4} \\ \Rightarrow h &= \frac{16 \times 4}{2 \times 10} = 3.2\text{m} \end{aligned}$$

Question 32

If R and C denote resistance and capacitance of a material, then the dimension of CR will be :

Options:

- A. $[ML^0T]$
- B. $[M^0L^0T]$
- C. $[M^0L^0T^2]$
- D. $[M^2L^0T]$

Answer: B

Solution:

Solution:

The capacitance of a conductor is defined as the ratio of the charge given to the rise in the potential of the conductor.

$$C = \frac{q}{V} = \frac{q^2}{W} \left(V = \frac{W}{q} \right)$$

$$C = \frac{\text{ampere}^2 - \text{second}^2}{\text{kg}^2 - \text{metre}^2 \text{second}^{-2}}$$

Hence, dimensionally $[M^{-1}L^{-2}T^4A^2]$

From Ohm's law, $V = IR$,

$$\text{Hence, } R = \frac{V}{I} = \frac{V \text{ ol t}}{\text{Ampere}} = \frac{W}{q} \times \frac{t}{q}$$

$$R = \frac{F \times s \times t}{q^2} = \text{kg} \frac{\text{m}}{\text{s}^2} \times \frac{\text{m} \times \text{s}}{\text{A}^2 \times \text{s}^2}$$

$$= \text{kgm}^2\text{s}^{-3}\text{A}^{-2}$$

Dimensionally, $R = [ML^2T^{-3}A^{-2}]$

Hence, $CR = [M^{-1}L^{-2}T^4A^2][ML^2T^{-3}A^{-2}]$

$$= [M^0L^0T]$$

Question 33

An ideal gas is taken through the cycle $A \rightarrow B \rightarrow C \rightarrow A$, as shown in the figure. If the net heat supplied to the gas in the cycle is 5J, the work done by the gas in the process $C \rightarrow A$ is,

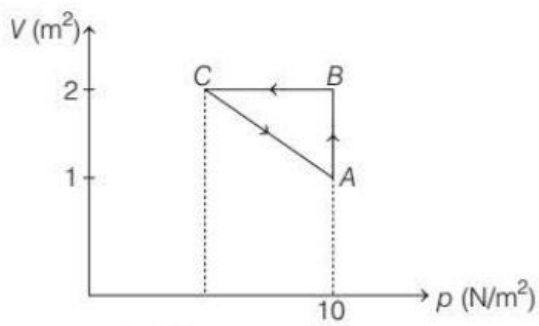

Options:

- A. -5J
- B. -10J
- C. -15J
- D. -20J

Answer: A

Solution:

Solution:

Net work done by a gas,

$$\Delta W_{AB} = p \cdot \Delta V = 10 \times (2 - 1) = 10\text{J}$$

$$\Delta W_{BC} = 0 \text{ (as } V = \text{constant)}$$

From first law of thermodynamics,

$$\text{we have, } \Delta Q = \Delta W + \Delta U$$

$$U = 0$$

(process ABCA is cyclic)

$$\text{Therefore, } \Delta Q = \Delta W_{AB} + \Delta W_{BC} + \Delta W_{CA}$$

$$\therefore \Delta W_{CA} = (\Delta Q - W_{AB} - W_{BC})$$

$$= (5 - 10 - 0)\text{J} = -5\text{J}$$

Question 34

From a circular disc of radius R , a square is cut out with a radius as its diagonal. The centre of mass of remaining portion is at a distance (from the centre)

Options:

A. $\frac{R}{(4\pi - 2)}$

B. $\frac{R}{2\pi}$

C. $\frac{R}{\pi - 2}$

D. $\frac{R}{2\pi - 2}$

Answer: A

Solution:

Solution:

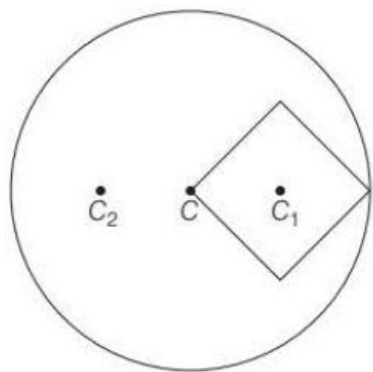

Radius of the circular disc = R

Suppose, centre of mass of remaining portion is at a distance C_2 from the C .

Now, $A_1(CC_1) = A_2(CC_2)$

For square, $(\text{side})^2 + (\text{side})^2 = (\text{radius})^2$

$$2(\text{side})^2 = R^2$$

$$(\text{side})^2 = \frac{R^2}{2}$$

$$\text{side} = \frac{R}{\sqrt{2}}$$

Now, $A_1(CC_1) = A_2(CC_2)$

$$\therefore CC_2 = \frac{A_1(CC_1)}{A_2}$$

$$A_1 = \text{area of the square} = \left(\frac{R}{\sqrt{2}}\right)^2$$

$A_2 =$ area of the remaining part of the circle

$$= \pi R^2 - \left(\frac{R}{\sqrt{2}}\right)^2$$

$$CC_2 = \frac{\left(\frac{R}{\sqrt{2}}\right)^2}{\pi R^2 - \left(\frac{R}{\sqrt{2}}\right)^2} \cdot \left(\frac{R}{2}\right)$$

$$= \frac{R^2}{2\pi R^2 - R^2} \cdot \frac{R}{2}$$

$$= \frac{R \cdot R \cdot R}{R^2(2\pi - 1)2} = \frac{R}{4\pi - 2}$$

Question 35

A bar magnet of length 6 cm, is placed in the magnetic meridian with N pole, pointing towards the geographical north. Two neutral points, separated by a distance of 8 cm are obtained on the equatorial axis of the magnet. If $B_H = 1.2 \times 10^{-5} \text{ T}$. Then the pole strength of the magnet is

Options:

A. $0.75 \text{ A} - \text{m}^2$

B. $0.25 \text{ A} - \text{m}^2$

C. $0.50 \text{ A} - \text{m}^2$

D. $1.50 \text{ A} - \text{m}^2$

Answer: B

Solution:

Solution:

At neutral point

$$B = B_H$$

$$\Rightarrow \frac{\mu_0}{4\pi} \times \frac{M}{(r^2 + l^2)^{\frac{3}{2}}} = B_H$$

$$\Rightarrow 10^{-7} \times \frac{m \times 2l}{(r^2 + l^2)^{\frac{3}{2}}} = 1.2 \times 10^{-5}$$

$$\Rightarrow 10^{-7} \times \frac{m \times 2 \times 3 \times 10^{-2}}{[(4 \times 10^{-2})^2 + (3 \times 10^{-2})^2]^{\frac{3}{2}}} = 1.2 \times 10^{-5}$$

$$\Rightarrow \frac{6m \times 10^{-4}}{3} = 1.2$$

$$\Rightarrow \frac{6m \times 10^{-4}}{125 \times 10^{-6}} = 1.2$$

$$\Rightarrow m = \frac{1.2 \times 125 \times 10^{-2}}{6} \\ = 0.25A - m^2$$

Question 36

A force F applied on the wire of radius r and length L and change in the length of the wire is l. If the same force F is applied on the wire of the same material and radius 4r and length 4l, then change in length of the other wire is,

Options:

A. $\frac{1}{4}$

B. 2l

C. $\frac{1}{2}$

D. 4l

Answer: A**Solution:****Solution:**As per formula, the Young's modulus, $\gamma = \frac{\text{stress}}{\text{strain}}$

$$= \frac{F}{\frac{\Delta l}{l}}$$

$$\Rightarrow F = \frac{\gamma A \Delta l}{l}$$

In first case, $\gamma = \frac{F}{\frac{l_1}{L}}$

$$\Rightarrow F = \frac{\gamma l_1 A_1}{L} \dots\dots\dots(i)$$

Similarly, for the second case,

$$F = \frac{\gamma l_2 A_2}{\Delta l} \dots\dots\dots(ii)$$

From Eqs. (i) and (ii), we get

$$\frac{\gamma l_1 A_1}{L} = \frac{\gamma l_2 A_2}{4L}$$

As γ is same, as the same material is taken, $l_1 A_1 = \frac{l_2 A_2}{4}$

$$l_1 \pi r^2 = \frac{l_2 \pi (4r)^2}{4}$$

$$l_1 = \frac{l_2}{4} \cdot \frac{16r^2}{r^2} = 4l_2 \Rightarrow l_2 = \frac{l_1}{4}$$

Hence, $l_1 = 1, l_2 = \frac{1}{4}$

Question 37

A 30 mW laser beam has a cross-sectional area of 15mm². The magnitude of the maximum electric field in this electromagnetic wave is

given by $\left[\begin{array}{l} \text{Permittivity of space, } \epsilon_0 = 9 \times 10^{-12} \\ \text{Speed of light, } c = 3 \times 10^8 \text{ m / s} \end{array} \right]$

Options:

- A. 1.22 kV / m
- B. 12 kV / m
- C. 10 kV / m
- D. 201 kV / m

Answer: A

Solution:

Solution:

Given, power of laser beam,

$$P = 30\text{mW} = 30 \times 10^{-3}\text{W}$$

$$\text{Area of cross section, } A = 15\text{mm}^2 = 15 \times 10^{-6}\text{m}^2$$

$$\text{Permittivity of free space, } \epsilon_0 = 9 \times 10^{-12} \text{ SI unit}$$

$$\text{Speed of light, } c = 3 \times 10^8 \text{ m / s}$$

Intensity of electromagnetic wave is given by

$$I = \frac{1}{2} n c \epsilon_0 E^2$$

where, n is refractive index for air, $n = 1$

$$I = \frac{1}{2} c \cdot \epsilon_0 E^2 \dots\dots\dots(i)$$

$$I = \frac{P}{A} \dots\dots\dots(ii)$$

From Eqs. (i) and (ii), we get

$$\frac{1}{2} c \epsilon_0 E^2 = \frac{P}{A}$$

$$E^2 = \frac{2P}{Ac \epsilon_0}$$

$$E = \sqrt{\frac{2 \times 30 \times 10^{-3}}{15 \times 10^{-6} \times 3 \times 10^8 \times 9 \times 10^{-12}}}$$

$$= 1.22 \times 10^3 \text{ V / m} = 1.22 \text{ kV / m}$$

Question 38

The average kinetic energy of a molecule in air at room temperature of 20°C

Options:

- A. $6 \times 10^{-22}\text{J}$
- B. $7.06 \times 10^{-21}\text{J}$
- C. $6.07 \times 10^{-21}\text{J}$
- D. $6.70 \times 10^{-21}\text{J}$

Answer: C

Solution:

Solution:

The average molecular kinetic energy is expressed as

$$K = \frac{1}{2}mv^2 = \frac{3}{2}kT$$

Given, $T = 20^{\circ}\text{C} = 20 + 273 = 293\text{K}$

$k = 1.38 \times 10^{-23}\text{J} / \text{K}$ = Boltzmann's constant

Substituting all the values, we get

$$\begin{aligned} K &= \frac{3}{2} \times 1.38 \times 10^{-23} \times 293 \\ &= 6.07 \times 10^{-21}\text{J} \end{aligned}$$

Question 39

Two guns P and Q can fire bullets at speeds 2 km / s and 4 km / s , respectively. From a point on a horizontal ground, they are fired in all possible directions. The ratio of maximum or areas covered by the bullets fired by the two guns, on the ground is

Options:

- A. 1 : 2
- B. 1 : 4
- C. 1 : 8
- D. 1 : 16

Answer: D

Solution:

Solution:

As for the projectile motion, horizontal range,

$$R = \frac{u^2 \sin 2\theta}{g}$$

$$\therefore \text{Maximum range} = u^2 / g$$

$$\therefore A = \pi R^2$$

$$\therefore A \propto R^2$$

$$\text{i.e., } A \propto u^2$$

$$\therefore \frac{A_1}{A_2} = \frac{u_1^4}{u_2^4} = \left(\frac{2}{4}\right)^4 = \left(\frac{1}{2}\right)^4 = \frac{1}{16}$$

Question 40

A cell of emf 2V is connected with a load of resistance 1.5Ω. The power delivered by the cell to the load is maximum, then power transferred to the load is

Options:

A. 0.33W

B. 2.67W

C. 1.33W

D. 3.25W

Answer: A

Solution:

Solution:

Given, emf of cell, $E = 2V$

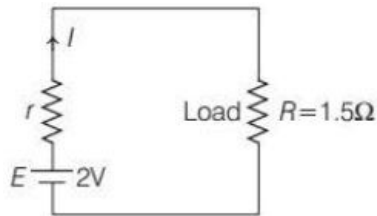

Load resistance, $R_L = 1.5\Omega$

Current flowing the circuit is

$$I = \frac{E}{R + r}$$

Power transferred to the load, R ,

$$P = I^2 R = \left(\frac{E}{R + r}\right)^2 \cdot R = \frac{E^2 R}{(R + r)^2}$$

Power P will be maximum, if

$$\frac{dP}{dR} = 0$$

$$\Rightarrow \frac{d}{dR} \frac{E^2 R}{(R + r)^2} = 0$$

$$\Rightarrow \frac{E^2 (R + r)^2 - E^2 R \cdot 2(R + r)}{(R + r)^3} = 0$$

$$\Rightarrow E^2 (R + r) [R + r - 2R] = 0$$

$$\Rightarrow E^2 (R + r) (r - R) = 0$$

$$\Rightarrow r - R = 0$$

$$\Rightarrow r = R$$

$$\therefore \text{Maximum power, } P = \frac{E^2 R}{(R + r)^2} = \frac{E^2 R}{(R + R)^2} = \frac{E^2}{4R}$$

$$\Rightarrow P = \frac{2^2}{4} \times 1.5 = \frac{1}{3} = 0.33W$$

Question 41

A plane glass mirror of thickness 3 cm of material of $\mu = \frac{3}{2}$ is silvered on the black surface. When a point object is placed 9 cm from the front surface of the mirror, then the position of the brightest image from the front surface is

Options:

- A. 9 cm
- B. 11 cm
- C. 12 cm
- D. 13 cm

Answer: D

Solution:

Solution:

A thick glass mirror produces a number of images. There is an apparent shift of actual silvered surface towards the unsilvered face.

$$\begin{aligned} \text{Effective distance of the reflecting surface from unsilvered face} &= \frac{d}{\mu} \\ &= \frac{3}{\frac{3}{2}} \text{cm} = 2 \text{cm} \end{aligned}$$

Distance of point object from effective reflecting surface
= 9 cm + 2 cm = 11 cm

Distance of image from point object
= 11 cm + 11 cm = 22 cm

Distance of image from unsilvered face
= (22 - 9) cm = 13 cm

Question 42

Ultraviolet light of wavelength 99 nm falls on a metal plate of work function 1.0 eV. If the mass of the electron is 9.1×10^{-31} kg, the wavelength of the fastest photoelectron emitted is

Options:

- A. 0.63 nm
- B. 0.66 nm
- C. 0.33 nm
- D. 0.36 nm

Answer: D

Solution:

Solution:

$$\text{Given } K_{\max} = hv - W_0$$

$$= \frac{(6.6 \times 10^{-34}) \times (3 \times 10^8)}{99 \times 10^{-9}} - 1.0 \times 1.6 \times 10^{-19}$$

$$= 2 \times 10^{-18} - 1.6 \times 10^{-19}$$

$$= 1.84 \times 10^{-18} \text{ J}$$

$$\text{Now, } \lambda = \frac{h}{\sqrt{2mK_{\max}}}$$

$$= \frac{6.6 \times 10^{-34}}{\sqrt{2 \times (9.1 \times 10^{-31}) \times 1.84 \times 10^{-18}}}$$

$$= 0.36 \times 10^{-9} \text{ m} = 0.36 \text{ nm}$$

Question 43

In Young's double slit experiment, the fringe width is found to be 0.4 mm. If the whole apparatus is immersed in a liquid of refractive index $\frac{4}{3}$ without changing geometrical arrangement, the new fringe width will be

Options:

A. 0.45 mm

B. 0.4 mm

C. 0.53 mm

D. 0.30 mm

Answer: D**Solution:****Solution:**

If fringe widths of air and water are β_{air} and β_{water} respectively, then fringe width, $\beta_{\text{water}} = \frac{\beta_{\text{air}}}{\mu}$

$$\text{Given, } \mu = \frac{4}{3}, \beta_{\text{air}} = 0.4$$

$$\text{Hence, } \beta_{\text{water}} = \frac{0.4}{\frac{4}{3}} = 0.3 \text{ mm}$$

Question 44

There are two identical containers C_1 and C_2 containing to identical gases. Gas in C_1 is reduced to half of its original volume adiabatically, while the gas in container C_2 is also reduced to half of its initial volume isothermally. Find the ratio of final pressure in these containers. (γ be the adiabatic constant).

Options:

A. 2 : 1

B. 1 : 2

C. $2^y : 1$

D. $2^{y-1} : 1$

Answer: D

Solution:

Solution:

Since, container are identical, so initial volume and pressure will be same for identical gases. For container C_1 ,

$p_1 V_1^y = p_2 V_2^y$ (adiabatic)

$$p_2 = \left(\frac{V_1}{V_2}\right)^y p_1 = \left(\frac{V_1}{\frac{V_1}{2}}\right)^y p_1 = 2^y p_1 \dots\dots(i)$$

For container C_2 ,

$p_1 V_1 = p_2' V_2$ (isothermal)

$$p_2' = \left(\frac{V_1}{V_2}\right) p_1 = \left(\frac{V_1}{\frac{V_1}{2}}\right) p_1 = 2 p_1 \dots\dots(ii)$$

From Eqs. (i) and (ii), we get

$$\frac{p_2}{p_2'} = \frac{2^y p_1}{2 p_1} = 2^{y-1} : 1$$

Question 45

If K_1 and K_2 are maximum kinetic energies of photoelectrons emitted when lights of wavelengths λ_1 and λ_2 , respectively incident on a metallic surface and $\lambda_1 = 3\lambda_2$, then

Options:

A. $K_1 > \left(\frac{K_2}{3}\right)$

B. $K_1 < \left(\frac{K_2}{3}\right)$

C. $K_1 = 2K_2$

D. $K_2 = 2K_1$

Answer: B

Solution:

Solution:

Let W_0 be the work function of the metal, then kinetic energy of photoelectrons emitted when light of wavelength λ_1 is incident will be

$$K_1 = \frac{hc}{\lambda_1} - W_0$$

$$\text{Similarly, } K_2 = \frac{hc}{\lambda_2} - W_0$$

$$\begin{aligned} \text{Now, } K_1 &= K_2 = \frac{hc}{\lambda_1} - \frac{hc}{\lambda_2} = hc \left[\frac{1}{\lambda_1} - \frac{1}{\lambda_2} \right] \\ &= hc \left[\frac{1}{3\lambda_2} - \frac{1}{\lambda_2} \right] \\ K_1 - K_2 &= \frac{-2hc}{3\lambda_2} = \frac{-2}{3}(K_2 + W_0) \\ \Rightarrow K_1 &= K_2 - \frac{2}{3}K_2 - \frac{2}{3}W_0 \\ &= \frac{K_2}{3} - \frac{2}{3}W_0 \Rightarrow K_1 < \frac{K_2}{3} \end{aligned}$$

Question 46

A car is moving with a speed of 54 km / h. If after 3 s, the driver applies brakes and it stops, then how much distance is covered by the car before coming to rest?

Options:

- A. 22.5m
- B. 20m
- C. 25m
- D. 45.2m

Answer: A

Solution:

Solution:

$$\begin{aligned} \text{Given, speed of car, } u &= 54 \text{ km / h} = 54 \times \frac{5}{18} \\ &= 15 \text{ m / s} \end{aligned}$$

Since, car stops in 3 s on applying brakes, so acceleration can be calculated from first equation of motion,

$$v = u + at \Rightarrow 0 = 15 + a(3)$$

$$\Rightarrow a = -\frac{15}{3} = -5 \text{ ms}^{-2}$$

Using second equation of motion,

$$s = ut + \frac{1}{2}at^2$$

$$= 15 \times 3 + \frac{1}{2} \times (-5) \times (3)^2$$

$$= 45 - 22.5 = 22.5 \text{ m}$$

Question 47

A source of sound emits sound waves at frequency f_0 . It is moving towards an observer with fixed speed v_s ($v_s < v$, where v is the speed of sound in air.) If the observers were to move towards the source with speed v_0 , one of the following two graphs (A and B) will give the correct variation of the frequency f heard by the observer as v_0 is change

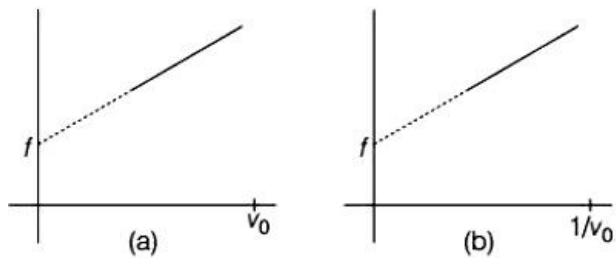

The variation of f with v_0 is given correctly by

Options:

A. graph A with slope = $\frac{f_0}{(v + v_s)}$

B. graph B with slope = $\frac{f_0}{(v - v_s)}$

C. graph A with slope = $\frac{f_0}{(v - v_s)}$

D. graph B with slope = $\frac{f_0}{(v + v_s)}$

Answer: C

Solution:

Solution:

According to Doppler's effect, the apparent frequency of sound when both source and observer are moving towards each other

$$\Rightarrow f = \frac{(v + v_0)f_0}{(v - v_s)}$$

$$\Rightarrow f = \left(\frac{v}{v - v_s}\right)f_0 + \left(\frac{v_0}{v - v_s}\right)f_0$$

$$\Rightarrow f = \left(\frac{f_0}{v - v_s}\right)v_0 + \left(\frac{f_0}{v - v_s}\right)v$$

Equation of straight line, $y = mx + c$ which is equation of straight line making an intercept c on Y -axis,

Slope of the graph = $\frac{f_0}{v - v_s}$ and intercept = $\frac{vf_0}{v - v_s}$

This condition is represented in graph A plotted between f and v_0 .

Hence, option (c) is correct.

Question 48

In which mode of transmission, the heat waves travel along straight line with the speed of light?

Options:

A. Thermal radiation

B. Forced convection

C. Natural convection

D. Thermal conduction

Answer: A

Solution:

Solution:

The energy emitted by a body, in the form of radiation on account of its temperature, is called thermal radiation. These radiations are heat radiations and travel along straight lines with speed of light.

Question 49

The escape velocity of a projectile on the earth's surface is 11.2 km / s. A body is projected out with thrice this speed. The speed of the body far away from the earth will be

Options:

A. 22.4 km / s

B. 31.7 km / s

C. 33.6 km / s

D. None of these

Answer: B

Solution:

Solution:

By the law of conservation of energy,

$$(U + K)_{\text{surface}} = (U + K)_{\infty}$$

$$\Rightarrow -\frac{GM}{R} + \frac{1}{2}m(3v_c)^2 = 0 + \frac{1}{2}mv^2$$

$$\Rightarrow -\frac{GM}{R} + \frac{9v_c^2}{2} = \frac{1}{2}v^2$$

$$\text{Since, } v_c^2 = \frac{2GM}{R}$$

$$\therefore \frac{-v_c^2}{2} + \frac{9v_c^2}{2} = \frac{1}{2}v^2$$

$$\Rightarrow v^2 = 8v_c^2$$

$$v = 2\sqrt{2}v_c = 2\sqrt{2} \times 11.2 = 31.7 \text{ km / s}$$

Question 50

Consider a compound slab consisting of two different materials having equal lengths, thickness and thermal conductivities K and 2K respectively. The equivalent thermal conductivity of the slab is

Options:

A. $\sqrt{2}K$

B. 3K

C. $\frac{4}{3}K$

D. $\frac{2}{3}K$

Answer: C

Solution:

Solution:

Equivalent thermal conductivity of the compound slab,

$$K_{eq} = \frac{l_1 + l_2}{\frac{l_1}{K_1} + \frac{l_2}{K_2}} = \frac{1 + 1}{\frac{1}{K} + \frac{1}{2K}} = \frac{2l}{\frac{3l}{2K}} = \frac{4K}{3}$$

Question 51

A circular coil of 20 turns and radius 10 cm is placed in a uniform magnetic field of 0.10T normal to the plane of the coil. If the current in the coil is 5A, then the average force on each electron in the coil due to the magnetic field is

Options:

A. $2.5 \times 10^{-25}N$

B. $4.5 \times 10^{-25}N$

C. $5 \times 10^{-25}N$

D. $5.5 \times 10^{-25}N$

Answer: C

Solution:

Solution:

Magnetic Lorenz force acting on each electron,

$$F = evB \dots \dots \dots (i)$$

As, current, $i = neAv$

$$ev = \frac{i}{nA}$$

Therefore, substituting value of ev into Eq.(i),

$$F = \frac{i}{nA}B$$

Given, $i = 5A$, $n = 20$ turns, $B = 0.1T$

$$F = evB = \frac{iB}{nA} = \frac{5 \times 0.1}{10^{29} \times 10^{-5}} = 5 \times 10^{-25}N$$

Question 52

With what minimum acceleration can a fireman slide down a rope while breaking strength of the rope is $\frac{2}{3}$ of the weight?

Options:

A. $\frac{2}{3}g$

B. g

C. $\frac{1}{3}g$

D. zero

Answer: C**Solution:****Solution:**

If a man slides down with some acceleration, then its apparent weight decreases. For critical condition, rope can bear only $\frac{2}{3}$ of his weight. If a is the minimum acceleration, then tension in the rope

$$= m(g - a) = \text{breaking strength}$$

$$\Rightarrow m(g - a) = \frac{2}{3}mg$$

$$\Rightarrow a = g - \frac{2g}{3} = \frac{g}{3}$$

Question 53

The string of length 2m is fixed at both ends. If the string vibrates in its fourth normal mode with a frequency of 500 Hz, then the waves would travel on it with a velocity of

Options:

A. 125m / s

B. 250m / s

C. 500m / s

D. 1000m / s

Answer: C**Solution:****Solution:**

In general, n th mode of a string fixed at ends has frequency,

$$v = \frac{nv}{2l}$$

where, $n = 1, 2, 3, \dots$

where, v is the velocity of wave and l is the length of string.

In fourth normal mode, $n = 4$

$$v = \frac{4v}{2l}$$

Given, $v = 500 \text{ Hz}$, $l = 2 \text{ m}$

$$\text{Hence, } 500 = \frac{4v}{2 \times 2}$$

$$\text{or, } v = \frac{500 \times 4}{4} = 500 \text{ m / s}$$

Question 54

An alternating voltage $= 200\sin 100t$ is applied to a series combination of $R = 30\Omega$ and an inductor of 400 mH . The power factor of the circuit is,

Options:

- A. 0.01
- B. 0.6
- C. 0.05
- D. 0.042

Answer: B

Solution:

Solution:

As we know,

$$\text{power factor} = \frac{R}{Z}$$

$$= \frac{R}{\sqrt{R^2 + \omega L^2}}$$

Given $\omega = 100$, $L = 400\text{mH}$

$$= \frac{30}{\sqrt{(30)^2 + (100 \times 400 \times 10^{-3})^2}}$$

$$= \frac{30}{\sqrt{900 + 160000 \times 10^{-3 \times 2}}}$$

$$= \frac{30}{59} = 0.6$$

Question 55

In the network shown in figure, the equivalent capacitance between points P and Q is

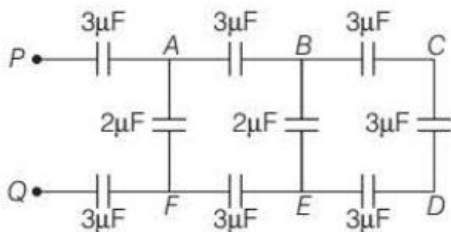

Options:

- A. $1\mu\text{F}$
- B. $2\mu\text{F}$
- C. $3\mu\text{F}$
- D. $4\mu\text{F}$

Answer: A

Solution:

Solution:

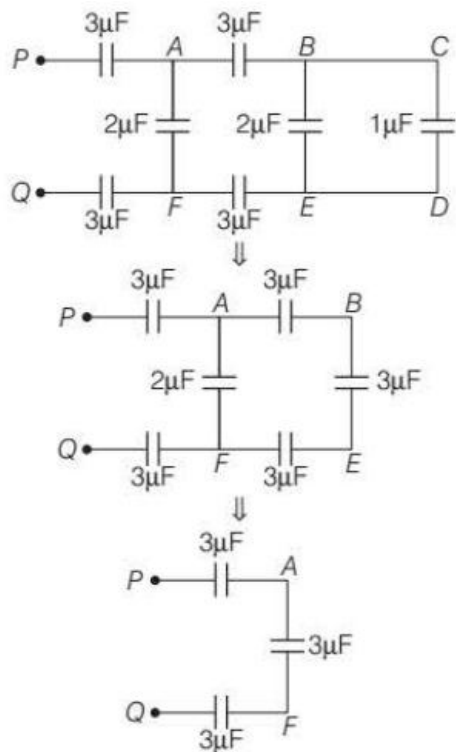

The equivalent capacitance between P and Q is given by

$$\frac{1}{C_{eq}} = \frac{1}{3} + \frac{1}{3} + \frac{1}{3} = 1\mu F$$

$$C_{eq} = 1\mu F$$

Question 56

The resultant of two forces acting at an angle of 120° is 10 kg-W and is perpendicular to one of the forces. That force is

Options:

A. $\frac{10}{\sqrt{3}} \text{ kg} - \text{W}$

B. $10 \text{ kg} - \text{W}$

C. $20\sqrt{3} \text{ kg} - \text{W}$

D. $10\sqrt{3} \text{ kg} - \text{W}$

Answer: A

Solution:

Solution:

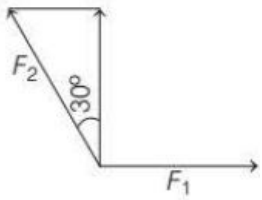

From the diagram we get,

$$\tan 30^\circ = \frac{1}{\sqrt{3}} = \frac{x}{10}$$

$$\Rightarrow x = \frac{10}{\sqrt{3}}$$

Question 57

Choose the incorrect statements.

Options:

- A. Silicon is used in the fabrication of LED.
- B. LED works on the principle of electroluminescenc
- C. LED is a power efficient device.
- D. LED is fabricated with direct band gap semiconductor.

Answer: A

Solution:

Solution:

The most commonly used material in LEDs is gallium arsenide.

Question 58

Charge on electron is

Options:

- A. $3.2 \times 10^{-19}\text{C}$
- B. $1.6 \times 10^{-19}\text{C}$
- C. $-1.6 \times 10^{-19}\text{C}$
- D. $-3.2 \times 10^{-19}\text{C}$

Answer: C

Solution:

Solution:

Charge on electron is negative and its magnitude is $1.6 \times 10^{-19}\text{C}$

Question 59

Two charged spheres of $-20\mu\text{C}$ and $60\mu\text{C}$ are kept at a certain distance. They are touched and kept again at the same distance. What is the ratio of force experienced before and after?

Options:

- A. 1 : 3
- B. 3 : 1
- C. 2 : 1
- D. 1 : 2

Answer: B

Solution:

Solution:

Given, $q_1 = -20\mu\text{C} = -2 \times 10^{-5}\text{C}$

$q_2 = 60\mu\text{C} = 6 \times 10^{-5}\text{C}$

Force of attraction between the both charges, kept at a certain distance r

$$\begin{aligned}F_1 &= \frac{K q_1 q_2}{r^2} \\&= \frac{K \times 2 \times 10^{-5} \times 6 \times 10^{-5}}{r^2} \\&= \frac{12 \times 10^{-10} K}{r^2}\end{aligned}$$

When both charges are touched, then new charge on both spheres,

$$\begin{aligned}q_1' &= q_2' = \frac{q_1 + q_2}{2} = \frac{-20 + 60}{2} = 20\mu\text{C} \\&= 2 \times 10^{-5}\text{C}\end{aligned}$$

\therefore Force between the two spheres,

$$\begin{aligned}F_2 &= \frac{K q_1' \cdot q_2'}{r^2} \\&= \frac{K \cdot 2 \times 10^{-5} \times 2 \times 10^{-5}}{r^2} \\&= \frac{4 \times 10^{-10}}{r^2} K\end{aligned}$$

$$\therefore \frac{F_1}{F_2} = \frac{\frac{12 \times 10^{-10} K}{r^2}}{\frac{4 \times 10^{-10}}{r^2}} = \frac{12}{4} = \frac{3}{1}$$

$$\therefore F_1 : F_2 = 3 : 1$$

Question 60

The AC voltage across a resistance can be measured using a

Options:

- A. hot wire voltmeter
- B. moving coil galvanometer

- C. potential coil galvanometer
- D. moving magnet galvanometer

Answer: B

Solution:

Solution:

An AC voltage across a resistance can be measured by using a moving coil galvanometer. It can be used as a voltmeter by inserting a resistor in series with it. It responds only to direct current. Hence, it requires a rectifier, so that coil deflects only in one direction.

Question 61

..... is unstable at cooking temperature, whereas the control of sweetness of food is difficult while using

Options:

- A. Alitame and aspartame
- B. Aspartame and sucralose
- C. Aspartame and alitame<
- D. Alitame and sucralose

Answer: C

Solution:

Solution:

Use of **aspartame** is limited to cold foods because it is unstable at cooking temperature.

Alitame is more stable than aspartame but the control of sweetness of food is difficult while using it.

Question 62

The chemical formula of Lucas reagent is

Options:

- A. Anhy. $\text{ZnCl}_2 / \text{HCl}$
- B. $\text{C}_6\text{H}_5\text{SO}_2\text{Cl}$
- C. $\text{NaOH} + \text{CaO}$
- D. HNO_2

Answer: A

Solution:

Solution:

Lucas reagent: Anhyd. $\frac{\text{ZnCl}_2}{\text{HCl}}$. It is used to differentiate 1°, 2° and 3° alcohols.

Question 63

Give the correct order of acidity of

Options:

A. $\text{HClO}_4 < \text{HClO}_3 < \text{HClO}_2 < \text{HClO}$

B. $\text{HClO} < \text{HClO}_2 < \text{HClO}_3 < \text{HClO}_4$

C. $\text{HClO}_4 < \text{HClO}_2 < \text{HClO} < \text{HClO}_3$

D. $\text{HClO} < \text{HClO}_3 < \text{HClO}_2 < \text{HClO}_4$

Answer: B

Solution:**Solution:**

Acidic strength of oxo-acids containing the same halogen are in the order :

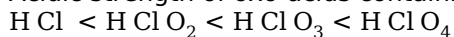

This is because ClO_4^- is the most stable due to dispersal of negative charge on four D-atoms (O being more electromagnetic than Cl).

Question 64

The process of aggregation of colloidal particles into an insoluble precipitate by the addition of suitable electrolyte is called

Options:

A. coagulation

B. diffusion

C. peptisation

D. electrolysis

Answer: A

Solution:**Solution:**

Coagulation The process of aggregation of colloidal particles into an insoluble precipitate by the addition of suitable electrolyte.

Diffusion The process of movement of molecules from a region of higher concentration to a region of lower concentration.

Peptisation The process of converting a precipitate into colloidal sol by shaking it with dispersion medium in the presence of small amount of electrolyte.

Electrolysis The process by which electric current is passed through a substance to effect a chemical change.

Question 65

Alkyl halides undergoing S_N2 reaction do inverse

Options:

- A. racemic mixture
- B. retention of configuration
- C. formation of carbocation
- D. inversion of configuration

Answer: D

Solution:

Solution:

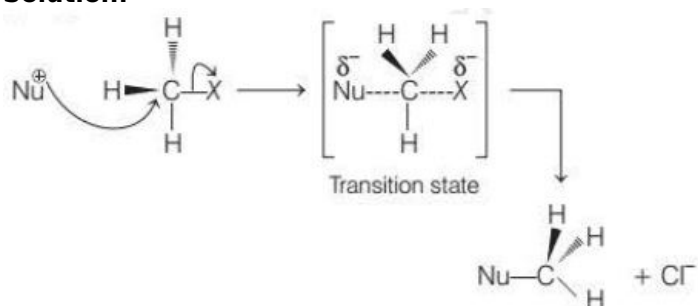

Inversion of configuration takes place. There is no carbocation formation.

Question 66

X and Y in the following reactions are

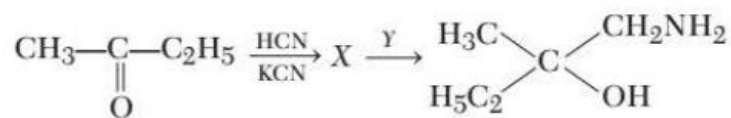

Options:

A.

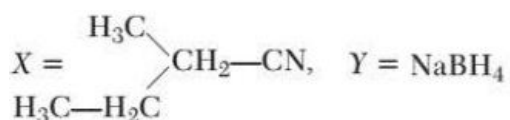

B.

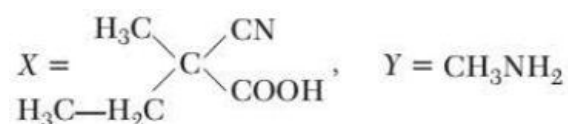

C.

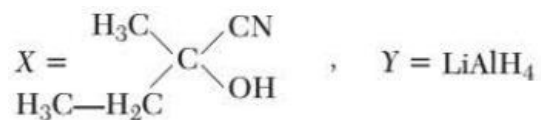

D.

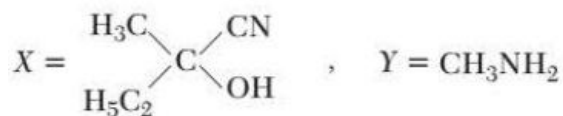

Answer: C

Solution:

Solution:

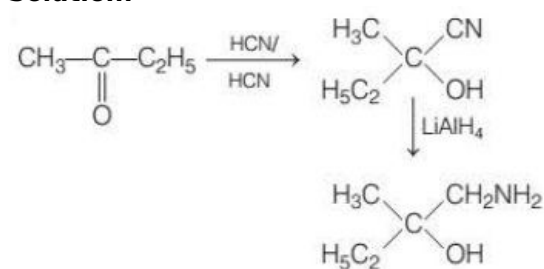

Question 67

Doping of silicon (Si) with indium (In) leads to the formation of

Options:

- A. n-type semiconductor
- B. metal
- C. p-type semiconductor
- D. insulator

Answer: C

Solution:

Solution:

Doping Si with In or B leads to the formation of p-type semiconductors.

In p-type semiconductors, trivalent impurities are used for doping, whereas, in n-type semiconductors, pentavalent impurities are used for doping.

Question 68

For the reaction, $\text{H}_2(\text{g}) + \text{I}_2(\text{g}) \rightleftharpoons 2\text{HI}(\text{g})$ the position of equilibrium can be shifted to the right by

Options:

- A. addition of HI
- B. addition of both I_2 and HI
- C. increasing temperature
- D. addition of I_2

Answer: D

Solution:**Solution:**

According to Le-Chatelier's principle when concentration of reactant increases, the equilibrium shifts in favour of forward reaction.

Question 69

Which of the following are not path functions?

- I. $H - TS$
- II. W
- III. q
- IV. $q + W$

Options:

- A. I and III
- B. I, II, IV
- C. II, III and IV
- D. I and IV

Answer: D

Solution:**Solution:**

Thermodynamic parameters which depend only on the initial and final states of system are called state functions, such as enthalpy ($H = q + W$), Gibb's free energy ($G = H - TS$).

Whereas, thermodynamic parameters which depend on the path by which the process is performed and not on initial and final states, are called path functions, such as work done (W), heat (q) etc.

Question 70

The system that forms maximum boiling azeotropes is

Options:

- A. acetone-chloroform

B. ethyl alcohol-water

C. benzene-toluene

D. CS₂ + acetone

Answer: A

Solution:

Solution:

When the non-ideal binary solution shows the negative deviation, it is known as a maximum boiling azeotrope e.g. acetone-chloroform. Rest all three options show positive deviation from Raoult's law.

Question 71

KMnO₄ acts as an oxidising agent in acidic medium. The number of moles of KMnO₄ that will be required to react with one mole of oxalate ions (to form CO₂) in acidic solution is

Options:

A. $\frac{2}{5}$

B. $\frac{5}{2}$

C. 5

D. $\frac{5}{4}$

Answer: A

Solution:

Solution:

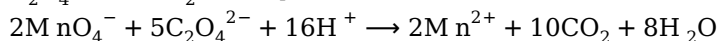
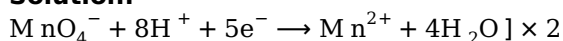

5 moles of C₂O₄²⁻ need 2 moles of KMnO₄.

1 mole of C₂O₄²⁻ would need = $\frac{2}{5}$ mole of KMnO₄.

Question 72

What can be A and B in the following reaction?<

Options:

A. HBr al

- B. KOH
C. HBr, Peroxide alc. KOH
D. HBr, Peroxide aq. KOH, Δ

Answer: C

Solution:

Solution:

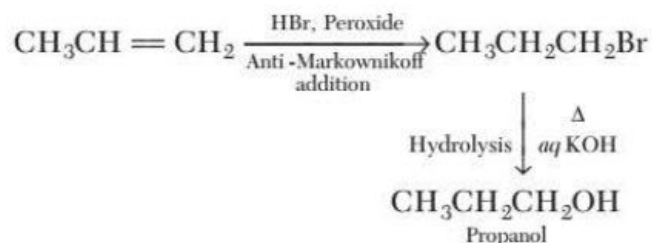

Question 73

Which of the following is a false statement?

Options:

- A. Methoxymethane has higher boiling point than ethanol.
B. Alcohols are more soluble in water than hydrocarbons of comparable molecular mass.
C. ortho- and para-nitrophenols are more acidic than phenols.
D. Phenol is more acidic than alcohol.

Answer: A

Solution:

Solution:

Ethanol undergoes intermolecular H-bonding due to the presence of a hydrogen attached to an electronegative oxygen atom. Hence, ethanol exists as associated molecules and a large amount of energy is required to break these H-bonds. Therefore, the boiling point of ethanol is higher than that of methoxy methane which does not form H-bonds.

Question 74

Which of the following molecules does not exhibit dipole moment?

- (i) CCl_4
(ii) CO_2
(iii) NH_3
(iv) CHCl_3
(v) H_2O

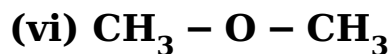

Options:

- A. (ii), (v), (iv)
- B. (i), (iii), (vi)
- C. (i), (ii)
- D. (iii), (iv), (vi)

Answer: C

Solution:

Solution:

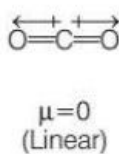
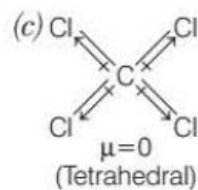

Dipole moments cancel out each other in CCl_4 and CO_2 resulting in net dipole moment as zero because these are symmetrical structures.

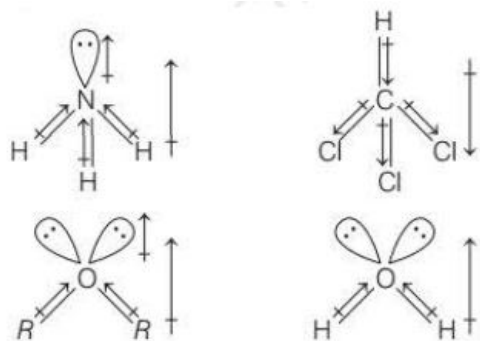

Question 75

Which of the following is highly basic?

Options:

- A. Diphenylamine
- B. Benzylamine
- C. Aniline
- D. Triphenylamine

Answer: B

Solution:

Solution:

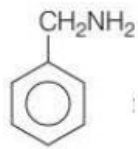

i.e. benzylamine is the most basic among other given options because lone pairs of N are available for donation. whereas lone pair of N in aniline, diphenylamine and triphenyl amine are delocalised over the benzene ring, hence are not available for donation, making them weaker bases.

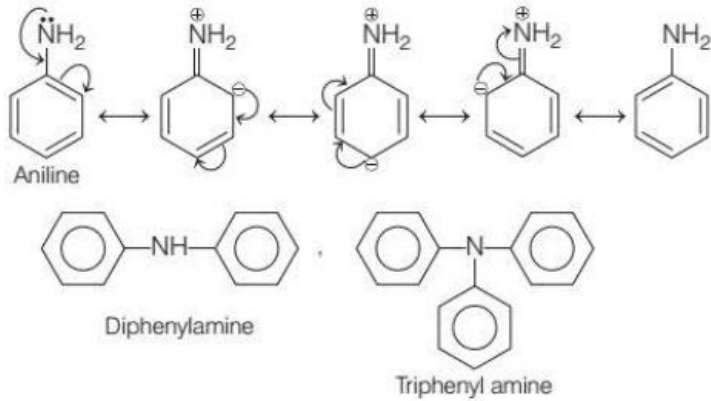

Question 76

The relation between work done in reversible and irreversible process is

Options:

- A. $W_{\text{irr}} > W_{\text{rev}}$
- B. $W_{\text{irr}} < W_{\text{rev}}$
- C. $W_{\text{irr}} = W_{\text{rev}}$
- D. $W_{\text{irr}} \neq W_{\text{rev}}$

Answer: B

Solution:

Solution:

All natural processes are generally irreversible and net work done in an irreversible process is somewhat less than in reversible process.

Question 77

What is the function platelets?

Options:

- A. It binds to oxygen
- B. It binds to carbon dioxide
- C. It forms cyanide in body

D. It leads to coagulation of blood

Answer: D

Solution:

Solution:

Platelets are pieces of very large cells in bone marrow. They help in forming blood clots to stop bleeding and wounds heal.

Question 78

The monosaccharides of maltose is

Options:

A. α -D-glucose and α -D-glucose

B. β -D-glucose and α -D-glucose

C. α -D-glucose and α -D-fructose

D. α -D-glucose and β -D-fructose

Answer: A

Solution:

Solution:

Hydrolysis of maltose yields two moles of α -D-glucose in which C-1 of one glucose linked to C-4 of another glucose.

Question 79

Which of the following does not affect solubility of a gas in liquid?

Options:

A. Nature of gas and liquid

B. Pressure

C. Concentration

D. Temperature

Answer: C

Solution:

Solution:

The solubility of any gas in a particular liquid is the volume of gas that can be dissolved in unit volume of liquid. It only depend upon pressure, temperature and nature of gas and liquid.

Question 80

Which of the following statement is incorrect for H_2O_2 structure?

Options:

- A. It has an open book structur
- B. Its dihedral angle is 180° .
- C. It O – O bond length is 145.8 and O – H is 98.8 .
- D. Angle between both planes is 90.2° .

Answer: B

Solution:

Solution:

H_2O_2 has open book structure with O – O spins. Its dihedral angle is 111° .

Question 81

A newly prepared radioactive nuclide has a decay constant of 6.93 s^{-1} . What is the half-life of the nuclide?

Options:

- A. 0.1 s
- B. 0.2 s
- C. 0.3 s
- D. 0.4 s

Answer: A

Solution:

Solution:

Radioactive nuclide follow first order kinetics

$$t_{\frac{1}{2}} = \frac{0.693}{\lambda} = \frac{0.693}{6.93} = 0.1 \text{ s}$$

Question 82

Which of the following show both Frenkel and Schottky defect?

Options:

- A. ZnS
- B. AgBr
- C. NaCl
- D. AgCl

Answer: B

Solution:

Solution:

ZnS and AgCl show Frenkel defect. NaCl show Schottky defect but AgBr show both defect.

Question 83

The essential amino acid are

- (i) Leucine
- (ii) Glutamic acid
- (iii) Asparagine
- (iv) Valine

correct option is

Options:

- A. (i), (ii)
- B. (ii), (iii)
- C. (iii), (iv)
- D. (i), (iv)

Answer: D

Solution:

Solution:

The essential amino acids are histidine, isoleucine, leucine, lysine, methionine, phenylalanine, threonine, tryptophan and valine.

Question 84

Increasing order of bond order of oxygen and its ions is

Options:

- A. $O_2 < O_2^+ < O_2^{2-} < O_2^-$
- B. $O_2^- < O_2^{2-} < O_2^+ < O_2$

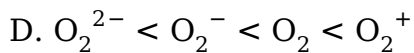
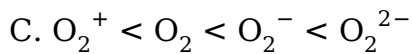

Answer: D

Solution:

Solution:

According to MOT, bond order is given by the formula, $BO = \frac{N_b - N_a}{2}$ where N_a , N_b are the number of electrons in antibonding and bonding molecular orbital respectively.

$$\text{Bond order for } O_2 = \frac{10 - 6}{2} = 2$$

$$O_2^- = \frac{10 - 7}{2} = 1.5$$

$$O_2^+ = \frac{10 - 5}{2} = 2.5$$

$$O_2^{2-} = \frac{10 - 8}{2} = 1$$

Question 85

Minimum number of nodes are present in

Options:

A. 2s

B. 3s

C. 4s

D. 5s

Answer: A

Solution:

Solution:

Total number of nodes is given by $(n - 1)$

$$2s = (2 - 1) = 1$$

$$3s = (3 - 1) = 2$$

$$4s = (4 - 1) = 3$$

$$5s = (5 - 1) = 4$$

Question 86

pH of $10^{-3}M$ solution of KOH is

Options:

A. 7.01

B. 2

C. 11

D. 9

Answer: C

Solution:

Solution:

As KOH is a base.

$$\text{pOH} = -\log[\text{OH}^-]$$

$$\text{pOH} + -\log[10^{-3}] = 3$$

$$\text{pH} + \text{pOH} = 14$$

$$\text{p}_H = 14 - 3 = 11$$

Question 87

Barbiturates are used to treat

Options:

A. fatigue

B. hallucinations

C. allergies

D. depression

Answer: D

Solution:

Solution:

Barbiturates are the depressants drug used to treat depression.

Question 88

Which of the product is not possible in Wurtz reaction?

Options:

A. Methane

B. Ethane

C. Propane

D. Butane

Answer: A

Solution:

Solution:

Wurtz reaction is kind of reaction in which there is a formation of simple higher alkane from alkyl halides. Minimum two carbon chains should be present to form alkane in this reaction. So, methane cannot be formed.

Question 89

The colour of CrO_4^{2-} changes to $\text{Cr}_2\text{O}_7^{2-}$ is

Options:

- A. yellow to orange
- B. orange to yellow
- C. yellow to blue
- D. orange to blue

Answer: A

Solution:**Solution:**

The CrO_4^{2-} (yellow) exist in acidic medium with $\text{pH} = 6$ and changes to orange in basic medium as $\text{Cr}_2\text{O}_7^{2-}$ with $\text{pH} = 8$

Question 90

On treatment of glucose with bromine water the product formed is

Options:

- A. saccharic acid
- B. gluconic acid
- C. glutamic acid
- D. acetic acid

Answer: B

Solution:**Solution:**

Bromine acts as mild oxidising agent and oxidation of glucose with bromine water form gluconic acid. This show presence of aldehyde group in glucose.

Question 91

Which among the following forms minimum boiling azeotropes?

(i) Heptane + Octane

- (ii) Water + Nitric acid
- (iii) Ethanol + Water
- (iv) Acetone + Carbon dioxide

Options:

- A. (i), (ii), (iv)
- B. (i), (ii) only
- C. (i), (iii), (iv)
- D. (iv) only

Answer: C

Solution:

Solution:

Those azeotropes which boils at a temperature lower than boiling point of each component forms the minimum boiling azeotrope.

e.g. Heptane + octane, ethanol + water, acetone + carbon dioxide

Question 92

Which of the following statement is incorrect about activation energy?
boldsymbol a. Higher the activation energy slower is the rate of reaction.

Options:

- A. Higher the activation energy slower is the rate of reaction.
- B. Catalyst decreases the activation energy.
- C. SI unit of activation energy is $\text{J} / \text{mol} / \text{K}^{-1}$.
- D. Activation energy depends upon the rate of reaction.

Answer: C

Solution:

Solution:

The incorrect statement about activation energy is option (c) because the SI unit of activation energy is J / mol or kJ / mol or kcal / mol .

Question 93

The P – O bond order in PO_4^{3-} is

Options:

- A. 1
- B. 1.5
- C. 1.45
- D. 1.25

Answer: D

Solution:

Solution:

The structure of PO_4^{3-} is

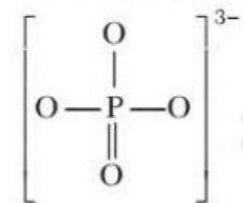

$$\text{Bond order} = \frac{\text{Number of bonds}}{\text{Number of resonating structure}}$$

$$= \frac{5}{4} = 1.25$$

Question 94

O_2^- , F^- , Mg^{2+} , Al^{3+} , O_2 , F_2 . How many of the species given above are isoelectronic?

Options:

- A. 4
- B. 2
- C. 3
- D. 5

Answer: A

Solution:

Solution:

Those species which have same number of electrons are called isoelectronic species.

O_2^- , F^- , Mg^{2+} , Al^{3+} have 10 electrons.

Hence, 4 isoelectronic species are present.

Question 95

How many atoms are present in hcp per unit cell?

Options:

- A. 4
- B. 2
- C. 1
- D. 6

Answer: D

Solution:

Solution:

The hcp (hexagonal close packing) has a coordination number of 12 and contains 6 atoms per unit cell.

Question 96

The equilibrium constant, K_c for $3C_2H_2(g) \rightleftharpoons C_6H_6(g)$ is $4L^2mol^{-2}$. If the equilibrium concentration of benzene is $0.5mol^{-1}$ than what is the value of concentration of ethylene?

Options:

- A. 0.05 mol / L
- B. 0.5 mol / L
- C. 0.25 mol / L
- D. 0.025 mol / L

Answer: B

Solution:

Solution:

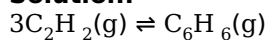

$$K_c = \frac{[C_6H_6]}{[C_2H_2]^3} = \frac{0.5}{[C_2H_2]^3}$$

$$4 = \frac{0.5}{[C_2H_2]^3}$$

$$[C_2H_2] = \sqrt[3]{\frac{0.5}{4}} = \frac{1}{2}$$

$$[C_2H_2] = 0.5 \text{ mol L}^{-1}$$

Therefore, the concentration of ethylene is 0.5 mol / L.

Question 97

Which of the following artificial sweeteners can be used in soft drinks only?

Options:

- A. Alitame
- B. Aspartame
- C. Sucralose
- D. Saccharine

Answer: B

Solution:

Solution:

Aspartame is used in soft drinks. It is an artificial sweetening agent which is unstable at higher temperatures. It is a compound formed from aspartic acid and phenyl alanine. It is 100 times as sweet as cane sugar.

Question 98

Identify the product formed in the given reaction.

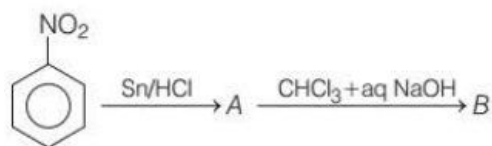

Options:

A.

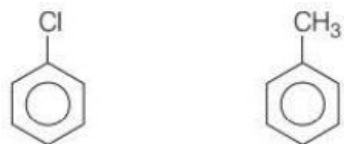

B.



C.



D.



Answer: B

Solution:

Solution:

Complete reaction of the given reaction is as follows.

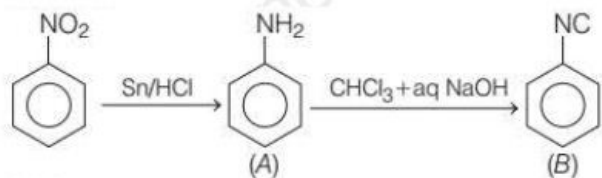

Question 99

Which of the following gas readily de-colourises the acidified KMnO_4 solution?

Options:

- A. CO_2
- B. SO_2
- C. P_2O_5
- D. NO_2

Answer: B

Solution:**Solution:**

Sulphur dioxide gas readily decolourises the purple colour of acidified KMnO_4 solution. In this case, KMnO_4 acts as an oxidising agent and sulphur dioxide gas acts as a reducing agent.

Question 100

Which of the following gas readily de-colourises the acidified KMnO_4 solution?

Options:

- A. CO_2
- B. SO_2
- C. P_2O_5
- D. NO_2

Answer: B

Solution:**Solution:**

Let, the rate of diffusion of gas X, $r_1 = b$. Therefore, rate of diffusion of methane, $r_2 = 2b$

According to Graham's law of diffusion,

$$\left(\frac{r_1}{r_2}\right) = \left(\sqrt{\frac{M_2}{M_1}}\right)$$

$M_1 =$ molecular mass of gas X

$M_2 =$ molecular mass of methane = 16g

$$\therefore \frac{b}{2b} = \sqrt{\frac{16}{M_2}}$$

$$\Rightarrow \left(\frac{1}{4}\right) = \frac{16}{M_2}$$

$$\Rightarrow M_2 = 64g$$

Therefore, molecular mass of X is 64g.

Question 101

Which of the following is used to prepare the inner lining of a blast furnace?

Options:

- A. Graphite bricks
- B. Silica bricks
- C. Fire clay bricks
- D. basic bricks

Answer: C

Solution:

Solution:

Fire clay bricks is used to prepare the inner lining of a blast furnace. It is highly refractory in nature and does not melt, even at huge temperature. Its main components are silica and alumina.

Question 102

What will be the emf of the following cell at 25°C ?

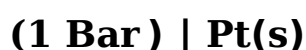
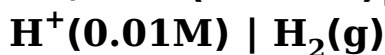
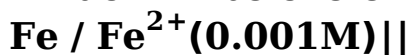

$$E_{(\text{Fe}^{2+} / \text{Fe})}^{\circ} = -0.44\text{V}; E_{(\text{H}^+ / \text{H}_2)}^{\circ} = 0.00\text{V}$$

Options:

- A. 0.44V
- B. -0.44V
- C. 0.41V
- D. -0.41V

Answer: C

Solution:

Solution:

For the given cell representation, the cell reaction will be,

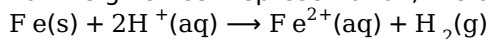

The standard emf of the cell will be,

$$E^{\circ}_{cell} = E^{\circ}_{\frac{H^+}{H_2}} - E^{\circ}_{\frac{Fe^{2+}}{Fe}}$$

$$= 0 - (-0.44) = 0.44V$$

The Nernst equation for the cell reaction at 25°C,

$$E_{cell} = E^{\circ}_{cell} - \frac{0.0591}{n} \log \frac{[Fe^{2+}]}{[H^+]^2}$$

$$= 0.44 - \frac{0.0591}{2} \log \frac{[0.001]}{[0.01]^2}$$

$$= 0.44 - 0.02955(\log 10)$$

$$= 0.44 - 0.02955(1)$$

$$= 0.41045V = 0.41V$$

Question 103

Which of the following vitamin is responsible for beri-beri disease?

Options:

A. A

B. B₁

C. K

D. D

Answer: B

Solution:

Solution:

Beri-beri disease is caused by the deficiency of vitamin B₁.

Question 104

Find the product formed for the given reaction.



Options:

A.

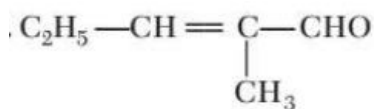

B.



C.

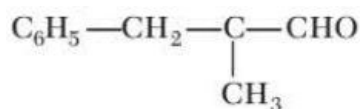

D.

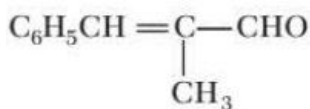

Answer: D

Solution:

Solution:

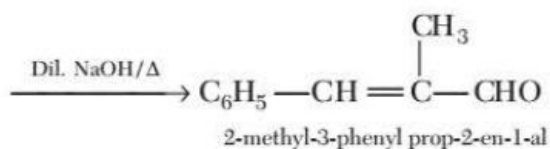
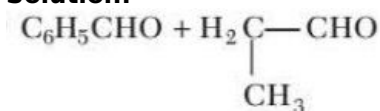

Question 105

In which of the following changes, entropy decreases?

Options:

- A. Rusting of iron
- B. Melting of ice
- C. Vaporisation of camphor
- D. Crystallisation of sucrose from solution

Answer: D

Solution:

Solution:

Among the given options, entropy decreases during the crystallisation of sucrose from solution. It is because entropy is a measure of randomness and during the process of crystallisation liquid state changes into solid state. Hence, entropy decreases.

Question 106

Which of the following is added to soaps to impart antiseptic properties?

Options:

- A. Iodine
- B. Furacine
- C. Bithional
- D. Terpeneol

Answer: C

Solution:

Solution:

Bithional is an antiseptic which is widely used in medicinal soaps, so that soaps can impart antiseptic properties.

Question 107

Which among the following will not liberate nitrogen on reaction with nitrous acid?

Options:

- A. dimethylamine
- B. 2-aminopropane
- C. ethylamine
- D. methylamine

Answer: A

Solution:

Solution:

Only aliphatic primary amines can react with nitrous acid to produce alcohol, water and nitrogen gas.

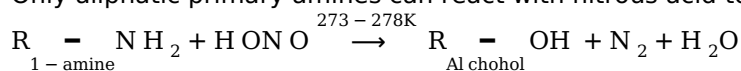

So, dimethylamine which is a secondary amine cannot liberate N_2 with HONO .

Question 108

- The complex which does not show optical isomerism is

Options:

- A. cis - $[\text{Co}(\text{en})_2\text{Cl}_2]\text{Cl}$

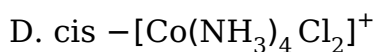
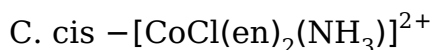

Answer: D

Solution:

Solution:

Octahedral complex of general formula

$[\text{M}(\text{AA})_2\text{a}_2]^{n\pm}$ shows optical isomerism. cis-

$[\text{Co}(\text{N H}_3)_4\text{Cl}_2]^+$ does not show optical isomerism due to symmetry, while other three complexes show optical isomerism.

Question 109

. What will be the density of N_2 gas at 230°C and 3 atm pressure?

($R = 0.082\text{L atm K}^{-1}\text{ mol}^{-1}$)

Options:

A. 3.41g / mL

B. 2.03g / mL

C. 4.30g / mL

D. 0.27g / mL

Answer: B

Solution:

Solution:

We know, $pV = nRT$

or $pV = \frac{W}{M}RT$ [Here, $n = \frac{\text{Weight of gas taken}(W)}{\text{Molar mass of gas}(M)}$]

or $p = \frac{W}{VM}RT$

or $p = \frac{dRT}{M}$ [Here, density(d) = $\frac{\text{Mass}}{\text{Volume}}$]

$\therefore d = \frac{pM}{RT} = \frac{3 \times 28}{0.082 \times 503} = \frac{84}{41.246} = 2.03\text{g / mL}$

Question 110

The solution which have lowest freezing point is

Options:

A. 0.2MK₂SO₄

B. 0.2M KCl

C. 0.2M NaNO₃

D. 0.2M MgSO₄

Answer: A

Solution:

Solution:

Higher the value of van't Hoff factor (i), higher will be depression in freezing point and lower will be the freezing point of solution.

So, 'i' value, 0.2M K₂SO₄ = 3

0.2M KCl = 2

0.2M NaNO₃ = 2

0.2M MgSO₄ = 2

Hence, 0.2M K₂SO₄ will have lowest freezing point.

Question 111

Calculate the molar conductance of 0.025M aqueous solution of calcium chloride at 25°C. The specific conductance of calcium chloride is $12.04 \times 10^{-2} \text{Sm}^{-1}$

Options:

A. $4.816 \times 10^{-5} \text{Sm}^2 \text{mol}^{-1}$

B. $3.816 \times 10^{-5} \text{Sm}^2 \text{mol}^{-1}$

C. $381.6 \times 10^{-5} \text{Sm}^2 \text{mol}^{-1}$

D. $481.6 \times 10^{-5} \text{Sm}^2 \text{mol}^{-1}$

Answer: D

Solution:

Solution:

Molar conductance = λ_m

$$\lambda_m = \frac{\kappa \times 10^{-3}}{M} \text{mol}^{-1} \text{m}^3$$

$$= \frac{(12.04 \times 10^{-2} \text{Sm}^{-1}) \times 10^{-3} (\text{mol}^{-1} \text{m}^3)}{0.025}$$

$$= 481.6 \times 10^{-5} \text{Sm}^2 \text{mol}^{-1}$$

Question 112

For the reaction $2\text{N}_2\text{O}_5 \rightarrow 4\text{NO}_2 + \text{O}_2$.

If initial pressure is 100 atm and rate constant k is $3.38 \times 10^{-5} \text{s}^{-1}$. After 20 min the final pressure of N_2O_5 will be

Options:

- A. 96 atm
- B. 50 atm
- C. 70 atm
- D. 60 atm

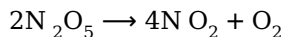
Answer: A**Solution:****Solution:**

$$\left[\begin{array}{cccc} \text{I n i t i a l} & p_0 & 0 & 0 \\ \text{F i n a l} & p_0 - 2x & 4x & x \end{array} \right]$$

$$k = \frac{2.303}{t} \log \frac{p_0}{p_t}$$

$$3.38 \times 10^{-5} = \frac{2.303}{20 \times 60} \log \frac{100}{p_t}$$

$$0.0176 = \log \frac{100}{p_t}$$

$$p_t = 96 \text{ atm}$$

Question 113

The difference between heat capacity at constant pressure and heat capacity at constant volume is

Options:

- A. R
- B. $\frac{R}{T}$
- C. $\frac{R}{V}$
- D. 1

Answer: A**Solution:****Solution:**

Heat capacity at constant

Pressure = C_p

Heat capacity at constant volume = C_v

As we all know,

$$C_p - C_v = R$$

Question 114

Which of the following gas is responsible for acid rain?

Options:

- A. Sulphur dioxide and nitrous oxide
- B. Sulphur dioxide and carbon monoxide
- C. Sulphur dioxide and carbon dioxide
- D. Sulphur dioxide and nitrogen oxide

Answer: D

Solution:

Solution:

Among the given options, sulphur dioxide and nitrogen oxides are responsible for acid rain. It is because sulphur dioxide and nitrogen oxide reacts with water to give sulphuric acid and nitric acid respectively.

Question 115

Which of the following compound does not exists?

Options:

- A. NCl_3
- B. NCl_5
- C. SbCl_3
- D. NI_3

Answer: B

Solution:

Solution:

N belongs to second period as it has no d-orbital. So, five pairs of bonding electrons around nitrogen is not possible. As a result NCl_5 does not exist.

Question 116

The major product in the given reaction is

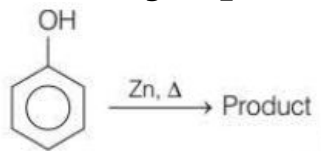

Options:

- A. toluene
- B. p-methyl toluene
- C. benzene
- D. o-methyl benzene

Answer: C

Solution:**Solution:**

Phenol is converted to benzene on heating with zinc dust.

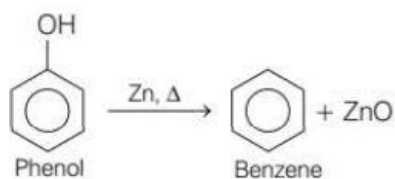

Hence, benzene is the major product.

Question 117

The spectrum of He^+ is similar to

Options:

- A. H
- B. Li^+
- C. Na
- D. He^+

Answer: A

Solution:**Solution:**

As H^+ and He^+ contain same number of electron. So, they show same type of spectra.

Question 118

The Paschen series of hydrogen spectrum lies in which region?

Options:

- A. UV region
- B. IR region

C. Visible region

D. Microwave region

Answer: B

Solution:

Solution:

Paschen series of atomic spectrum of hydrogen gas lies in infrared region.

Question 119

The oxidation state of nickel in $[\text{Ni}(\text{CO})_4]$ is

Options:

A. 1

B. 2

C. 3

D. 0

Answer: D

Solution:

Solution:

$[\text{Ni}(\text{CO})_4]$

$x + 4(0) = 0$

$x = 0$

Therefore, oxidation state of Ni is zero.

Question 120

The correct condition for physical adsorption is

Options:

A. High T and high p

B. High T and low p

C. Low T and high p

D. T and p do not affect

Answer: C

Solution:

Solution:

Low temperature and high pressure favours physical adsorption because van der Waals' forces of attraction will increase.

Question 121

The value of $3^{\log_4 5} - 5^{\log_4 3}$ is

Options:

- A. 0
- B. 1
- C. 2
- D. 4

Answer: A

Solution:**Solution:**

We have,
 $3^{\log_4 5} - 5^{\log_4 3} = 3^{\log_4 5} - 3^{\log_4 5} = 0$

Question 122

If the tangent to the curve $xy + ax + by = 0$ at $(1, 1)$ is inclined at angle $\tan^{-1} 2$ with X-axis, then

Options:

- A. $a = 1, b = 2$
- B. $a = 1, b = -2$
- C. $a = -1, b = 2$
- D. $a = -1, b = -2$

Answer: B

Solution:**Solution:**

Given curve, $xy + ax + by = 0$ (i)

$(1, 1)$ lie on curve (i)

$\therefore 1 + a + b = 0$ (ii)

From Eq. (i)

$$x \frac{dy}{dx} + y \cdot 1 + a + b \frac{dy}{dx} = 0$$

$$\Rightarrow \frac{dy}{dx} = \frac{-(a+y)}{(b+x)}$$

$$\therefore \left(\frac{dy}{dx} \right)_{(1,1)} = \frac{-(a+1)}{b+1} = 2 (\because m = \tan\theta)$$

$$\therefore -\frac{(-b)}{b+1} = 2 \text{ [from Eq.(ii)]}$$

$$\Rightarrow b = 2b + 2$$

$$\therefore b = -2$$

From Eq.(ii), $a = 1$

Hence, $a = 1, b = -2$

Question 123

If $\lim_{x \rightarrow 0} \frac{(1+a^3) + 8e^{1/x}}{1 + (1-b^3)e^{1/x}} = 2$, then

Options:

A. $a = 1, b = 2$

B. $a = 1, b = -3^{1/3}$

C. $a = 2, b = 3^{1/3}$

D. None of these

Answer: B

Solution:

Solution:

Divide and multiply by $e^{\frac{1}{x}}$, then

$$\lim_{x \rightarrow 0} \frac{(1+a^3) + 8e^{1/x}}{1 + (1-b^3)e^{1/x}} = 2$$

$$\Rightarrow \frac{0+8}{0+1-b^3} = 2 \Rightarrow 1-b^3 = 4 \Rightarrow b^3 = -3$$

$$\Rightarrow b = -3^{1/3}$$

Then, $a \in \mathbb{R}$.

Question 124

If two circles $(x-1)^2 + (y-3)^2 = r^2$ and $x^2 + y^2 - 8x + 2y + 8 = 0$

Options:

A. $2 < r < 8$

B. $r < 2$

C. $r = 2$

D. $r > 2$

Answer: A

Solution:

Solution:

Centre and radii of the given circles are $C_1(1, 3)$,

$r_1 = r$ and $C_2(4, -1)$, $r_2 = 3$ respectively. Since, circles intersect in two distinct points, then

$$|r_1 - r_2| < C_1C_2 < r_1 + r_2$$

$$\Rightarrow |r - 3| < 5 < r + 3 \dots\dots\dots(i)$$

From last two relations, $r > 2$

From first two relations,

$$|r - 3| < 5$$

$$\Rightarrow -5 < r - 3 < 5$$

$$\Rightarrow -2 < r < 8 \dots\dots\dots(ii)$$

\therefore From Eq.(i) and Eq.(ii), we get

$$2 < r < 8$$

Question 125

The approximate value of $(0.007)^{1/3}$ is

Options:

A. $\frac{21}{120}$

B. $\frac{23}{120}$

C. $\frac{29}{120}$

D. $\frac{31}{120}$

Answer: B

Solution:

Solution:

$$\text{Let } \delta(x) = x^{\frac{1}{3}}$$

$$\text{Now, } f(x + \delta x) - f(x) = f'(x)\delta(x) = \frac{\delta x}{3x^{\frac{2}{3}}}$$

We may write $0.007 = 0.008 - 0.001$

Taking $x = 0.008$ and $\delta x = -0.001$

We have,

$$f(0.007) - f(0.008) = \frac{-0.001}{3(0.008)^{\frac{2}{3}}}$$

$$\text{or } f(0.007) - f(0.008) = \frac{-1}{120}$$

$$\therefore f(0.007) = f(0.008) - \frac{1}{120} = 0.2 - \frac{1}{120}$$

$$\Rightarrow (0.007)^{\frac{1}{3}} = \frac{23}{120}$$

Question 126

The circle $x^2 + y^2 + 4x - 7y + 12 = 0$ cuts an intercept on Y-axis of length

Options:

- A. 3
- B. 4
- C. 7
- D. 1

Answer: D

Solution:

Solution:

$$\begin{aligned} \text{Intercept on Y-axis} &= 2\sqrt{f^2 - c} \\ &= 2\sqrt{\frac{49}{4} - 12} = 1 \end{aligned}$$

Question 127

Let $f(x) = a - (x - 3)^{8/9}$, then maxima of $f(x)$ is

Options:

- A. 3
- B. $a - 3$
- C. a
- D. None

Answer: C

Solution:

Solution:

$$\begin{aligned} \therefore f(x) &= a - (x - 3)^{\frac{8}{9}} \\ \therefore f'(x) &= 0 - \frac{8}{9}(x - 3)^{-\frac{1}{9}} \end{aligned}$$

At $x = 3$, $f'(x)$ is not defined.
Hence, $x = 3$ is the point of extremum.
Hence, maximum value of $f(x) = a$ at $x = 3$

Question 128

.If the derivative of the function $f(x) = \begin{cases} bx^2 + ax + 4; & x \geq -1 \\ ax^2 + b; & x < -1 \end{cases}$ is everywhere continuous, then

Options:

A. $a = 2, b = 3$

B. $a = 3, b = 2$

C. $a = -2, b = -3$

D. $a = -3, b = -2$

Answer: A

Solution:

Solution:

We have,

$$f(x) = \begin{cases} ax^2 + b & x < -1 \\ bx^2 + ax + 4 & x \geq -1 \end{cases}$$

$$\therefore f'(x) = \begin{cases} 2ax & x < -1 \\ 2bx + a & x \geq -1 \end{cases}$$

$\therefore f(x)$ is differentiable at $x = -1$

\therefore It is continuous at $x = -1$ and hence

$$\lim_{(x \rightarrow -1^-)} f(x) = \lim_{(x \rightarrow -1^+)} f(x)$$

$$\Rightarrow a + b = b - a + 4$$

$$\Rightarrow a = 2$$

$$\text{and also, } \lim_{(x \rightarrow -1^-)} f'(x) = \lim_{(x \rightarrow -1^+)} f'(x)$$

$$\Rightarrow -2a = -2b + a$$

$$\Rightarrow 3a = 2b \Rightarrow b = 3 (\because a = 2)$$

Hence, $a = 2, b = 3$

Question 129

If $\lim_{x \rightarrow \infty} \left(1 + \frac{a}{x} + \frac{b}{x^2} \right)^{2x} = e^2$, then

Options:

A. $a = 1, b = 2$

B. $a = 2, b = 1$

C. $a = 1, b \in \mathbb{R}$

D. None of these

Answer: C

Solution:

Solution:

$$\lim_{x \rightarrow \infty} \left(1 + \frac{a}{x} + \frac{b}{x^2} \right)^{2x} = e^2$$

$$\Rightarrow \lim_{x \rightarrow \infty} \left(1 + \frac{(ax + b)}{x^2} \right)^2 x = e^2 \dots\dots\dots(i)$$

$\lim_{x \rightarrow \infty} \frac{ax + b}{x^2}$ must be equal to zero.

$$\Rightarrow \lim_{x \rightarrow \infty} \frac{ax + b}{x^2} = 0$$

$$\Rightarrow \lim_{x \rightarrow \infty} \left(\frac{a}{x} + \frac{b}{x^2} \right) = 0$$

$\therefore a$ and $b \in \mathbb{R}$

From Eq. (i), $\lim_{e^{x \rightarrow \infty}} \left(1 + \frac{ax + b}{x^2} - 1 \right) 2x = e^2$

$$\Rightarrow \lim_{e^{x \rightarrow \infty}} \frac{2(ax + b)}{x} = e^2$$

$$\therefore e^{2a} = e^2$$

$$\Rightarrow a = 1 \text{ and } b \in \mathbb{R}$$

Question 130

$S \equiv x^2 + y^2 + 2x + 3y + 1 = 0$ and

$S' \equiv x^2 + y^2 + 4x + 3y + 2 = 0$ are two circles.

The point $(-3, -2)$ lies

Options:

A. inside S' only

B. inside S only

C. inside S and S'

D. outside S and S'

Answer: A

Solution:

Solution:

$$S(-3, -2) = 9 + 4 - 6 - 6 + 1 = 2 > 0$$

$\therefore (-3, -2)$ outside of S

$$\text{and } S'(-3, -2) = 9 + 4 - 12 - 6 + 2 = -3 < 0$$

$\therefore (-3, -2)$ inside of S' .

Question 131

The probability of choosing randomly a number c from the set

$\{1, 2, 3, \dots, 9\}$ such that the quadratic equation $x^2 + 4x + c = 0$ has real roots, is

Options:

A. $\frac{1}{9}$

B. $\frac{2}{9}$

C. $\frac{3}{9}$

D. $\frac{4}{9}$

Answer: D

Solution:

Solution:

$$x^2 + 4x + c = 0$$

For real roots, $D = b^2 - 4ac \geq 0$

$$16 - 4c \geq 0$$

So, $c = 1, 2, 3, 4$ will satisfy the above inequality.

$$\therefore \text{Required probability} = \frac{4}{9}$$

Question 132

Shade the feasible region for the inequations $6x + 4y \leq 120$, $3x + 10y \leq 180$, $x, y \geq 0$ in a rough figure.

Options:

A.

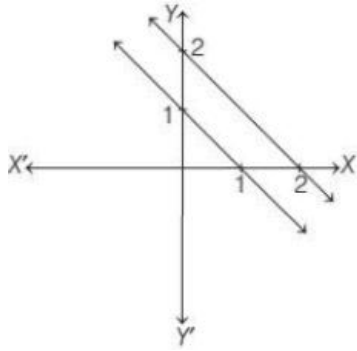

B.

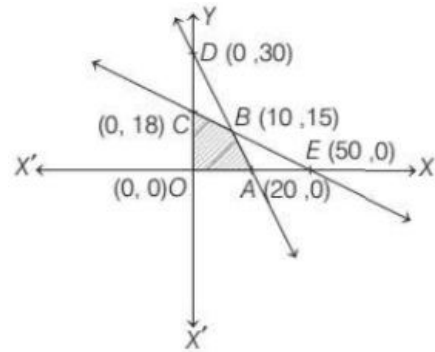

C.

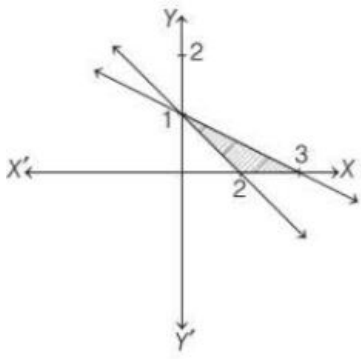

D.

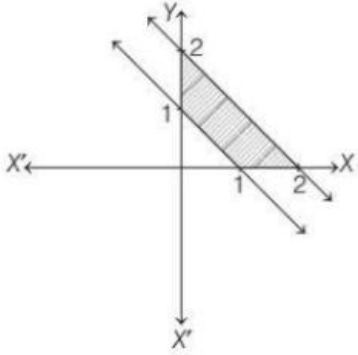

Answer: B

Solution:

Solution:

Given constraints are
 $6x + 4y \leq 120$
 $3x + 10y \leq 180, x, y > 0$

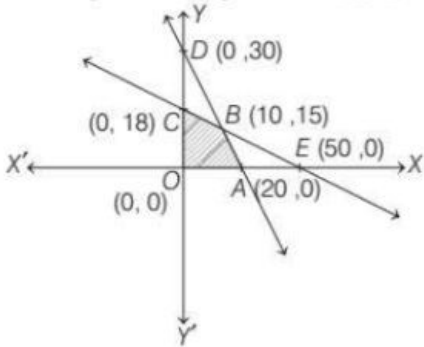

Here, OABCO is the required feasible region whose corner points are O, A, B and C.

Question 133

The maximum of Z is where, $Z = 4x + 2y$ subject to constraints $4x + 2y \geq 46$, $x + 3y \leq 24$ and $x, y \geq 0$ is

Options:

- A. 46
- B. 96
- C. 52

D. None of these

Answer: B

Solution:

Solution:

Feasible region ABCD and $Z = 4x + 2y$

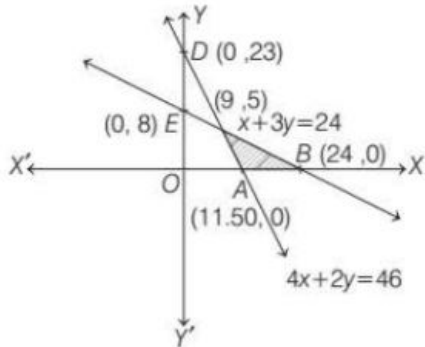

At point C(9, 5), $Z = 4 \times 9 + 2 \times 5 = 46$

At point A(11.5, 0) $Z = 4 \times 11.5 + 2 \times 0 = 46$

At point B(24, 0), $Z = 4 \times 24 + 0 = 26$

Hence, maximum value of Z is 96.

Question 134

If for any 2×2 square matrix A , $A(\text{adj } A) = \begin{bmatrix} 8 & 0 \\ 0 & 8 \end{bmatrix}$, then find the value of $\det(A)$.

Options:

A. 6

B. 7

C. 8

D. 5

Answer: C

Solution:

Solution:

$$\text{Given, } A(\text{adj } A) = \begin{bmatrix} 8 & 0 \\ 0 & 8 \end{bmatrix}$$

By using property $A(\text{adj } A) = |A| I_n$

$$\Rightarrow |A| I_n = \begin{bmatrix} 8 & 0 \\ 0 & 8 \end{bmatrix}$$

$$\Rightarrow |A| I_n = 8 \begin{bmatrix} 1 & 0 \\ 0 & 1 \end{bmatrix} \Rightarrow |A| = 8$$

Question 135

If $A = \begin{bmatrix} a & 0 & 0 \\ 0 & a & 0 \\ 0 & 0 & a \end{bmatrix}$, then $|A| \operatorname{adj} A$ is equal to

Options:

- A. a^{3n}
- B. a^{-3n}
- C. $-a^{3n}$
- D. $2a^{3n}$

Answer: A

Solution:

Solution:

Given, $A = \begin{bmatrix} a & 0 & 0 \\ 0 & a & 0 \\ 0 & 0 & a \end{bmatrix}$

Now, $|A| = a^3$

$\therefore |A| \operatorname{adj} A = |A| |A|^{n-1} = (a^3)^n = a^{3n}$

Question 136

If $A = \begin{bmatrix} 2-k & 2 \\ 1 & 3-k \end{bmatrix}$ is a singular matrix, then the value of $5k - k^2$ is

Options:

- A. 0
- B. 6
- C. -6
- D. 4

Answer: D

Solution:

Solution:

Given, $A = \begin{bmatrix} 2-k & 2 \\ 1 & 3-k \end{bmatrix}$

Since, the Matrix A is singular

$$\therefore |A| = 0$$

$$\Rightarrow A = \begin{bmatrix} 2-k & 2 \\ 1 & 3-k \end{bmatrix} = 0$$

$$\Rightarrow (2-k)(3-k) - 2 = 0$$

$$\Rightarrow 6 - 5k + k^2 - 2 = 0$$

$$\Rightarrow 4 - 5k + k^2 = 0$$

$$\Rightarrow 5k - k^2 = 4$$

Question 137

If θ be the angle between the vectors $\mathbf{a} = 2\hat{i} + 2\hat{j} - \hat{k}$ and $\mathbf{b} = 6\hat{i} - 3\hat{j} + 2\hat{k}$, then

Options:

A. $\cos \theta = \frac{4}{21}$

B. $\cos \theta = \frac{3}{19}$

C. $\cos \theta = \frac{2}{19}$

D. $\cos \theta = \frac{5}{21}$

Answer: A

Solution:

Solution:

$$\begin{aligned} \cos \theta &= \frac{\mathbf{a} \cdot \mathbf{b}}{|\mathbf{a}| |\mathbf{b}|} \\ &= \frac{(2\hat{i} + 2\hat{j} - \hat{k}) \cdot (6\hat{i} - 3\hat{j} + 2\hat{k})}{\sqrt{2^2 + 2^2 + (-3)^2} \sqrt{6^2 + (-3)^2 + 2^2}} \\ &= \frac{12 - 6 - 2}{\sqrt{4 + 4 + 9} \sqrt{36 + 9 + 4}} = \frac{4}{21} \end{aligned}$$

Question 138

If x , y and z are non-zero real numbers and $\mathbf{a} = x\hat{i} + 2\hat{j}$, $\mathbf{b} = y\hat{j} + 3\hat{k}$ and $\mathbf{c} = x\hat{i} + y\hat{j} + z\hat{k}$ are such that $\mathbf{a} \times \mathbf{b} = z\hat{i} - 3\hat{j} + \hat{k}$, then $[abc]$ is equal to

Options:

A. 3

B. 10

C. 9

D. 6

Answer: C

Solution:

Solution:

Given; $a = x\hat{i} + 2\hat{j}$, $b = y\hat{j} + 3\hat{k}$ and $c = x\hat{i} + y\hat{j} + z\hat{k}$

$$\text{Now, } a \times b = \begin{vmatrix} \hat{i} & \hat{j} & \hat{k} \\ x & 2 & 0 \\ 0 & y & 3 \end{vmatrix}$$

$$= \hat{i}(6 - 0) - \hat{j}(3x - 0) + \hat{k}(xy - 0)$$

$$= 6\hat{i} - 3x\hat{j} + xy\hat{k}$$

$$= 6\hat{i} - 3x\hat{j} + xy\hat{k} = z\hat{i} - 3\hat{j} + \hat{k}$$

On equating the coefficients of \hat{i} , \hat{j} and \hat{k} , we get

$$z = 6, x = 1 \text{ and } xy = 1$$

$$\therefore xy = 1, y = 1$$

$$\Rightarrow a = \hat{i} + 2\hat{j}, b = \hat{j} + 3\hat{k}$$

$$\text{and } c = \hat{i} + \hat{j} + 6\hat{k}$$

$$\therefore [abc] = \begin{vmatrix} 1 & 2 & 0 \\ 0 & 1 & 3 \\ 1 & 1 & 6 \end{vmatrix}$$

$$[abc] = 1(6 - 3) - 2(0 - 3) + 0 = 3 + 6 = 9$$

Question 139

Maximum value of $z = 12x + 3y$, subject to constraints $x \geq 0$, $y \geq 0$, $x + y \leq 5$ and $3x + y \leq 9$ is

Options:

- A. 15
- B. 36
- C. 60
- D. 40

Answer: B

Solution:

Solution:

Given, constraints are $x \geq 0$, $y \geq 0$, $x + y \leq 5$ and $3x + y \leq 9$ and $z = 12x + 3y$

Here, feasible region is OABCO.

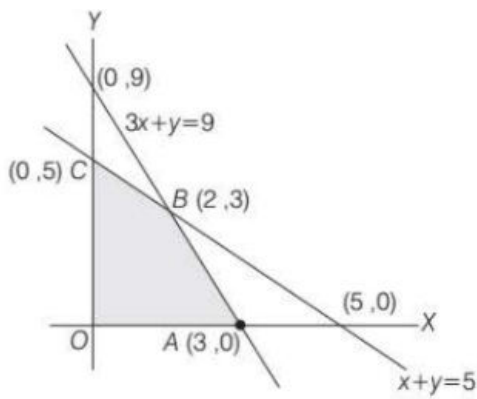

At point $O(0, 0)$, $z = 12(0) + 3(0) = 0$
 At point $A(3, 0)$, $z = 12(3) + 3(0) = 36$
 At point $B(2, 3)$, $z = 12(2) + 3(3) = 33$
 At point $C(0, 5)$, $z = 12(0) + 3(5) = 15$
 Hence, maximum value of z is 36.

Question 140

If $\mathbf{p} = \hat{i} + \hat{j}$, $\mathbf{q} = 4\hat{k} - \hat{j}$ and $\mathbf{r} = \hat{i} + \hat{k}$, then the unit vector in the direction of $3\mathbf{p} + \mathbf{q} - 2\mathbf{r}$ is

Options:

A. $\frac{1}{3}(\hat{i} + 2\hat{j} + 2\hat{k})$

B. $\frac{1}{3}(\hat{i} - 2\hat{j} - 2\hat{k})$

C. $\frac{1}{3}(\hat{i} - 2\hat{j} + 2\hat{k})$

D. $\hat{i} + 2\hat{j} + 2\hat{k}$

Answer: A

Solution:

Solution:

$$\begin{aligned} 3\mathbf{p} + \mathbf{q} - 2\mathbf{r} &= 2(\hat{i} + \hat{j}) + (4\hat{k} - \hat{j}) - 2(\hat{i} + \hat{k}) \\ &= \hat{i} + 2\hat{j} + 2\hat{k} \end{aligned}$$

\therefore Unit vector in the direction of

$$3\mathbf{p} + \mathbf{q} - 2\mathbf{r} = \frac{1}{3}(\hat{i} + 2\hat{j} + 2\hat{k})$$

Question 141

The line $\frac{x-3}{4} = \frac{y-4}{5} = \frac{z-5}{6}$ is parallel to the plane

Options:

A. $3x + 4y + 5z = 7$

B. $x + y + z = 2$

C. $x - 2y + z = 0$

D. $2x + 3y + 4z = 0$

Answer: C

Solution:

Solution:

Given equation of line is

$$\frac{x-3}{4} = \frac{y-4}{5} = \frac{z-5}{6}$$

So, DR's of line are (4, 5, 6)

Since, line is parallel to the plane, therefore the normal to plane is perpendicular to the line.

$$\therefore a_1 a_2 + b_1 b_2 + c_1 c_2 = 0$$

Consider the plane is

$$x - 2y + z = 0$$

Here, $a_2 = 1$, $b_2 = -2$, c_1

So, $a_1 a_2 + b_1 b_2 + c_1 c_2$

$$= (4 \times 1) + (5 \times -2) + (6 \times 1) = 4 - 10 + 6$$

$$= 10 - 10 = 0$$

Hence, required plane is

$$x - 2y + z = 0$$

So, option (c) is correct.

Question 142

$$\int \frac{1}{x\sqrt{ax-x^2}} dx \text{ is}$$

Options:

A. $\frac{-3}{a} \sqrt{\frac{a-x}{x}} + C$

B. $-\frac{2}{a} \sqrt{\frac{x}{a-x}} + C$

C. $\frac{-2}{a} \sqrt{\frac{a-x}{x}} + C$

D. None of these

Answer: C

Solution:

Solution:

$$\text{Let } I = \int \frac{1}{x\sqrt{ax-x^2}} dx$$

$$\text{Putting } x = \frac{a}{t}$$

$$\Rightarrow dx = \frac{-a}{t^2} dt$$

$$\begin{aligned} \therefore I &= \int \frac{1}{\frac{a}{t} \sqrt{\frac{a}{t} \cdot \frac{a}{t} - \frac{a^2}{t^2}}} x - \frac{a}{t^2} dt \\ &= \int \frac{-t}{t^2 \sqrt{\frac{a^2}{t} - \frac{a^2}{t^2}}} dt \\ &= \int \frac{-1}{at \sqrt{\frac{1}{t} - \frac{1}{t^2}}} dt \\ &= \frac{-1}{a} \int \frac{1}{\sqrt{\frac{t^2}{t} - \frac{t^2}{t^2}}} dt \\ &= \frac{-1}{a} \int \frac{1}{\sqrt{t-1}} dt = \frac{-1}{a} \int (t-1)^{-\frac{1}{2}} dt \\ &= \frac{-1}{a} \frac{(t-1)^{\frac{1}{2}}}{\frac{1}{2}} + C = \frac{-2}{a} \left(\frac{a}{x} - 1 \right)^{\frac{1}{2}} + C \\ I &= \frac{-2}{a} \sqrt{\frac{a-x}{x}} + C \end{aligned}$$

Option (c) is correct.

Question 143

3. $\int \frac{3^x}{\sqrt{1-9^x}} dx$ is equal to

Options:

- A. $(\log 3)\sin^{-1}3^x + C$
- B. $\frac{1}{3}\sin^{-1}(3^x) + C$
- C. $\frac{1}{\log 3}\sin^{-1}3^x + C$
- D. $3 \log 3 \sin^{-1}3^x + C$

Answer: C

Solution:

Solution:

$$\text{We have, } I = \int \frac{3^x}{\sqrt{1-9^x}} dx = \int \frac{3^x}{\sqrt{1-(3^x)^2}} dx$$

$$\text{Putting } 3^x = t$$

$$\Rightarrow 3^x \log 3 dx = dt$$

$$\Rightarrow 3^x dx = \frac{1}{\log 3} dt$$

$$\therefore I = \frac{1}{\log 3} \int \frac{1}{\sqrt{1-t^2}} dt$$

$$= \frac{1}{\log 3} \sin^{-1}t + C$$

$$= \frac{1}{\log 3} \sin^{-1}(3^x) + C$$

Option (c) is correct.

Question 144

$$\int_{-\frac{\pi}{2}}^{\frac{\pi}{2}} \cos x \, dx$$

Options:

- A. 2
- B. 0
- C. -1
- D. 5

Answer: A

Solution:

Solution:

Here $f(x) = \cos x$

$f(-x) = \cos(-x) = \cos x = f(x)$

So, f is even function.

$$\therefore \int_{-\frac{\pi}{2}}^{\frac{\pi}{2}} \cos x \, dx = 2 \int_0^{\frac{\pi}{2}} \cos x \, dx$$

[$\because \int_{-a}^a f(x) \, dx = 2 \int_0^a f(x) \, dx$, if f is even]

$$= 2[\sin x]_0^{\frac{\pi}{2}}$$

$$= 2\left[\sin\frac{\pi}{2} - \sin 0\right] = 2[1 - 0] = 2$$

Question 145

The angle between the lines $\frac{x+4}{3} = \frac{y-1}{5} = \frac{z+3}{4}$ and $\frac{x+1}{1} = \frac{y-4}{1} = \frac{z-5}{2}$ is

Options:

- A. 30°
- B. $\cos^{-1}\left(\frac{3}{2\sqrt{2}}\right)$
- C. $\cos^{-1}\left(\frac{8}{5\sqrt{3}}\right)$
- D. None of these

Answer: C

Solution:

Solution:

The angle between two lines

$$\frac{x-x_1}{a_1} = \frac{y-y_1}{b_1} = \frac{z-z_1}{c_1} \text{ and } \frac{x-x_2}{a_2} = \frac{y-y_2}{b_2} = \frac{z-z_2}{c_2}$$

is given by

$$\cos\theta = \frac{a_1a_2 + b_1b_2 + c_1c_2}{\sqrt{a_1^2 + b_1^2 + c_1^2} \sqrt{a_2^2 + b_2^2 + c_2^2}}$$

$$= \frac{3 \times 1 + 5 \times 1 + 4 \times 2}{\sqrt{3^2 + 5^2 + 4^2} \sqrt{1^2 + 1^2 + 2^2}}$$

$$= \frac{16}{\sqrt{50}\sqrt{6}} = \frac{16}{\sqrt{300}}$$

$$\Rightarrow \cos\theta = \frac{16}{10\sqrt{3}}$$

$$\Rightarrow \cos\theta = \frac{8}{5\sqrt{3}}$$

$$\Rightarrow \theta = \cos^{-1}\left(\frac{8}{5\sqrt{3}}\right)$$

So, option (c) is correct.

Question 146

.The point of intersection of the lines $\frac{x-1}{1} = \frac{y-1}{2} = \frac{z-2}{3}$ and $\frac{x-5}{2} = \frac{y-2}{1} = z$ is

Options:

A. (1, -2, 0)

B. (3, 1, 0)

C. (-2, -5, -7)

D. None of these

Answer: D

Solution:

Solution:

Given lines are

$$\frac{x-1}{1} = \frac{y-1}{2} = \frac{z-2}{3} = \lambda \text{ (let)}$$

$$\Rightarrow x = \lambda + 1, y = 2\lambda + 1, z = 3\lambda + 2$$

$$\text{and } \frac{x-5}{2} = \frac{y-2}{1} = z = \mu \text{ (let)}$$

$$\Rightarrow x = 2\mu + 5, y = \mu + 2, z = \mu$$

For point of intersection, we have

$$\lambda + 1 = 2\mu + 5 \text{ and } 2\lambda + 1 = \mu + 2 \text{ and } 3\lambda + 2 = \mu$$

$$\lambda - 2\mu = 4 \dots\dots\dots(i)$$

$$2\lambda - \mu = 1 \dots\dots\dots(ii)$$

$$3\lambda - \mu = -2 \dots\dots\dots(iii)$$

On solving Eqs. (ii) and (iii), we get

$$2\lambda - \mu = 1$$

$$3\lambda - \mu = -2$$

$$- \quad + \quad + \quad \text{So, } \mu = -7$$

$$-\lambda = 3$$

$$\lambda = -3$$

Now, put $\lambda = -3$ and $\mu = -7$ in Eq. (i), we get

$$-3 + 14 = 11 \neq 4$$

Hence, the lines do not intersect.

Hence, option (d) is correct.

Question 147

Five persons A, B, C, D and E are in queue of a shop. The Probability that A and B are always together is

Options:

A. $\frac{2}{5}$

B. $\frac{1}{4}$

C. $\frac{3}{5}$

D. $\frac{2}{3}$

Answer: A

Solution:

Solution:

Given, 5 persons are in a queue of a shop. A and B itself can arrange in two ways therefore number of arrangement for A and B = $2! = 2$ So, probability that A and B are always together

$$= \frac{2! \times 4!}{5!} = \frac{2 \times 4!}{5 \times 4!} = \frac{2}{5}$$

Option (a) is correct.

Question 148

If the probability for A to fail in an examination is 0.2 and that for B is 0.3, then the probability that either A or B fail is

Options:

A. 0.38

B. 0.44

C. 0.50

D. 0.94

Answer: B

Solution:

Solution:

$$P(A) = 0.2, P(B) = 0.3$$

$$\therefore P(A) = 0.8, P(B) = 0.7$$

\therefore Required probability

$$= P(A)P(B) + P(A)P(B) + P(A)P(B)$$

$$= 0.2 \times 0.7 + 0.8 \times 0.3 + 0.2 \times 0.3$$

$$= 0.44$$

Question 149

Three vertices are chosen randomly from the seven vertices of a regular 7-sided polygon. The probability that they form the vertices of an isosceles triangle is

Options:

A. $\frac{1}{7}$

B. $\frac{1}{3}$

C. $\frac{3}{7}$

D. $\frac{3}{5}$

Answer: D

Solution:

Solution:

Number of triangles formed $= {}^7C_3$

Number of isosceles triangles $= 7 \times 3 = 21$

$$\text{So, probability} = \frac{21}{{}^7C_3} = \frac{21}{\frac{7!}{3!(7-3)!}}$$

$$= \frac{21 \times 3! \times 4!}{7 \times 6 \times 5 \times 4!} = \frac{3}{5}$$

Option (d) is correct.

Question 150

If A, B and C are three mutually exclusive and exhaustive events such that $P(A) = 2P(B) = 3P(C)$. What is $P(B)$?

Options:

A. $\frac{6}{11}$

B. $\frac{6}{22}$

C. $\frac{1}{6}$

D. $\frac{1}{3}$

Answer: B

Solution:

Solution:

Given that A, B and C are three mutually exclusive events

$$\Rightarrow P(A) = 2P(B) = 3P(C)$$

$$P(A \cup B \cup C) = P(A) + P(B) + P(C)$$

$$= 2P(B) + P(B) + \frac{2}{3}P(B)$$

$$= \frac{11}{3}P(B)$$

$$\because P(A \cup B \cup C) = 1$$

$$\Rightarrow \frac{11}{3}P(B) = 1 \Rightarrow P(B) = \frac{3}{11}$$

$$\Rightarrow P(B) = \frac{6}{22}$$

Question 151

If $U_{n+1} = 3U_n - 2U_{n-1}$ and $U_0 = 2, U_1 = 3$, then U_n is equal to

Options:

A. $1 - 2^n$

B. $2^n + 1$

C. $2^n - 1$

D. $2^n + 2$

Answer: B

Solution:

Solution:

We know that $U_{n+1} = 3U_n - 2U_{n-1}$ (i)

Step I Given, $U_1 = 3 = 2 + 1 = 2^1 + 1$, which is true for

$n = 1$, put $n = 1$ in Eq.(i),

$$\text{Then } U_{1+1} = 3U_1 - 2U_{1-1}$$

$$\Rightarrow U_2 = 2U_1 - 2U_0$$

$$= 3 \times 3 - 2 \times 2 = 5 = 2^2 + 1$$

Which is true for $n = 2$

\therefore The result are true for $n = 1$ and $n = 2$

Step II Assume it is true for $n = k$, then it is also true for

$$n = k - 1$$

$$\text{Then, } U_k = 2^k + 1 \text{(ii)}$$

$$\text{and } U_{k-1} = 2^{k-1} + 1 \text{(iii)}$$

Step III On putting $n = k$ in Eq.(i), we get

$$U_{k+1} = 3U_k - 2U_{k-1}$$

$$= 3(2^k + 1) - 2(2^{k-1} + 1) \text{ [From Eqs. (ii) and (iii)}$$

$$= 3 \cdot 2^k + 3 - 2 \cdot 2^{k-1} - 2$$

$$= 3 \cdot 2 + 3 - 2^k - 2$$

$$= (3 - 1)2^k + 1$$

$$= 2 \cdot 2^k + 1 = 2^{k+1} + 1$$

This shows that the result is true for $n = k + 1$. Hence by the principle of mathematical induction the result is true for all $n \in \mathbb{N}$.

Question 152

If $4^n + 15n + P$ is divisible by 9 for all $n \in \mathbb{N}$, then the least negative

integral value of P is

Options:

- A. -1
- B. -2
- C. -3
- D. -4

Answer: A

Solution:

Solution:

We have, $P(n) = 4^n + 15n + P$

For $n = 1$, $P(1) = 4 + 15 + p = 19 + p$ is divisible by 9.

Thus, P should be -1 .

Since, $19 - 1 = 18$ is divisible by 9.

Question 153

$(2^{3n} - 1)$ is divisible by

Options:

- A. 6
- B. 7
- C. 8
- D. 9

Answer: B

Solution:

Solution:

For $n = 1$, $2^{3n} - 1$ has value $2^3 - 1 = 7$

For $n = 2$, $2^{3n} - 1$ has value $2^6 - 1 = 63 = 7 \times 9$

which is divisible by 7 not by 6 or 8 or 9.

Hence, option (b) is correct.

Question 154

If $S = \frac{2^2 - 1}{2} + \frac{3^2 - 2}{6} + \frac{4^2 - 3}{12} + \dots$ upto 10 terms, then S is equal to

Options:

- A. $\frac{120}{11}$

B. $\frac{13}{11}$

C. $\frac{110}{11}$

D. $\frac{19}{11}$

Answer: A

Solution:

Solution:

We know, $T_n = \frac{(n+1)^2 - n}{n(n+1)}$

$$= 1 + \left(\frac{1}{n} - \frac{1}{n+1} \right)$$

$$\therefore S_{10} = 10 + \left(1 - \frac{1}{11} \right) = \frac{120}{11}$$

Question 155

$\sum_{n=1}^m n \cdot n!$ is equal to

Options:

A. $m! - 1$

B. $(m-1)! - 1$

C. $(m+1)! - 1$

D. $m!(m-1)!$

Answer: C

Solution:

Solution:

We have, $n \cdot n!$

$$= (n+1-1) \cdot n!$$

$$= (n+1)! - n!$$

$$= V(n) - V(n-1)$$

$$\Rightarrow \sum_{n=1}^m n(n)! = V(m) - V(0) = (m+1)! - 1$$

Question 156

.The first and fifth terms of an A.P. are -14 and 2 respectively and the sum of its n terms is 40 . The value of n is

Options:

A. 8

B. 12

C. 10

D. 13

Answer: C

Solution:

Solution:

We have,

$$a = -14 \text{ and } a + 4d = 2$$

$$\Rightarrow -14 + 4d = 2 \Rightarrow 4d = 14 + 2$$

$$\Rightarrow 4d = 16$$

$$\therefore d = 4$$

$$\text{Now, } S_n = \frac{n}{2}[2a + (n-1)d]$$

$$\Rightarrow 40 = \frac{n}{2}[-28 + (n-1)4]$$

$$\Rightarrow n^2 - 8n - 20 = 0$$

$$\Rightarrow (n-10)(n+2) = 0$$

$$\Rightarrow n = 10$$

Question 157

The solution of the differential equation $\frac{d^2y}{dx^2} = 0$ represents

Options:

A. all circles in a plane

B. all straight lines in a plane

C. all parabolas in a plane

D. all ellipses in a plane

Answer: B

Solution:

Solution:

Given, differential equation is $\frac{d^2y}{dx^2} = 0$

On integrating, we get

$$\frac{dy}{dx} = c, \text{ where } c \text{ is a constant}$$

$$\Rightarrow dy = cd x$$

Again integrating,

$$\Rightarrow \int dy = c \int dx$$

$$\Rightarrow y = cx + d, \text{ where } d \text{ is constant.}$$

\therefore The solution of differential equation represents all straight lines in a plane.

Question 158

The solution of the differential equation $\frac{dy}{dx} + \sqrt{\frac{1-y^2}{1-x^2}} = 0$ is

Options:

- A. $\cos^{-1}x + \cos^{-1}y = c$
- B. $\sin^{-1}x + \sin^{-1}y = c$
- C. $\cosh^{-1}x + \cosh^{-1}y = c$
- D. $\sinh^{-1}x + \sinh^{-1}y = c$

Answer: B

Solution:

Solution:

$$\text{Given, } \frac{dy}{dx} + \frac{\sqrt{1-y^2}}{\sqrt{1-x^2}} = 0$$

$$\Rightarrow \frac{dy}{\sqrt{1-y^2}} + \frac{dx}{\sqrt{1-x^2}} = 0$$

On integrating, we get

$$\Rightarrow \int \frac{dy}{\sqrt{1-y^2}} + \int \frac{dx}{\sqrt{1-x^2}} = 0$$

$$\Rightarrow \sin^{-1}y + \sin^{-1}x = c$$

Question 159

The solution of the differential equation $x \frac{dy}{dx} = \cot y$ is

Options:

- A. $y \cos x = c$
- B. $x \cos y = c$
- C. $\log(x \cos y) = c$
- D. $\log(y \cos x) = c$

Answer: B

Solution:

Solution:

$$\text{Given, } x \frac{dy}{dx} = \cot y$$

$$\Rightarrow \tan y \, dy = \frac{dx}{x}$$

On integrating, we get

$$\Rightarrow \int \tan y \, dy = \int \frac{dx}{x}$$

$$\Rightarrow \log \sec y = \log x + \log c_1$$

$$\Rightarrow \log \sec y = \log x \cdot c_1$$

$$\Rightarrow \sec y = x \cdot c_1$$

$$\Rightarrow x \cos y = c,$$

Where $c = \frac{1}{c_1}$

Question 160

If ${}^n C_3 = 220$, then $n = ?$

Options:

- A. 11
- B. 12
- C. 10
- D. 9

Answer: B

Solution:

Solution:

We have, ${}^n C_3 = 220$

$$\Rightarrow \frac{n(n-1)(n-2)}{6} = 220$$

$$\Rightarrow n(n-1)(n-2) = 1320$$

$$\Rightarrow n = 12 [\because 12 \times 11 \times 10 = 1320]$$

Question 161

A multiple choice examination has 5 questions. Each question has three alternative answers of which exactly one is correct. The probability that a student will get 4 or more correct answer just by guessing, is

Options:

- A. $\frac{13}{3^5}$
- B. $\frac{11}{3^5}$
- C. $\frac{10}{3^5}$
- D. $\frac{17}{3^5}$

Answer: B

Solution:

Solution:

Total number of questions, $n = 5$

Probability of correct answer, $p = \frac{1}{3}$

Probability of incorrect answer, $q = \frac{2}{3}$

Required probability = $P(x \geq 4)$

= $p(x = 4) + p(x = 5)$

$$= {}^5C_4 \times \left(\frac{1}{3}\right)^4 \times \left(\frac{2}{3}\right)^1 + {}^5C_5 \left(\frac{1}{3}\right)^5 \times \left(\frac{2}{3}\right)^0$$

$$= \frac{10}{3^5} + \frac{1}{3^5} = \frac{11}{3^5}$$

Question 162

If $\sin A + \sin B = a$ and $\cos A + \cos B = b$, then $\cos(A + B)$ equals?

Options:

A. $\frac{a^2 + b^2}{b^2 - a^2}$

B. $\frac{2ab}{a^2 + b^2}$

C. $\frac{b^2 - a^2}{a^2 + b^2}$

D. $\frac{a^2 - b^2}{a^2 + b^2}$

Answer: C

Solution:

Solution:

Given, $\sin A + \sin B = a$(i)

$\cos A + \cos B = b$(ii)

Dividing Eq.(i) by Eq. (ii), we get

$$\frac{\sin A + \sin B}{\cos A + \cos B} = \frac{a}{b}$$

$$\Rightarrow \frac{2\sin\left(\frac{A+B}{2}\right)\cos\left(\frac{A-B}{2}\right)}{2\cos\left(\frac{A+B}{2}\right)\cos\left(\frac{A-B}{2}\right)} = \frac{a}{b}$$

$$\Rightarrow \tan\frac{A+B}{2} = \frac{a}{b} \text{(iii)}$$

$$\text{Now, } \cos(A+B) = \frac{1 - \tan^2\left(\frac{A+B}{2}\right)}{1 + \tan^2\left(\frac{A+B}{2}\right)} \left(\because \text{using } \cos\theta = \frac{1 - \tan^2\frac{\theta}{2}}{1 + \tan^2\frac{\theta}{2}} \right)$$

$$\Rightarrow \cos(A+B) = \frac{1 - \frac{a^2}{b^2}}{1 + \frac{a^2}{b^2}} \text{ [using Eq.(iii)]}$$

$$\therefore \cos(A+B) = \frac{b^2 - a^2}{b^2 + a^2}$$

Question 163

What is $\frac{\cos \theta}{1 - \tan \theta} + \frac{\sin \theta}{1 - \cot \theta}$ equal to?

Options:

- A. $\sin \theta - \cos \theta$
- B. $2\sin \theta$
- C. $\sin \theta + \cos \theta$
- D. $2 \cos \theta$

Answer: C

Solution:

Solution:

$$\begin{aligned}\frac{\cos \theta}{1 - \tan \theta} + \frac{\sin \theta}{1 - \cot \theta} &= \frac{\cos \theta}{1 - \frac{\sin \theta}{\cos \theta}} + \frac{\sin \theta}{1 - \frac{\cos \theta}{\sin \theta}} \\ &= \frac{\cos^2 \theta}{\cos \theta - \sin \theta} + \frac{\sin^2 \theta}{\sin \theta - \cos \theta} \\ &= \frac{\cos^2 \theta}{\cos \theta - \sin \theta} - \frac{\sin^2 \theta}{\cos \theta - \sin \theta} \\ &= \frac{\cos^2 \theta - \sin^2 \theta}{\cos \theta - \sin \theta} \\ &= \frac{(\cos \theta + \sin \theta)(\cos \theta - \sin \theta)}{(\cos \theta - \sin \theta)} \\ &= \sin \theta + \cos \theta\end{aligned}$$

[Using identity $a^2 - b^2 = (a + b)(a - b)$]

Question 164

Find the general solution of $\sin 2x + \cos x = 0$.

Options:

- A. $(n \pm 1) \frac{\pi}{2}$
- B. $n\pi \pm \frac{\pi}{2}$
- C. $n\pi + (-1)^n \frac{7\pi}{6}$ or $(2n \pm 1) \frac{\pi}{2}$
- D. None of the above

Answer: C

Solution:

Solution:

$$\begin{aligned}\sin 2x + \cos x &= 0 \\ \Rightarrow 2\sin x \cos x + \cos x &= 0 \\ \Rightarrow \cos x(2\sin x + 1) &= 0 \\ \Rightarrow \cos x = 0 \text{ or } 2\sin x + 1 &= 0 \\ \Rightarrow \cos x = \cos \frac{\pi}{2} \Rightarrow x = n\pi \pm \frac{\pi}{2}, n \in \mathbb{Z}\end{aligned}$$

$$\begin{aligned} \text{or } \sin x &= -\frac{1}{2} = -\sin\left(\frac{\pi}{6}\right) \\ &= \sin\left(\pi + \frac{\pi}{6}\right) \\ \Rightarrow \sin x &= \sin\left(\frac{7\pi}{6}\right) \\ \therefore x &= n\pi + (-1)^n \frac{7\pi}{6}, n \in \mathbb{Z} \end{aligned}$$

Question 165

If $f(x) + 2f(1-x) = x^2 + 5$ for all real values of x then $f(x)$ is given by

Options:

A. $x^2 - 5$

B. 2

C. $\frac{(x-2)^2 + 3}{3}$

D. None of these

Answer: C

Solution:

Solution:

Given, $f(x) + 2f(1-x) = x^2 + 5$ (i)

Replace $x \rightarrow 1-x$

$\therefore f(1-x) + 2f(x) = (1-x)^2 + 5$ (ii)

Multiplying Eq. (ii) by 2 and subtracting Eq. (i) from it

$\Rightarrow 2f(1-x) + 4f(x) - f(x) - 2f(1-x)$

$= 2(1-x)^2 + 5 \times 2 - x^2 - 5$

$\Rightarrow 3f(x) = 2(x^2 - 2x + 1) - x^2 + 5 = x^2 - 4x + 7$

$\therefore f(x) = \frac{(x-2)^2 + 3}{3}$

Question 166

If $A = \{3, 5, 7\}$ and $B = \{1, 2, 3, 5\}$, then $A \times B \cap B \times A$ is equal to

Options:

A. $\{(3, 3), (5, 3), (2, 7), (7, 2)\}$

B. $\{(3, 3), (3, 5), (5, 3), (5, 5)\}$

C. $\{(3, 3), (5, 5)\}$

D. $\{(3, 5), (5, 5), (5, 3)\}$

Answer: B

Solution:

Solution:

$A \times B = \{(3, 1), (3, 2), (3, 3), (3, 5), (5, 1), (5, 2), (5, 3), (5, 5), (7, 1), (7, 2), (7, 3), (7, 5)\}$
 $B \times A = \{(1, 3), (1, 5), (1, 7), (3, 3), (2, 5), (2, 7), (3, 3), (3, 5), (3, 7), (5, 3), (5, 5), (5, 7)\}$
 $\therefore A \times B \cap B \times A = \{(3, 3), (3, 5), (5, 3), (5, 5)\}$

Question 167

Total number of elements in the power set of A containing 17 elements is

Options:

- A. 2^{17+1}
- B. 2^{17-1}
- C. $17^2 - 1$
- D. 2^{17}

Answer: D

Solution:**Solution:**

For a given set A with n elements, number of elements in power set P(A) is 2^n .
Here, $n = 17$
 \therefore Power set contains 2^{17} elements.

Question 168

-The argument of $\frac{1 - i\sqrt{3}}{1 + i\sqrt{3}}$ is

Options:

- A. $\frac{\pi}{3}$
- B. $\frac{2\pi}{3}$
- C. $\frac{4\pi}{3}$
- D. $-\frac{2\pi}{3}$

Answer: D

Solution:**Solution:**

$$\frac{1 - i\sqrt{3}}{1 + i\sqrt{3}} = \frac{1 - i\sqrt{3}}{1 + i\sqrt{3}} \times \frac{1 - i\sqrt{3}}{1 - i\sqrt{3}} = \frac{(1 - i\sqrt{3})^2}{4}$$

[Using identity $(a + b)(a - b) = a^2 - b^2$]

$$= \frac{1 - 2\sqrt{3}i - 3}{4} = \frac{-2 - 2\sqrt{3}i}{4}$$

$$= \frac{-1}{2} - \frac{\sqrt{3}}{2}i$$

$$\therefore \arg\left(\frac{-1}{2} - \frac{\sqrt{3}}{2}i\right) = -(\pi - \tan^{-1}\sqrt{3}) = \frac{-2\pi}{3}$$

Question 169

Evaluate $\left[i^{22} + \left(\frac{1}{i} \right)^{25} \right]^3$

Options:

A. $4(i - 1)$

B. $2 - 7i$

C. $i - 1$

D. $2(1 - i)$

Answer: D

Solution:

Solution:

$$\left[i^{22} + \left(\frac{1}{i} \right)^{25} \right]^3 = \left[(i^2)^{11} + \frac{1}{(i^2)^{12}i} \right]^3$$

$$= \left[(-1)^{11} + \frac{1}{i} \right]^3 = \left(-1 + \frac{1}{i} \right)^3 [\because i^2 = -1]$$

$$= (-1)^3 + \left(\frac{1}{i} \right)^3 + 3(-1)\left(\frac{1}{i} \right) \left(-1 + \frac{1}{i} \right)$$

[Using $(a + b)^3 = a^3 + b^3 + 3ab(a + b)$]

$$= -1 + \frac{1}{i^2i} - \frac{3}{i} \left(-1 + \frac{1}{i} \right)$$

$$= -1 - \frac{1}{i} + \frac{3}{i} - \frac{3}{i^2}$$

$$= -1 + \frac{2}{i} + 3(\because i^2 = -1)$$

$$= 2 + \frac{2i}{1 \times 1} = 2 - 2i = 2(1 - i)$$

Question 170

$(i + \sqrt{3})^{100} + (i - \sqrt{3})^{100} + 2^{100}$ is equal to

Options:

A. 0

B. 1

C. -1

D. 2^{101}

Answer: A

Solution:

Solution:

$$(1 + \sqrt{3})^{100} = 1 \times (i + \sqrt{3})^{100} = i^{100}(i + \sqrt{3})^{100}$$

$$\text{(As } i^{4m} = 1, \text{ where } m = 25 \therefore i^{100} = 1)$$

$$= (i^2 + i\sqrt{3})^{100} = (-1 + i\sqrt{3})^{100} = (2\omega)^{100}$$

$$\text{Similarly, } (i - \sqrt{3})^{100} = (-1 + i\sqrt{3})^{100} = (2\omega^2)^{100}$$

$$\therefore (i + \sqrt{3})^{100} + (i - \sqrt{3})^{100} + 2^{100}$$

$$= (2\omega)^{100} + (2\omega^2)^{100} + 2^{100}$$

$$= 2^{100}(\omega^{100} + \omega^{200} + 1)$$

$$= 2^{100}(0) = 0$$

$$\therefore (i + \sqrt{3})^{100} + (i - \sqrt{3})^{100} + 2^{100} = 0$$

Question 171

There are 12 points in a plane out of which 3 points are collinear. How many straight lines can be drawn by joining any two of them?

Options:

A. 60

B. 64

C. 72

D. 84

Answer: B

Solution:

Solution:

From 12 given points ${}^{12}C_2$ straight lines can be drawn.

But 3 points are collinear, using 3 points 3C_2 straight lines can be drawn.

So, total straight lines without the straight line using three points $= {}^{12}C_2 - {}^3C_2$

From 3 collinear points 1 straight line can be drawn

So, total number of straight lines $= {}^{12}C_2 - {}^3C_2 + 1$

$$= \frac{12!}{2! \times 10!} - \frac{3!}{2! \times 1!} + 1$$

$$= \frac{12 \times 11 \times 10!}{2 \times 1 \times 10!} - \frac{3 \times 2!}{2! \times 1} + 1$$

$$= 66 - 3 + 1 = 64$$

Question 172

How many numbers greater than 50000 can be formed by using digits 2, 5, 5, 6, 7 ?

Options:

- A. 60
- B. 48
- C. 52
- D. 42

Answer: B

Solution:

Solution:

Total number formed by using 5 digits = $\frac{5!}{2!}$
 $= \frac{5 \times 4 \times 3 \times 2!}{2!} = 60$

For number greater than 50,000, digit 2 cannot come at first place.
Hence, number formed in which 2 is at the first place

$$= \frac{4!}{2!} = \frac{4 \times 3 \times 2!}{2!} = 12$$

Hence, total number formed greater than 50000
 $= 60 - 12 = 48$

Question 173

A regular polygon of n sides has 170 diagonals, then n is equal to

Options:

- A. -20
- B. -17
- C. 24
- D. 20

Answer: D

Solution:

Solution:

A polygon of n sides has number of diagonals = 170

$$\Rightarrow n \frac{(n-3)}{2} = 170$$

$$\Rightarrow n^2 - 3n = 340$$

$$\Rightarrow n^2 - 3n - 340 = 0$$

$$\Rightarrow n^2 - 20n + 17n - 340 = 0$$

$$\Rightarrow n(n-20) + 17(n-20) = 0$$

$$\Rightarrow (n-20)(n+17) = 0$$

$$\Rightarrow n-20 \text{ or } n+17 = 0$$

$$n = 20 \text{ or } n = -17 \text{ [it is not possible]}$$

$$\text{So, } n = 20$$

Question 174

Let the equation of the pair of lines $y = px$ and $y = qx$ can be written as $(y - px)(y - qx) = 0$. Then the equation of the pair of the angle bisectors of the line $x^2 - 4xy - 5y^2 = 0$ is

Options:

A. $x^2 - 3xy + y^2 = 0$

B. $x^2 + 4xy - y^2 = 0$

C. $x^2 + 3xy - y^2 = 0$

D. $x^2 - 3xy - y^2 = 0$

Answer: C

Solution:

Solution:

Equation of angle of equation of pair of straight line

$ax^2 + 2hxy + by^2$ is

$$\frac{x^2 - y^2}{a - b} = \frac{xy}{h}$$

For $x^2 - 4xy - 5y^2 = 0$

$a = 1, h = -2, b = -5$

So, equation of angle bisector is

$$\frac{x^2 - y^2}{1 - (-5)} = \frac{xy}{-2}$$

$$\Rightarrow x^2 - y^2 = -3xy$$

$$\Rightarrow x^2 + 3xy - y^2 = 0$$

Question 175

The distance of the point $(1, 2)$ from the line $x + y + 2 = 0$ measured along the line parallel to $2x - y = 5$ is equal to

Options:

A. $\frac{125}{3}$

B. $\frac{125}{\sqrt{3}}$

C. $\frac{5\sqrt{5}}{3}$

D. $\frac{5\sqrt{3}}{3}$

Answer: C

Solution:

Solution:

We know to find, PQ

IMAGE

The slope of the line $2x - y = 5$

$$\Rightarrow y = 2x - 5$$

On comparing with $y = mx + c$, we get

$$m = 2$$

Also, slope of PQ, $m_{PQ} = 2$

$$\text{Eq. of PQ, } (y - 2) = 2(x - 1)$$

$$\Rightarrow y - 2 = 2x - 2$$

$$\Rightarrow y = 2x$$

$$\text{So, from } x + y + 2 = 0 \Rightarrow x + 2x + 2 = 0$$

$$\Rightarrow 3x + 2 = 0 \Rightarrow x = -\frac{2}{3}$$

$$y = 2 \times -\frac{2}{3} = -\frac{4}{3}$$

\therefore The point Q is $\left(-\frac{2}{3}, -\frac{4}{3}\right)$

and P = (1, 2)

$$\text{Distance, PQ} = \sqrt{\left(-\frac{2}{3} - 1\right)^2 + \left(-\frac{4}{3} - 2\right)^2}$$

$$= \sqrt{\left(-\frac{5}{3}\right)^2 + \left(-\frac{10}{3}\right)^2}$$

$$= \sqrt{\frac{25}{9} + \frac{100}{9}} = \sqrt{\frac{125}{9}} = \frac{\sqrt{125}}{3} = \frac{5\sqrt{5}}{3}$$

Question 176

The slope of lines which makes an angle 45° with the line $2x - y = -7$

Options:

A. $\frac{1}{3}, -3$

B. $-1, 1$

C. $3, \frac{-1}{3}$

D. $1, \frac{1}{3}$

Answer: A

Solution:

Solution:

We have, $\theta = \frac{\pi}{4}$

Given, line is $2x - y = -7$

$$y = 2x + 7$$

Here, slope $m_1 = 2$

The required line makes an angle 45° with this line

$$\text{So, } \tan 45^\circ = \left| \frac{2 - m_2}{1 + 2m_2} \right|$$

$$\Rightarrow 1 + 2m_2 = 2 - m_2 \text{ or } 1 + 2m_2 = -(2 - m_2)$$

$$2m_2 + m_2 = 2 - 1 \text{ or } 1 + 2m_2 = -2 + m_2$$

$$\Rightarrow 3m_2 = 1 \Rightarrow 1m_2 - m_2 = -2 - 1$$

$$\therefore m_2 = \frac{1}{3}, m_2 = -3$$

Question 177

If 2 and 3 are intercepts of a line $L = 0$, then the distance of $L \equiv 0$ from the origin is

Options:

A. $\frac{5}{\sqrt{13}}$

B. $\frac{\sqrt{13}}{6}$

C. $\frac{6}{\sqrt{13}}$

D. 1

Answer: C

Solution:

Solution:

If 2, 3 are intercepts of a line $L = 0$, then

x - intercept = 2 = a

y - intercept = 3 = b

Equation of line is $\frac{x}{a} + \frac{y}{b} = 1$

$$\Rightarrow \frac{x}{2} + \frac{y}{3} = 1$$

$$\Rightarrow 3x + 2y - 6 = 0$$

∴ Required distance from origin is given by

$$= \left| \frac{3(0) + 2(0) - 6}{\sqrt{3^2 + 2^2}} \right| = \frac{|-6|}{\sqrt{13}} = \frac{6}{\sqrt{13}}$$

$$\therefore \text{Distance} = \frac{6}{\sqrt{13}} \text{ units}$$

Question 178

The total number of terms in the expansion of $(x + y)^{100} + (x - y)^{100}$ is

Options:

A. 49

B. 50

C. 51

D. 99

Answer: C

Solution:

Solution:

The expansion $(x + y)^{100} + (x - y)^{100}$ has

$$\left(\frac{100}{2} + 1 \right) = 51 \text{ terms}$$

Question 179

The coefficient of x^{20} in the expansion of $(1 + 3x + 3x^2 + x^3)^{20}$ is

Options:

A. ${}^{60}C_{40}$

B. ${}^{30}C_{20}$

C. ${}^{15}C_2$

D. None of these

Answer: A

Solution:

Solution:

Given expansion is $(1 + 3x + 2x^2 + x^3)^{20}$

$$= ((1 + x)^3)^{20}$$

$$= (1 + x)^{60} \dots\dots\dots(i)$$

In the expansion of $(a+b)^n$, $(r+1)$ th term given by

$$t_{r+1} = {}^n C_r a^r \cdot b^{n-r}$$

$$\text{or, } t_{r+1} = {}^n C_r a^{n-r} \cdot b^r$$

\therefore 21st term in Eq.(i) will contain the coefficient of x^{20} and it is given by

$$t_{21} = {}^{60}C_{20} x^{20}, 1^{40} = {}^{60}C_{20} x^{20}$$

\therefore Coefficient of x^{20} in $(1 + x)^{60}$ is ${}^{60}C_{20}$ or ${}^{60}C_{40}$.

Question 180

In the expansion of $(1 - 3x + 3x^2 - x^3)^{2n}$, the middle term is

Options:

A. $(n + 1)$ th term

B. $(2n + 1)$ th term

C. $(3n + 1)$ th term

D. None of these

Answer: C

Solution:

Solution:

Given expansion is $(1 - 3x + 3x^2 - x^3)^{2n}$

$$= [(1 - x)^3]^{2n}$$

$$= (1 - x)^{6n}$$

\therefore Middle term = $\frac{6n + 2}{2}$ th term [here, $6n$ is even]

$$= (3n + 1)\text{th term}$$
