



collegebatch.com

click to campus

BITSAT 2019 Question Paper with Answer Key

Birla Institute of Technology and Science Admission Test

Download BITSAT Previous Year Question Papers & Syllabus - [Click Here](#)

BITSAT : SOLVED PAPER 2019

(memory based)

INSTRUCTIONS

- This question paper contains total 150 questions divided into four parts:
 - Part I : Physics Q. No. 1 to 40
 - Part II : Chemistry Q. No. 41 to 80
 - Part III : (A) English Proficiency Q. No. 81 to 95
(B) Logical Reasoning Q. No. 96 to 105
 - Part IV : Mathematics Q. No. 106 to 150
- All questions are multiple choice questions with four options, only one of them is correct.
- Each correct answer awarded 3 marks and -1 for each incorrect answer.
- Duration of paper-3 Hours

PART - I : PHYSICS

1. Which one of the following graphs represents the variation of electric field with distance r from the centre of a charged spherical conductor of radius R ?

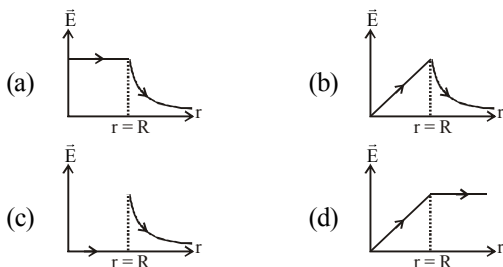

2. If \vec{E} and \vec{B} are the electric and magnetic field vectors of e.m. waves then the direction of propagation of e.m. wave is along the direction of
- (a) \vec{E} (b) \vec{B}
 (c) $\vec{E} \times \vec{B}$ (d) None of these
3. The young's modulus of a wire of length L and radius r is Y N/m². If the length and radius are reduced to $L/2$ and $r/2$, then its young's modulus will be
- (a) $Y/2$ (b) Y (c) $2Y$ (d) $4Y$
4. Twelve resistors each of resistance 16Ω are connected in the circuit as shown. The net resistance between A and B is

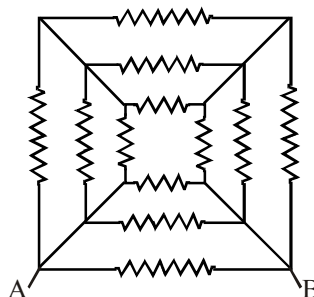

- (a) 1Ω (b) 2Ω
 (c) 3Ω (d) 4Ω
5. The time period of a satellite of earth is 5 hours. If the separation between the earth and the satellite is increased to 4 times the previous value, the new time period will become
- (a) 10 hours (b) 80 hours
 (c) 40 hours (d) 20 hours
6. Two trains are moving towards each other with speeds of 20 m/s and 15 m/s relative to the ground. The first train sounds a whistle of frequency 600 Hz. The frequency of the whistle heard by a passenger in the second train before the train meets, is (the speed of sound in air is 340 m/s)
- (a) 600 Hz (b) 585 Hz
 (c) 645 Hz (d) 666 Hz

7. You are asked to design a shaving mirror assuming that a person keeps it 10 cm from his face and views the magnified image of the face at the closest comfortable distance of 25 cm. The radius of curvature of the mirror would then be :

- (a) 60 cm (b) -24 cm
(c) -60 cm (d) 24 cm

8. A block is kept on a frictionless inclined surface with angle of inclination ' α '. The incline is given an acceleration ' a ' to keep the block stationary. Then ' a ' is equal to

- (a) $g \operatorname{cosec} \alpha$
(b) $g/\tan \alpha$
(c) $g \tan \alpha$
(d) g

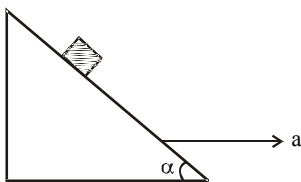

9. With the increase in temperature, the angle of contact

- (a) decreases
(b) increases
(c) remains constant
(d) sometimes increases and sometimes decreases

10. Forward biasing is that in which applied voltage

- (a) increases potential barrier
(b) cancels the potential barrier
(c) is equal to 1.5 volt
(d) None of these

11. Number of significant figures in expression

$$\frac{4.327 \text{ g}}{2.51 \text{ cm}^3} \text{ is}$$

- (a) 2 (b) 4 (c) 3 (d) 5

12. The ratio of the specific heats $\frac{C_p}{C_v} = \gamma$ in terms of degrees of freedom (n) is given by

- (a) $\left(1 + \frac{n}{3}\right)$ (b) $\left(1 + \frac{2}{n}\right)$
(c) $\left(1 + \frac{n}{2}\right)$ (d) $\left(1 + \frac{1}{n}\right)$

13. A stone is thrown with a velocity u making an angle θ with the horizontal. The horizontal distance covered by its fall to ground is maximum when the angle θ is equal to

- (a) 0° (b) 30° (c) 45° (d) 90°

14. A ball of mass 150 g, moving with an acceleration 20 m/s^2 , is hit by a force, which acts on it for 0.1 sec. The impulsive force is

- (a) 0.5 N (b) 0.1 N (c) 0.3 N (d) 1.2 N

15. A man drags a block through 10 m on rough surface ($\mu = 0.5$). A force of $\sqrt{3}$ kN acting at 30° to the horizontal. The work done by applied force is

- (a) zero (b) 7.5 kJ (c) 5 kJ (d) 10 kJ

16. A force of $2\hat{i} + 3\hat{j} + 4\hat{k}$ N acts on a body for 4 second, produces a displacement of $(3\hat{i} + 4\hat{j} + 5\hat{k})$ m. The power used is

- (a) 9.5 W (b) 7.5 W (c) 6.5 W (d) 4.5 W

17. The Earth is assumed to be a sphere of radius R . A platform is arranged at a height R from the surface of the Earth. The escape velocity of a body from this platform is fv , where v is its escape velocity from the surface of the Earth. The value of f is

- (a) $\frac{1}{3}$ (b) $\frac{1}{2}$ (c) $\sqrt{2}$ (d) $\frac{1}{\sqrt{2}}$

18. Kepler's second law regarding constancy of areal velocity of a planet is a consequence of the law of conservation of

- (a) Energy
(b) Angular momentum
(c) Linear momentum
(d) None of these

19. Water is flowing through a horizontal tube having cross-sectional areas of its two ends being A and A' such that the ratio A/A' is 5. If the pressure difference of water between the two ends is $3 \times 10^5 \text{ N m}^{-2}$, the velocity of water with which it enters the tube will be (neglect gravity effects)

- (a) 5 m s^{-1} (b) 10 m s^{-1}
(c) 25 m s^{-1} (d) $50\sqrt{10} \text{ m s}^{-1}$

20. A thermodynamic system is taken from state A to B along ACB and is brought back to A along BDA as shown in the PV diagram. The net work done during the complete cycle is given by the area

- (a) $P_1ACBP_2P_1$
(b) $ACBB'A'A$
(c) $ACBDA$
(d) $A'DBB'A'A$

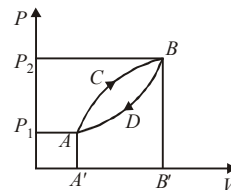

21. A boat crosses a river from port A to port B, which are just on the opposite side. The speed of the water is V_w and that of boat is V_B relative to still water. Assume $V_w = 2V_B$. What is the time taken by the boat, if it has to cross the river directly on the AB line [D = width of the river]

- (a) $\frac{2D}{V_B\sqrt{3}}$ (b) $\frac{\sqrt{3}D}{2V_B}$
 (c) $\frac{D}{V_B\sqrt{2}}$ (d) $\frac{D\sqrt{2}}{V_B}$

22. Two springs, of force constants k_1 and k_2 are connected to a mass m as shown. The frequency of oscillation of the mass is f . If both k_1 and k_2 are made four times their original values, the frequency of oscillation becomes

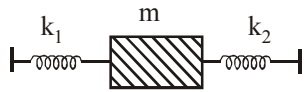

- (a) $2f$ (b) $f/2$ (c) $f/4$ (d) $4f$

23. When a potential difference V is applied across a conductor at a temperature T , the drift velocity of electrons is proportional to

- (a) \sqrt{V} (b) V (c) \sqrt{T} (d) T

24. The amplitude of a damped oscillator becomes $(\frac{1}{3})^{\text{rd}}$ in 2 seconds. If its amplitude after 6 seconds is $\frac{1}{n}$ times the original amplitude, the value of n is

- (a) 3^2 (b) 3^3 (c) $\sqrt[3]{3}$ (d) 2^3

25. The angular speed of the electron in the n^{th} orbit of Bohr hydrogen atom is

- (a) directly proportional to n
 (b) inversely proportional to \sqrt{n}
 (c) inversely proportional to n^2
 (d) inversely proportional to n^3

26. In the given figure, the charge on $3\mu\text{F}$ capacitor is

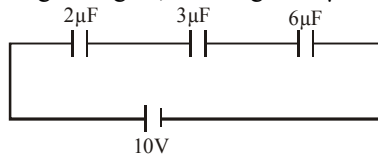

- (a) $10\mu\text{C}$ (b) $15\mu\text{C}$
 (c) $30\mu\text{C}$ (d) $5\mu\text{C}$

27. Two bodies A and B are placed in an evacuated vessel maintained at a temperature of 27°C . The temperature of A is 327°C and that of B is 227°C . The ratio of heat loss from A and B is about

- (a) 2 : 1 (b) 1 : 2 (c) 4 : 1 (d) 1 : 4

28. If a rigid body is rotating about an axis with a constant velocity, then

- (a) Velocity, Angular velocity of all particles will be same
 (b) Velocity, Angular velocity of all particles will be different
 (c) Velocity of all particles will be different but angular velocity will be same.
 (d) Angular velocity of all particles will be different but velocity will be same.

29. The fundamental frequency of an open organ pipe is 300 Hz. The first overtone of this pipe has same frequency as first overtone of a closed organ pipe. If speed of sound is 330 m/s, then the length of closed organ pipe is

- (a) 41 cm (b) 30 cm (c) 45 cm (d) 35 cm

30. In Young's experiment, the distance between the slits is reduced to half and the distance between the slit and screen is doubled, then the fringe width

- (a) will not change
 (b) will become half
 (c) will be doubled
 (d) will become four times

31. If a rolling body's angular momentum changes by 20 SI units in 3 seconds, by a constant torque. Then find the torque on the body

- (a) $20/3$ SI units (b) $100/3$ SI units
 (c) 20 SI units (d) 5 SI units

32. Charge Q is distributed to two different metallic spheres having radii x and $2x$ such that both spheres have equal surface charge density, then charge on large sphere is

- (a) $\frac{4Q}{5}$ (b) $\frac{Q}{5}$ (c) $\frac{3Q}{5}$ (d) $\frac{5Q}{4}$

33. In an LR circuit $f = 50$ Hz, $L = 2$ H, $E = 5$ volts, $R = 1\ \Omega$ then energy stored in inductor is

- (a) 50 J (b) 25 J
 (c) 100 J (d) None of these

34. A straight wire of length 0.5 metre and carrying a current of 1.2 ampere is placed in uniform magnetic field of induction 2 tesla. The magnetic field is perpendicular to the length of the wire. The force on the wire is

- (a) 2.4 N (b) 1.2 N (c) 3.0 N (d) 2.0 N

35. A man drives a car from station B towards station A at speed 60 km/h. A car leaves station A for station B every 10 min. The distance between A and B is 60 km. The car travels at the speed of 60 km/h. A man drives a car from B towards A at speed of 60 km/h. If he starts at the moment when first car leaves the station B, then how many cars would be meet on the route ?

- (a) 4 (b) 7 (c) 9 (d) 12

36. In rotatory motion, linear velocities of all the particles of the body are

- (a) same (b) different
(c) zero (d) cannot say

37. If x , v and a denote the displacement, the velocity and the acceleration of a particle executing simple harmonic motion of time period T , then, which of the following does not change with time?

- (a) aT/x (b) $aT + 2\pi v$
(c) aT/v (d) $a^2T^2 + 4\pi^2v^2$

38. A conducting wire frame is placed in a magnetic field which is directed into the paper. The magnetic field is increasing at a constant rate. The directions of induced current in wires AB and CD are

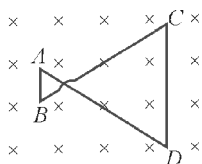

- (a) B to A and D to C (b) A to B and C to D
(c) A to B and D to C (d) B to A and C to D

39. Find the acceleration of block A and B. Assume pulley is massless.

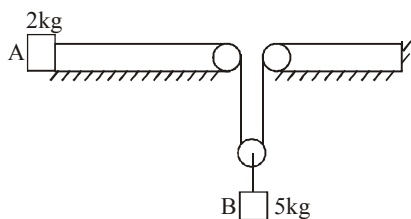

- (a) $\frac{10}{13} \text{ g}$, $\frac{5}{13} \text{ g}$ (b) $\frac{1}{13} \text{ g}$, $\frac{5}{13} \text{ g}$
(c) $\frac{9}{13} \text{ g}$, $\frac{11}{13} \text{ g}$ (d) $\frac{13}{10} \text{ g}$, $\frac{13}{5} \text{ g}$

40. The nuclei of which one of the following pairs of nuclei are isotones?

- (a) ${}_{34}\text{Se}^{74}$, ${}_{31}\text{Ga}^{71}$
(b) ${}_{38}\text{Sr}^{84}$, ${}_{38}\text{Sr}^{86}$
(c) ${}_{42}\text{Mo}^{92}$, ${}_{40}\text{Zr}^{92}$
(d) ${}_{20}\text{Ca}^{40}$, ${}_{16}\text{S}^{32}$

PART - II : CHEMISTRY

41. Plots showing the variation of the rate constant (k) with temperature (T) are given below. The plot that follows Arrhenius equation is

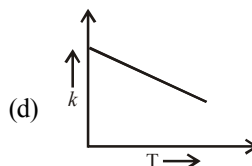
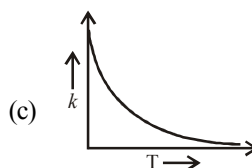
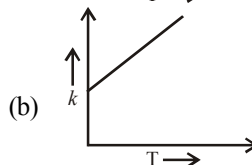
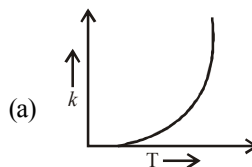

42. 3.6 g of oxygen is adsorbed on 1.2 g of metal powder. What volume of oxygen adsorbed per gram of the adsorbent at 1 atm and 273 K?

- (a) 0.19 L g⁻¹ (b) 1 L g⁻¹
(c) 2.1 L g⁻¹ (d) None of these

43. In the purification of impure nickel by Mond's process, metal is purified by :

- (a) Electrolytic reduction
(b) Vapour phase thermal decomposition
(c) Thermite reduction
(d) Carbon reduction

44. When chlorine water is added to an aqueous solution of sodium iodide in the presence of chloroform, a violet colouration is obtained. On adding more of chlorine water and vigorous shaking, the violet colour disappears. This shows the conversion of into

- (a) I_2, HIO_3 (b) I_2, HI
(c) HI, HIO_3 (d) I_2, HOI

45. In the clathrates of xenon with water, the nature of bonding between xenon and water molecule is

- (a) covalent
(b) hydrogen bonding
(c) coordinate
(d) dipole-induced dipole

46. The electronic configurations of Eu (Atomic No. 63), Gd (Atomic No. 64) and Tb (Atomic No. 65) are

- (a) $[Xe]4f^76s^2, [Xe]4f^86s^2$ and $[Xe]4f^85d^16s^2$
(b) $[Xe]4f^75d^16s^2, [Xe]4f^75d^16s^2$ and $[Xe]4f^96s^2$
(c) $[Xe]4f^65d^16s^2, [Xe]4f^75d^16s^2$ and $[Xe]4f^85d^16s^2$
(d) $[Xe]4f^76s^2, [Xe]4f^75d^16s^2$ and $[Xe]4f^96s^2$

47. Which of the following carbonyls will have the strongest C – O bond ?

- (a) $[Mn(CO)_6]^+$ (b) $[Cr(CO)_6]$
(c) $[V(CO)_6]^-$ (d) $[Fe(CO)_5]$

48. How many chiral compounds are possible on monochlorination of 2-methyl butane ?

- (a) 8 (b) 2 (c) 4 (d) 6

49. Which of the following are intermediates in the reaction of excess of CH_3MgBr with $C_6H_5COOC_2H_5$ to make 2-phenyl-2-propanol ?

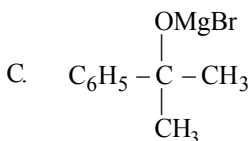
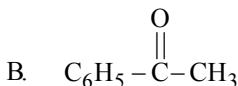
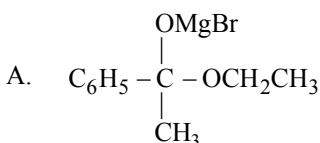

- (a) A and B (b) A, B and C
(c) A and C (d) B and C

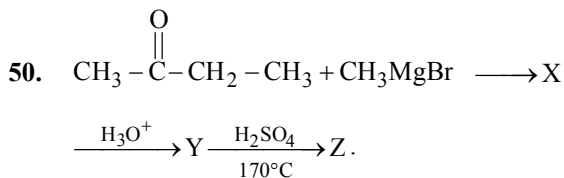

What is Z?

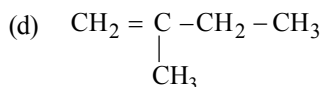
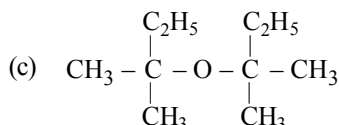
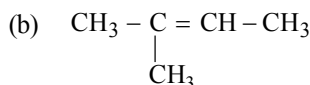
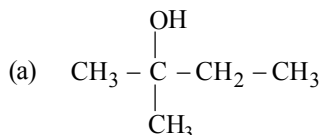

51. Which of the following is the strongest base ?

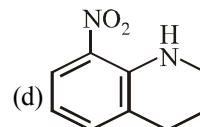
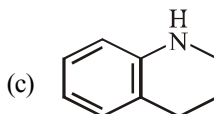
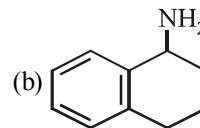
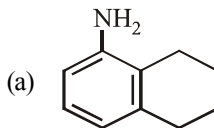

52. Which of the following does not reduce Benedict's solution?

- (a) Glucose (b) Fructose
(c) Sucrose (d) Aldehyde

53. General formula of solid in zinc blende structure is:

- (a) AB_2 (b) AB_3 (c) AB (d) A_2B

54. Glycine in alkaline solution exists as _____ and migrates to _____.

- (a) Cation, cathode
(b) Neutral, anode
(c) Zwitter ion, cathode
(d) anion, anode

55. Product on reaction of ethanamide with phosphorus pentoxide is:
 (a) ethanamine
 (b) acetonitrile
 (c) ethanol
 (d) ethane isonitrile
56. K_a of HX is 10^{-5} , then find concentration of H_3O^+ when equal volumes of 0.25M HX and 0.05 M NaOH are mixed.
 (a) 4×10^{-5} M (b) 6×10^{-5} M
 (c) 8×10^{-3} M (d) 2×10^{-5} M
57. Net cell reaction of Pt | H_2 (640 mm) | HCl | H_2 (510 mm) | Pt.
 (a) 0.89 V (b) 0.93 V
 (c) 2.91×10^{-3} V (d) 2.5×10^{-2} V
58. Which of the following has zero net dipole moment?
 (a) XeF_4 (b) BrF_3 (c) ClF_3 (d) SF_4
59. Which of the following element has the highest ionisation enthalpy?
 (a) Boron (b) Aluminium
 (c) Germanium (d) Thallium
60. Out of the elements with atomic number 7, 8, 9, 13 which has the smallest size and highest ionization enthalpy?
 (a) 7 (b) 8 (c) 9 (d) 13
61. Which one is classified as a condensation polymer?
 (a) Dacron (b) Neoprene
 (c) Teflon (d) Acrylonitrile
62. Which of the following compounds is not an antacid?
 (a) Phenelzine (b) Ranitidine
 (c) Aluminium hydroxide (d) Cimetidine
63. Mole fraction of the solute in a 1.00 molal aqueous solution is
 (a) 0.1770 (b) 0.0177 (c) 0.0344 (d) 1.7700
64. The IUPAC name of the following compound is
-
- (a) *trans*-2-chloro-3-iodo-2-pentene
 (b) *cis*-3-iodo-4-chloro-3-pentene
 (c) *trans*-3-iodo-4-chloro-3-pentene
 (d) *cis*-2-chloro-3-iodo-2-pentene
65. Most stable carbocation among the following is:
- (a)
- (b)
- (c)
- (d) $^+CH_3$
66. Which is correct for the following changes ?
- $$A \xrightarrow{X} B \xrightarrow{\text{Baeyer's reagent}} \begin{array}{c} \text{Me} \\ | \\ \text{H} - \text{C} - \text{OH} \\ | \\ \text{H} - \text{C} - \text{OH} \\ | \\ \text{Me} \end{array}$$
- (a) X is Lindlar Catalyst, B is *cis*-2-butene
 (b) A is 2-butyne, X is Na-liq. NH_3
 (c) B is *trans*-2-butene, X is Na-liq. NH_3
 (d) A is 2-butene, X is SeO_2
67. The stability of +1 oxidation state among Al, Ga, In and Tl increases in the sequence :
 (a) $Ga < In < Al < Tl$
 (b) $Al < Ga < In < Tl$
 (c) $Tl < In < Ga < Al$
 (d) $In < Tl < Ga < Al$
68. Which of the following alkaline earth metal hydroxides is amphoteric in character?
 (a) $Be(OH)_2$ (b) $Ca(OH)_2$
 (c) $Sr(OH)_2$ (d) $Ba(OH)_2$
69. Which reaction shows oxidising nature of H_2O_2 ?
 (a) $H_2O_2 + 2KI \longrightarrow 2KOH + I_2$
 (b) $Cl_2 + H_2O_2 \longrightarrow 2HCl + O_2$
 (c) $H_2O_2 + Ag_2O \longrightarrow 2Ag + H_2O + O_2$
 (d) $NaClO + H_2O_2 \longrightarrow NaCl + H_2O + O_2$
70. $aK_2Cr_2O_7 + bKCl + cH_2SO_4 \longrightarrow xCrO_2 + Cl_2 + yKHSO_4 + zH_2O$
 The above equation balances when
 (a) $a = 2, b = 4, c = 6$ and $x = 2, y = 6, z = 3$
 (b) $a = 4, b = 2, c = 6$ and $x = 6, y = 2, z = 3$
 (c) $a = 6, b = 4, c = 2$ and $x = 6, y = 3, z = 2$
 (d) $a = 1, b = 4, c = 6$ and $x = 2, y = 6, z = 3$

71. For the reactions

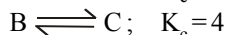

K_c for the reaction $A \rightleftharpoons D$ is

(a) $2 \times 4 \times 6$ (b) $\frac{2 \times 4}{6}$

(c) $2 + 4 + 6$ (d) $\frac{4 \times 6}{2}$

72. Which of the following will always lead to a non-spontaneous change?

- (a) ΔH and ΔS both +ve
 (b) ΔH is -ve ΔS both +ve
 (c) ΔH and ΔS both -ve
 (d) ΔH is +ve ΔS both -ve

73. The densities of two gasses are in the ratio of 1:16. The ratio of their rates of diffusion is

- (a) 16:1 (b) 4:1 (c) 1:4 (d) 1:16

74. In the reaction $2\text{PCl}_5 \rightleftharpoons \text{PCl}_4^+ + \text{PCl}_6^-$, the change in hybridisation is from

- (a) sp^3d to sp^3 and sp^3d^2
 (b) sp^3d to sp^2 and sp^3
 (c) sp^3d to sp^3d^2 and sp^3d^3
 (d) sp^3d^2 to sp^3 and sp^3d

75. The group having isoelectronic species is:

- (a) O^{2-} , F^- , Na^+ , Mg^{2+}
 (b) O^- , F^- , Na , Mg^+
 (c) O^{2-} , F^- , Na , Mg^{2+}
 (d) O^- , F^- , Na^+ , Mg^{2+}

76. 100 mL O_2 and H_2 kept at same temperature and pressure. What is true about their number of molecules

- (a) $N_{\text{O}_2} > N_{\text{H}_2}$
 (b) $N_{\text{O}_2} < N_{\text{H}_2}$
 (c) $N_{\text{O}_2} = N_{\text{H}_2}$
 (d) $N_{\text{O}_2} + N_{\text{H}_2} = 1 \text{ mole}$

77. If m_A gram of a metal A displaces m_B gram of another metal B from its salt solution and if the equivalent mass are E_A and E_B respectively then equivalent mass of A can be expressed as:

(a) $E_A = \frac{m_A}{m_B} \times E_B$

(b) $E_A = \frac{m_A \times m_B}{E_B}$

(c) $E_A = \frac{m_B}{m_A} \times E_B$

(d) $E_A = \sqrt{\frac{m_A}{m_B}} \times E_B$

78. Which one of the following set of quantum numbers is not possible for 4p electron?

(a) $n=4, l=1, m=-1, m_s = +\frac{1}{2}$

(b) $n=4, l=1, m=0, m_s = +\frac{1}{2}$

(c) $n=4, l=1, m=2, m_s = +\frac{1}{2}$

(d) $n=4, l=1, m=-1, m_s = -\frac{1}{2}$

79. Which of the following radial distribution graphs correspond to $l=2$ for the H atom?

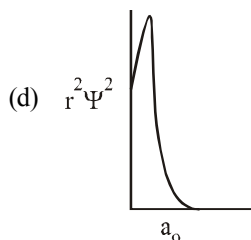
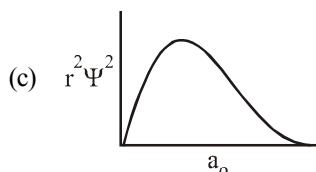
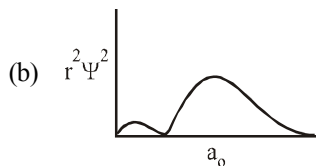
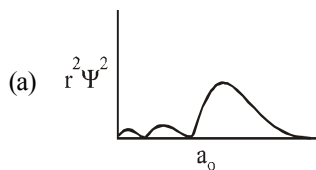

80. Which of the following is paramagnetic?

- (a) B_2 (b) C_2 (c) N_2 (d) F_2

PART - III (A): ENGLISH PROFICIENCY

DIRECTIONS (Qs. 81-83) : *In the following questions below, out of the four alternatives, choose the one which best expresses the meaning of the given word.*

81. Garrulous
(a) Talkative (b) Sedative
(c) Cocative (d) Positive
82. Tinsel
(a) Tinkle (b) Decoration
(c) Tin (d) Colourful
83. Labyrinth
(a) Meandering (b) Rotating
(c) Pacing (d) Wriggling

DIRECTIONS (Qs. 84-86) : *In the following questions, choose the word opposite in meaning to the given word.*

84. Knack :
(a) Talent (b) Dullness
(c) Dexterity (d) Balance
85. Pernicious :
(a) Prolonged (b) Ruinous
(c) Ruthless (d) Beneficial
86. Opulence :
(a) Luxury (b)
Transparency
(c) Weath (d) Poverty

DIRECTIONS (Qs. 87-90) : *Read the passage carefully and choose the best answer to each question out of the four alternatives and mark it by blackening the appropriate circle [•].*

Like watering a plant, we grow our friendships [and all our relationships] by running them. Friendships need the same attention as other relationships. If they are to continue. These relationships can be delightfully non-judgemental, supportive, understanding and fun.

Sometimes a friendship can bring out the positive side that you never show in any other relationship. This may be because the pressure of playing a 'role' (daughter, partner or child) is removed. With a friend you are to be yourself and free to change. Of course, you are free to do this in all other relationships as well, but in friendships you get to have lats of rehearsals and discussion about changes

as you experience them. It is an unconditional experience where you receive as much as you give. You can explain yourself to a friend openly without the fear of hurting a family member. How do friendships grow ? The answer is simple. By revealing yourself; being attentive: remembering what is most showing empathy; seeing the world through the eyes of your friend, you will understand the value of friendship. All this means learning to accept a person from a completely different family to your own or perhaps someone from a completely different cultural background. This is the way we learn tolerance. In turn we gain tolerance and acceptance for our own differences.

87. In good friendships, we
(a) give and receive.
(b) neither give nor receive.
(c) only give.
(d) only receive.
88. Empathy means
(a) someone else's misfortunes
(b) the ability to share and understand another feelings.
(c) skill and efficiency
(d) ability to do something
89. Through strong friendships, we gain
(a) only acceptance.
(b) only attention.
(c) acceptance and tolerance.
(d) only tolerance.
90. Friendships and relationships grow when they are
(a) compared (b) divided
(c) favoured (d) nurtured

DIRECTIONS (Qs. 91-92) : *In the following questions, sentences are given with blanks to be filled with an appropriate word(s). Four alternatives are suggested for each question. Choose the correct alternative out of the four as your answer.*

91. There are not solitary, free-living creatures ; every form of life is _____ other forms.
(a) dependent on (b) parallel to
(c) overshadowed by (d) segregated from
92. I'll take _____ now as I have another's appointment some where else.
(a) departure (b) your leave
(c) permission (d) leave from work

DIRECTIONS (Qs. 93-95): In the following questions, some parts of the sentences have errors and some are correct. Find out which part of a sentence has an error. The number of that part is the answer. If a sentence is free from error, then your answer is (d). i.e., No error.

93. When one hears of the incident (a)/about the plane crash (b)/ he feels very sorry. (c)/ No error (d)
94. I went there (a)/ with a view to survey (b)/ the entire procedure. (c)/ No error (d)
95. It had laid (a)/ in the closet (b)/ for a week before we found it. (c)/ No error (d)

PART - III (B) : LOGICAL REASONING

DIRECTIONS (Qs. 96 & 97) : In the following questions, which answer figure will complete the question figure?

96. Question Figures :

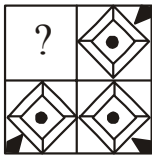

Answer figures :

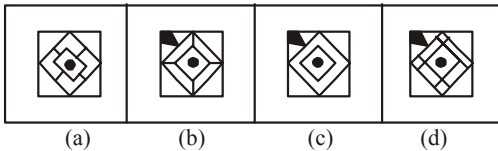

97. Question Figure:

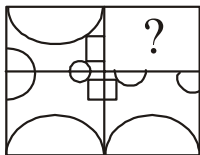

Answer Figure:

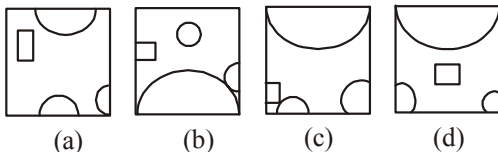

98. A piece of paper is folded and cut/punched as shown below in the question figures. From the given answer figures, indicate how it will appear when opened.

Question figures:

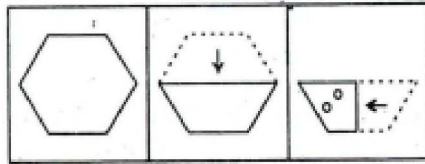

Answer figures:

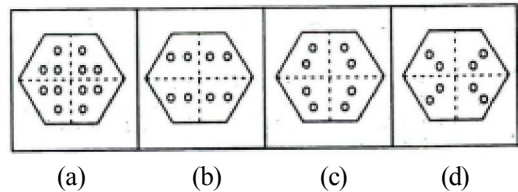

99. Select the related word from the given alternatives:

Medicine : Patient :: Education : ?

- (a) Teacher (b) School
(c) Student (d) Tuition

100. Choose the correct alternative from the given ones that will complete the series.

A3E, F5J, K7O, _____

- (a) Q11T (b) Q9V
(c) P9T (d) P11T

101. Which one of the following numbers lacks the common property in the series?

81, 36, 25, 9, 5, 16

- (a) 5 (b) 9
(c) 36 (d) 25

102. In a certain code language, "TIRED" is written as "56" and "BRAIN" is written as "44". How is "LAZY" written in that code language?

- (a) 64 (b) 61
(c) 58 (d) 43

103. Select the missing number from the given response.

8	7	6
8	7	6
88	77	?
5632	3773	3132

- (a) 66 (b) 87 (c) 78 (d) 76

104. Which one of the following diagrams best depicts the relationship among Human Society - Youth Club, Political Party and Youths ?

- (a)  (b) 
 (c)  (d) 

105. Among her children, Ganga's favourites are Ram and Rekha. Rekha is the mother of Sharat, who is loved most by his uncle Mithun. The head of the family is Ram Lal, who is succeeded by his sons Gopal and Mohan. Gopal and Ganga have been married for 35 years and have 3 children. What is the relation between Mithun and Mohan?

- (a) Uncle (b) Son
 (c) Brother (d) No relation

PART - IV : MATHEMATICS

106. If $x \cos \alpha + y \sin \alpha = P$ is a tangent to the ellipse

$$\frac{x^2}{a^2} + \frac{y^2}{b^2} = 1, \text{ then}$$

- (a) $a \cos \alpha + b \sin \alpha = P^2$
 (b) $a \sin \alpha + b \cos \alpha = P^2$
 (c) $a^2 \cos^2 \alpha + b^2 \sin^2 \alpha = P^2$
 (d) $a^2 \sin^2 \alpha + b^2 \cos^2 \alpha = P^2$

107. If $a_1, a_2, a_3, \dots, a_n$ are in A.P. where $a_i > 0$ for all i , then

$$\frac{1}{\sqrt{a_1} + \sqrt{a_2}} + \frac{1}{\sqrt{a_2} + \sqrt{a_3}} + \dots + \frac{1}{\sqrt{a_{n-1}} + \sqrt{a_n}} =$$

- (a) $\frac{n+1}{\sqrt{a_1} + \sqrt{a_n}}$ (b) $\frac{n}{\sqrt{a_1} + \sqrt{a_n}}$
 (c) $\frac{n-1}{\sqrt{a_1} + \sqrt{a_n}}$ (d) none of these

108. In order to solve the differential equation

$$x \cos x \frac{dy}{dx} + y(x \sin x + \cos x) = 1$$

the integrating factor is:

- (a) $x \cos x$ (b) $x \sec x$
 (c) $x \sin x$ (d) $x \operatorname{cosec} x$

109. Equation of two straight lines are

$$\frac{x-1}{2} = \frac{y-2}{3} = \frac{z-3}{4} \text{ and } \frac{x-4}{5} = \frac{y-1}{2} = z.$$

Then

- (a) The lines are non-coplanar
 (b) The lines are parallel and distinct
 (c) The lines intersect in unique point
 (d) The lines are coincident

110. The equation of the curve passing through the

point $\left(a, -\frac{1}{a}\right)$ and satisfying the differential

$$\text{equation } y - x \frac{dy}{dx} = a \left(y^2 + \frac{dy}{dx} \right) \text{ is}$$

- (a) $(x+a)(1+ay) = -4a^2y$
 (b) $(x+a)(1-ay) = 4a^2y$
 (c) $(x+a)(1-ay) = -4a^2y$
 (d) None of these

111. The locus of the mid-point of a chord of the circle

$x^2 + y^2 = 4$, which subtends a right angle at the origin is

- (a) $x+y=2$ (b) $x^2+y^2=1$
 (c) $x^2+y^2=2$ (d) $x+y=1$

112. With the usual notation $\int_1^2 ([x^2] - [x]^2) dx$ is equal to

- (a) $4 + \sqrt{2} - \sqrt{3}$ (b) $4 - \sqrt{2} + \sqrt{3}$
 (c) $4 - \sqrt{2} - \sqrt{3}$ (d) none of these

113. $\frac{1 + \sin A - \cos A}{1 + \sin A + \cos A} =$

- (a) $\sin \frac{A}{2}$ (b) $\cos \frac{A}{2}$
 (c) $\tan \frac{A}{2}$ (d) $\cot \frac{A}{2}$

114. If $x\sqrt{1+y} + y\sqrt{1+x} = 0$, then $\frac{dy}{dx} =$

- (a) $\frac{x+1}{x}$ (b) $\frac{1}{1+x}$
 (c) $\frac{-1}{(1+x)^2}$ (d) $\frac{x}{1+x}$

115. If $f(x) = 3x^4 + 4x^3 - 12x^2 + 12$, then $f(x)$ is
 (a) increasing in $(-\infty, -2)$ and in $(0, 1)$
 (b) increasing in $(-2, 0)$ and in $(1, \infty)$
 (c) decreasing in $(-2, 0)$ and in $(0, 1)$
 (d) decreasing in $(-\infty, -2)$ and in $(1, \infty)$
116. Consider $\frac{x}{2} + \frac{y}{4} \geq 1$ and $\frac{x}{3} + \frac{y}{2} \leq 1$, $x, y \geq 0$.

Then number of possible solutions are :

- (a) Zero (b) Unique
 (c) Infinite (d) None of these
117. The distance of a point $(2, 5, -3)$ from the plane $r \cdot (6\hat{i} - 3\hat{j} + 2\hat{k}) = 4$ is

- (a) 13 (b) $\frac{13}{7}$
 (c) $\frac{13}{5}$ (d) $\frac{37}{7}$

118. The value of definite integral $\int_0^{\frac{\pi}{2}} \log(\tan x) dx$ is

- (a) 0 (b) $\frac{\pi}{4}$
 (c) $\frac{\pi}{2}$ (d) π

119. For the following feasible region, the linear constraints are

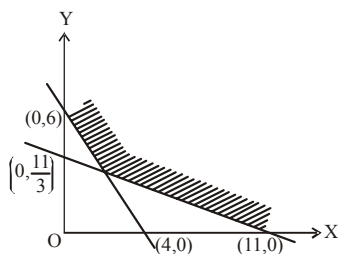

- (a) $x \geq 0, y \geq 0, 3x + 2y \geq 12, x + 3y \geq 11$
 (b) $x \geq 0, y \geq 0, 3x + 2y \leq 12, x + 3y \geq 11$
 (c) $x \geq 0, y \geq 0, 3x + 2y \leq 12, x + 3y \leq 11$
 (d) None of these
120. The general solution of differential equation $(e^x + 1) y dy = (y + 1) e^x dx$ is
 (a) $(y + 1) = k(e^x + 1)$
 (b) $y + 1 = e^x + 1 + k$
 (c) $y = \log \{k(y + 1)(e^x + 1)\}$
 (d) $y = \log \left\{ \frac{e^x + 1}{y + 1} \right\} + k$

121. What is the slope of the normal at the point $(at^2, 2at)$ of the parabola $y^2 = 4ax$?

- (a) $\frac{1}{t}$ (b) t
 (c) $-t$ (d) $-\frac{1}{t}$

122. $\int_0^{\pi/2} x \sin^2 x \cos^2 x dx$ is equal to

- (a) $\frac{\pi^2}{32}$ (b) $\frac{\pi^2}{16}$
 (c) $\frac{\pi}{32}$ (d) None of these

123. If $\begin{vmatrix} 6i & -3i & 1 \\ 4 & 3i & -1 \\ 20 & 3 & i \end{vmatrix} = x + iy$, where $i = \sqrt{-1}$, then

what is x equal to ?

- (a) 3 (b) 2
 (c) 1 (d) 0

124. The limit $\lim_{x \rightarrow 0} \left(\frac{\log_e(1+x)}{x^2} + \frac{x-1}{x} \right)$

- (a) is equal to $\frac{1}{2}$ (b) is equal to $-\frac{1}{2}$
 (c) is equal to 2 (d) does not exist

125. If $2 \cos^2 x + 3 \sin x - 3 = 0$, $0 \leq x \leq 180^\circ$, then $x =$

- (a) $30^\circ, 90^\circ, 150^\circ$ (b) $60^\circ, 120^\circ, 180^\circ$
 (c) $0^\circ, 30^\circ, 150^\circ$ (d) $45^\circ, 90^\circ, 135^\circ$

126. If the number of available constraints is 3 and the number of parameters to be optimized is 4, then

- (a) The objective function can be optimized
 (b) The constraint are short in number
 (c) The solution is problem oriented
 (d) None of these

127. If $y = \tan^{-1} \left(\frac{\sqrt{x-x}}{1+x^{3/2}} \right)$, then $y'(1)$ is equal to

- (a) 0 (b) $\frac{1}{2}$ (c) -1 (d) $-\frac{1}{4}$

128. The maximum area of rectangle inscribed in a circle of diameter R is

- (a) R^2 (b) $\frac{R^2}{2}$
 (c) $\frac{R^2}{4}$ (d) $\frac{R^2}{8}$

129. If A and B are two events, such that

$$P(A \cup B) = \frac{3}{4}, P(A \cap B) = \frac{1}{4}, P(A^c) = \frac{2}{3}$$

where A^c stands for the complementary event of A, then $P(B)$ is given by:

- (a) $\frac{1}{3}$ (b) $\frac{2}{3}$
 (c) $\frac{1}{9}$ (d) $\frac{2}{9}$

130. If $f(x) = \begin{cases} \frac{e^{e/x} - e^{-e/x}}{e^{1/x} + e^{-1/x}}, & x \neq 0 \\ k, & x = 0 \end{cases}$ then

- (a) f is continuous at x, when $k = 0$
 (b) f is not continuous at $x = 0$ for any real k.
 (c) $\lim_{x \rightarrow 0} f(x)$ exist infinitely
 (d) None of these

131. $\int \cos \left\{ 2 \tan^{-1} \sqrt{\frac{1-x}{1+x}} \right\} dx$ is equal to

- (a) $\frac{1}{8}(x^2 - 1) + k$ (b) $\frac{1}{2}x^2 + k$
 (c) $\frac{1}{2}x + k$ (d) None of these

132. The equation of chord of the circle $x^2 + y^2 = 8x$ bisected at the point (4, 3) is

- (a) $x = 3$ (b) $y = 3$
 (c) $x = -3$ (d) $y = -3$

133. x and y are positive number. Let g and a be G. M. and AM of these numbers. Also let G be G. M. of $x + 1$ and $y + 1$. If G and g are roots of equation $x^2 - 5x + 6 = 0$, then

- (a) $x = 2, y = \frac{3}{4}$ (b) $x = \frac{3}{4}, y = 12$
 (c) $x = \frac{5}{2}, y = \frac{8}{5}$ (d) $x = y = 2$

134. The co-efficient of x^n in the expansion of

$$\frac{e^{7x} + e^x}{e^{3x}}$$
 is

(a) $\frac{4^{n-1} + (-2)^n}{n!}$ (b) $\frac{4^{n-1} + 2^n}{n!}$

(c) $\frac{4^n + (-2)^n}{n!}$ (d) $\frac{4^{n-1} + (-2)^{n-1}}{n!}$

135. A pair of tangents are drawn from the origin to the circle $x^2 + y^2 + 20(x + y) + 20 = 0$, then the equation of the pair of tangent are

- (a) $x^2 + y^2 - 5xy = 0$
 (b) $x^2 + y^2 + 2x + y = 0$
 (c) $x^2 + y^2 - xy + 7 = 0$
 (d) $2x^2 + 2y^2 + 5xy = 0$

136. If the sum of a certain number of terms of the A.P. 25, 22, 19, is 116. then the last term is

- (a) 0 (b) 2
 (c) 4 (d) 6

137. If 1, a and P are in A. P. and 1, g and P are in G. P., then

- (a) $1 + 2a + g^2 = 0$ (b) $1 + 2a - g^2 = 0$
 (c) $1 - 2a - g^2 = 0$ (d) $1 - 2a + g^2 = 0$

138. If $y = \sin x + e^x$, then $\frac{d^2x}{dy^2}$ is equal to

- (a) $\frac{\sin x - e^x}{(\cos x + e^x)^2}$ (b) $\frac{\sin x - e^x}{(\cos x + e^x)^3}$
 (c) $\frac{\sin x + e^x}{(\cos x - e^x)^2}$ (d) $(-\sin x + e^x)^{-1}$

139. The foci of the hyperbola $4x^2 - 9y^2 - 1 = 0$ are

- (a) $(\pm\sqrt{13}, 0)$ (b) $\left(\pm\frac{\sqrt{13}}{6}, 0 \right)$
 (c) $\left(0, \pm\frac{\sqrt{13}}{6} \right)$ (d) None of these

140. From the top of a cliff 50 m high, the angles of depression of the top and bottom of a tower are observed to be 30° and 45° . The height of tower is
 (a) 50 m (b) $50\sqrt{3}$ m
 (c) $50(\sqrt{3}-1)$ m (d) $50\left(1-\frac{\sqrt{3}}{3}\right)$ m
141. The coefficient of x^2 term in the binomial expansion of $\left(\frac{1}{3}x^{1/2} + x^{-1/4}\right)^{10}$ is :
 (a) $\frac{70}{243}$ (b) $\frac{60}{423}$
 (c) $\frac{50}{13}$ (d) none of these
142. The value of λ , for which the circle $x^2 + y^2 + 2\lambda x + 6y + 1 = 0$ intersects the circle $x^2 + y^2 + 4x + 2y = 0$ orthogonally, is
 (a) $11/8$ (b) -1
 (c) $-5/4$ (d) $5/2$
143. The value of $\left[\overline{a} + \overline{b} \overline{b} + \overline{c} \overline{c} + \overline{a}\right]$ is
 (a) $2\left[\overline{a} \overline{b} \overline{c}\right]$ (b) $\left[\overline{a} \overline{b} \overline{c}\right]$
 (c) 1 (d) None of these
144. If $f(x) = (a - x^n)^{1/n}$, where $a > 0$ and $n \in \mathbb{N}$, then $f \circ f(x)$ is equal to :
 (a) a (b) x
 (c) x^n (d) a^n
145. Sum of n terms of the series $8 + 88 + 888 + \dots$ equals
 (a) $\frac{8}{81} [10^{n+1} - 9n - 10]$
 (b) $\frac{8}{81} [10^n - 9n - 10]$
 (c) $\frac{8}{81} [10^{n+1} - 9n + 10]$
 (d) None of these
146. The modulus of the complex number z such that $|z + 3 - i| = 1$ and $\arg(z) = \pi$ is equal to
 (a) 3 (b) 2
 (c) 9 (d) 4
147. Bag P contains 6 red and 4 blue balls and bag Q contains 5 red and 6 blue balls. A ball is transferred from bag P to bag Q and then a ball is drawn from bag Q. What is the probability that the ball drawn is blue?
 (a) $\frac{7}{15}$ (b) $\frac{8}{15}$
 (c) $\frac{4}{19}$ (d) $\frac{8}{19}$
148. The number of 4-digit numbers that can be formed with the digits 1, 2, 3, 4 and 5 in which at least 2 digits are identical, is
 (a) 505 (b) $4^5 - 5!$
 (c) 600 (d) None of these
149. Consider the system of linear equations;
 $x_1 + 2x_2 + x_3 = 3$
 $2x_1 + 3x_2 + x_3 = 3$
 $3x_1 + 5x_2 + 2x_3 = 1$
 The system has
 (a) exactly 3 solutions
 (b) a unique solution
 (c) no solution
 (d) infinitesolutions
150. What is the value of y so that the line through (3, y) and (2, 7) is parallel to the line through (-1, 4) and (0, 6)?
 (a) 6 (b) 7
 (c) 5 (d) 9

SOLUTIONS

PART - I : PHYSICS

- (c) The charged sphere is a conductor. Therefore the field inside is zero and outside it is proportional to $1/r^2$.
- (c) The direction of propagation of electromagnetic wave is perpendicular to the variation of electric field \vec{E} as well as to the magnetic field \vec{B} .
- (b) Young's modulus of wire does not vary with dimension of wire. It is a constant quantity.
- (d) Redraw the given circuit,

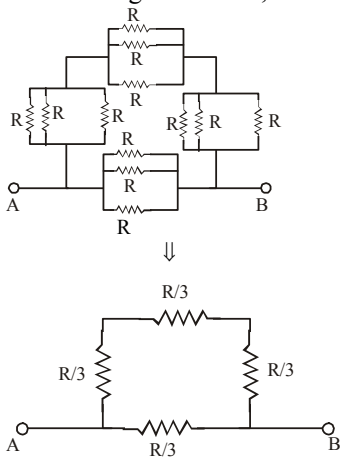

$$R_{\text{net}} \text{ between AB} = \frac{\frac{3R}{3} \times \frac{R}{3}}{\frac{3R}{3} + \frac{R}{3}} = \frac{R^2}{4R}$$

where, $R = 16 \Omega$

$$R_{\text{net}} = 4 \Omega$$

- (c) According to Kepler's law of planetary motion, $T^2 \propto R^3$

$$\therefore T_2 = T_1 \left(\frac{R_2}{R_1} \right)^{3/2}$$

$$= 5 \times \left[\frac{4R}{R} \right]^{3/2} = 40 \text{ hours}$$

$$6. \quad (d) \quad f' = f \left(\frac{v + v_o}{v - v_s} \right)$$

Here, $f = 600 \text{ Hz}$, $v_o = 15 \text{ m/s}$

$v_s = 20 \text{ m/s}$, $v = 340 \text{ m/s}$

$$f' = 600 \times \left[\frac{340 + 15}{340 - 20} \right]$$

$$\therefore f' = 600 \left(\frac{355}{320} \right) \approx 666 \text{ Hz}$$

- (c) Concave mirror is used as a shaving mirror.

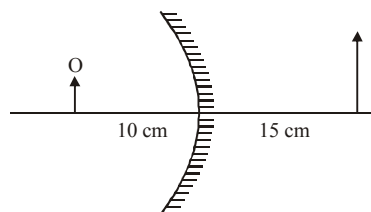

From question : $v = 15 \text{ cm}$, $u = -10 \text{ cm}$

Radius of curvature, $R = 2f = ?$

Using mirror formula, $\frac{1}{v} + \frac{1}{u} = \frac{1}{f}$

$$\frac{1}{15} + \frac{1}{(-10)} = \frac{1}{f} \Rightarrow f = -30 \text{ cm}$$

Therefore radius of curvature,

$$R = 2f = -60 \text{ cm}$$

- (c) From free body diagram, For block to remain stationary,

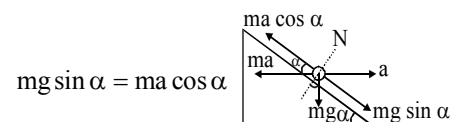

$$mg \sin \alpha = ma \cos \alpha$$

$$\Rightarrow a = g \tan \alpha$$

- (a) On increasing the temperature, angle of contact decreases.

- (b) Forward bias opposes the potential barrier and if the applied voltage is more than knee voltage it cancels the potential barrier.

11. (c) In multiplication or division the final result should return as many significant figures as there are in the original number with the least significant figures.

(Rounding off to three significant digits)

12. (b) Let 'n' be the degree of freedom

$$C_v = \frac{n}{2}R$$

$$\text{also, } C_p - C_v = R$$

$$C_p = C_v + R$$

$$C_p = \frac{n}{2}R + R$$

$$C_p = \left(\frac{n}{2} + 1\right)R$$

so,

$$\gamma = \frac{C_p}{C_v} = \frac{\left(\frac{n}{2} + 1\right)R}{\left(\frac{n}{2}\right)R} = \left(1 + \frac{2}{n}\right)$$

13. (c) Since range on horizontal plane is

$$R = \frac{u^2 \sin 2\theta}{g}$$

so it is maximum when, $\sin 2\theta = 1$

$$\theta = \frac{\pi}{4}$$

14. (c) Mass = 150 gm = $\frac{150}{1000}$ kg

Force = Mass \times acceleration

$$= \frac{150}{1000} \times 20 \text{ N} = 3 \text{ N}$$

Impulsive force = $F \cdot \Delta t = 3 \times 0.1 = 0.3 \text{ N}$

15. (b) Given, $d = 10 \text{ m}$

$$\theta = 30^\circ$$

$$\mu = 0.5$$

$$F = \sqrt{3} \text{ kN} = \sqrt{3} \times 10^3 \text{ N}$$

$$W = F_s d \cos \theta$$

Where,

$$F_s = \mu F$$

$$F_s = 0.5 \times \sqrt{3} \text{ kN}$$

$$F_s = 0.866 \text{ kN}$$

$$F_s = 866 \text{ N}$$

$$\text{So, } W = 866 \times 10 \times \cos 30^\circ$$

$$W = \frac{866 \times 10 \times \sqrt{3}}{2}$$

$$W = 7499.56 \text{ J}$$

$$W \approx 7.5 \text{ kJ}$$

16. (a) $W = \vec{F} \cdot \vec{s} = (2\hat{i} + 3\hat{j} + 4\hat{k}) \cdot (3\hat{i} + 4\hat{j} + 5\hat{k})$
 $= 2 \times 3 + 3 \times 4 + 4 \times 5 = 38 \text{ J}$

$$P = \frac{W}{t} = \frac{38}{4} = 9.5 \text{ W.}$$

17. (d) $v_e = \sqrt{\frac{2GM}{R}}$

$$\text{and, } v'_e = \sqrt{\frac{2GM}{(R+h)}} = \sqrt{\frac{2GM}{(R+R)}} = \frac{v_e}{\sqrt{2}}$$

$$\therefore f = \frac{1}{\sqrt{2}}$$

18. (b) $\frac{dA}{dt} = \frac{L}{2m} = \text{Constant}$

19. (a) According to Bernoulli's theorem

$$P_1 + \frac{1}{2} \rho v_1^2 = P_2 + \frac{1}{2} \rho v_2^2 \quad \dots(i)$$

According to the condition,

$$P_1 - P_2 = 3 \times 10^5, \frac{A_1}{A_2} = 5$$

From equation of continuity,

$$A_1 v_1 = A_2 v_2$$

$$\text{so, } \frac{A_1}{A_2} = \frac{v_2}{v_1} = 5 \Rightarrow v_2 = 5v_1$$

From equation (i)

$$P_1 - P_2 = \frac{1}{2} \rho (v_2^2 - v_1^2)$$

$$\text{or } 3 \times 10^5 = \frac{1}{2} \times 1000 (25v_1^2 - v_1^2)$$

$$\Rightarrow 600 = 24v_1 \Rightarrow v_1^2 = 25$$

$$\therefore v_1 = 5 \text{ m/s}$$

20. (c) Work done = Area under curve ACBDA

21. (a)

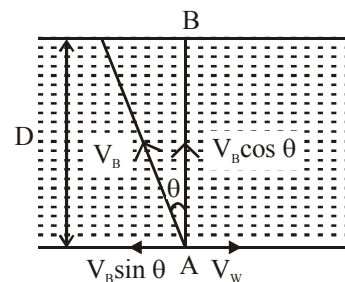

From figure, $V_B \sin \theta = V_W$

$$\sin \theta = \frac{V_w}{V_B} = \frac{1}{2} \Rightarrow \theta = 30^\circ \quad [\because V_B = 2V_w]$$

Time taken to cross the river.

$$t = \frac{D}{V_B \cos \theta} = \frac{D}{V_B \cos 30^\circ} = \frac{2D}{V_B \sqrt{3}}$$

22. (a) The two springs are in parallel.

\therefore Effective spring constant,

$$k = k_1 + k_2$$

Now, frequency of oscillation is given by

$$f = \frac{1}{2p} \sqrt{\frac{k}{m}}$$

or,
$$f = \frac{1}{2p} \sqrt{\frac{k_1 + k_2}{m}} \quad \dots(i)$$

When both k_1 and k_2 are made four times their original values, the new frequency is given by

$$f' = \frac{1}{2p} \sqrt{\frac{4k_1 + 4k_2}{m}}$$

$$f' = \frac{1}{2p} \sqrt{\frac{4(k_1 + k_2)}{m}} = 2 \left(\frac{1}{2p} \sqrt{\frac{k_1 + k_2}{m}} \right) = 2f$$

23. (b) Drift velocity,

$$v_d = \frac{i}{neA} = \frac{J}{ne} = \frac{\sigma E}{ne} = \frac{E}{\rho ne} = \frac{V}{\rho ne}$$

so $v_d \propto V$

24. (b) Amplitude of a damped oscillator

$$A = A_0 e^{-bt/2m}$$

Case 1 :-

$$\text{When } t = 2 \text{ s, } A = \frac{A_0}{3}$$

$$\therefore \frac{A_0}{3} = A_0 e^{-2b/2m} \Rightarrow \frac{1}{3} = e^{-b/m} \dots (i)$$

Case 2 :-

$$\text{When } t = 6 \text{ s, } A = \frac{A_0}{n}$$

$$\therefore \frac{A_0}{n} = A_0 e^{-6b/2m} \Rightarrow \frac{1}{n} = (e^{-b/m})^3 \dots (ii)$$

From (i) and (ii)

$$\frac{1}{n} = \left(\frac{1}{3} \right)^3 \Rightarrow \therefore n = 3^3$$

25. (d) Angular speed of electron in the n th orbit of Bohr H-atom is inversely proportional to n^3

$$\omega_n \propto \frac{1}{n^3}$$

26. (a) $C =$ equivalent capacitance

$$\therefore \frac{1}{C} = \frac{1}{2} + \frac{1}{3} + \frac{1}{6} \Rightarrow C = 1 \mu\text{F}$$

Charge on each capacitor in series circuit will be same.

$$\therefore q = CV = (1 \times 10^{-6}) \times 10 = 10 \mu\text{C}$$

\therefore Charge across $3 \mu\text{F}$ capacitor will be $10 \mu\text{C}$.

27. (a)
$$\frac{E_1}{E_2} = \frac{\sigma(T_1^4 - T_0^4)}{\sigma(T_2^4 - T_0^4)} = \frac{(600)^4 - (300)^4}{(500)^4 - (300)^4}$$

28. (c)

29. (a) For open pipe, $n_1 = \frac{v}{2\ell}$, where n_1 is the

fundamental frequency of open pipe.

length of open pipe is,

$$\therefore \ell = \frac{v}{2n} = \frac{330}{2 \times 300} = \frac{11}{20}$$

Ist overtone of open pipe, $n_2 = 2n_1 = 2 \left(\frac{v}{2\ell} \right)$

Ist overtone of closed pipe,

$$n_3 = 3n_1 = 3 \left(\frac{v}{4\ell'} \right)$$

where, ℓ' = length of closed pipe

As freq. of 1st overtone of open pipe = freq. of 1st overtone of closed pipe

$$\therefore 2 \frac{v}{2\ell} = 3 \frac{v}{4\ell'} \Rightarrow \ell' = \frac{3\ell}{4} = \frac{3}{4} \times \frac{11}{20} = 41.25 \text{ cm}$$

30. (d) $\beta = \frac{D\lambda}{d}$ and $\beta' = \frac{(2D)\lambda}{(d/2)} = 4\beta$

Thus the fringe width becomes four times.

31. (a) As we know, τ is change in angular momentum.

$$\text{so, } \tau = \frac{20}{3} \text{ SI units}$$

32. (a) Let q and q' be the charges on spheres of radii x and $2x$ respectively.

$$\text{Given, } q + q' = Q \quad \dots(i)$$

Surface charge densities are

$$\sigma = \frac{q}{4\pi x^2} \text{ and } \sigma' = \frac{q'}{4\pi (2x)^2}$$

Given, $\sigma = \sigma'$

$$\therefore \frac{q}{4\pi x^2} = \frac{q'}{4\pi(2x)^2}$$

$$q' = 4q$$

From eq. (i), $q' = Q - q$ or, $4q = Q - q$

$$\text{or, } Q = 5q \quad \dots(\text{ii})$$

$$\therefore q' = Q - q = Q - \frac{Q}{5} = \frac{4Q}{5}$$

33. (d) $L = 2 \text{ H}, E = 5 \text{ volts}, R = 1 \Omega$

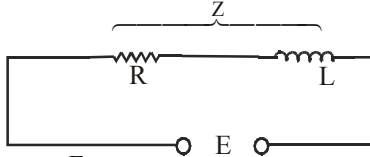

$$I = \frac{E}{Z}$$

$$Z = \sqrt{R^2 + (\omega L)^2}$$

$$I = \frac{5}{\sqrt{R^2 + (\omega L)^2}} = \frac{5}{\sqrt{1 + 4\pi^2 \times 50^2 \times 4}}$$

$$= \frac{5}{\sqrt{1 + (200\pi)^2}} \approx \frac{5}{200\pi}$$

$$\text{Energy in inductor} = \frac{1}{2} LI^2$$

$$= \frac{1}{2} \times 2 \times \left(\frac{5 \times 5}{200 \times 200\pi^2} \right)$$

$$= 6.33 \times 10^{-5} \text{ joules}$$

34. (b) $F = Bi\ell = 2 \times 1.2 \times 0.5 = 1.2 \text{ N}$

35. (b) Distance between two cars leaving from the station A is,

$$d = \frac{1}{6} \times 60 = 10 \text{ km}$$

Man meets the first car after time,

$$t_1 = \frac{60}{60 + 60} = \frac{1}{2} \text{ h}$$

He will meet the next car after time,

$$t_2 = \frac{10}{60 + 60} = \frac{1}{12} \text{ h}$$

In the remaining half an hour, the number of cars he will meet again is, $n = \frac{1/2}{1/12} = 6$

\therefore Total number of cars would be met on route will be 7.

36. (b) From $v = r\omega$, linear velocities (v) for particles at different distances (r) from the axis of rotation are different.

37. (a) For an SHM, the acceleration $a = -\omega^2 x$

where, ω is a constant $= \frac{2\pi}{T}$

$$a = -\frac{4\pi^2}{T^2} \cdot x \Rightarrow \frac{aT}{x} \Rightarrow -\frac{4\pi^2}{T}$$

The period of oscillation T is a constant.

$\therefore \frac{aT}{x}$ is a constant.

38. (a) As the inward magnetic field increases, its flux also increases into the page and so induced current in bigger loop will be anticlockwise. i.e., from D to C in bigger loop and then from B to A in smaller loop.

39. (a) Since A moves twice the distance moved by B.

If acceleration of B is 'a', then acceleration of A is '2a'.

$$T' - (T + T) = 0 \text{ (since pulley is massless)}$$

$$\Rightarrow T' = 2T \quad \dots(\text{i})$$

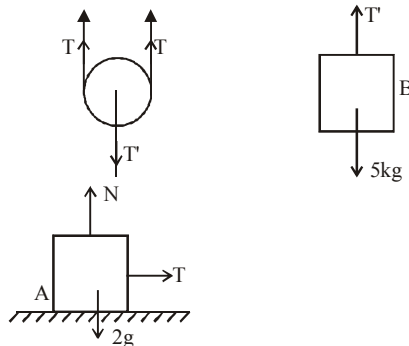

For 5 kg block

$$5g - T' = 5a$$

for 2 kg block

$$\Rightarrow 5g - 2T = 5a$$

$$T = 2 \times (2a) = 4a$$

From equations (ii) and (iii),

$$5g - (2 \times 4a) = 5a$$

$$5g - 8a = 5a$$

$$5g = 13a$$

$$a = \frac{5g}{13}$$

$$a_A = 2a = \frac{10g}{13}; \quad a_B = a = \frac{5g}{13}$$

40. (a) Isotones means equal number of neutrons i.e., $(A - Z) = 74 - 34 = 71 - 31 = 40$

PART - II : CHEMISTRY

41. (a) As per Arrhenius equation ($k = Ae^{-E_a/RT}$), the rate constant increases exponentially with temperature.

42. (c) Mass of O_2 absorbed per gram of adsorbent = $\frac{3.6}{1.2} = 3$
 No. of moles of O_2 absorbed per gram of adsorbent = $\frac{3}{32}$
 Volume of O_2 absorbed per gram of adsorbent
 $PV = nRT$
 $V = \frac{nRT}{P}$
 $= \frac{3}{32} \times \frac{0.0821 \times 273}{1} = 2.1$

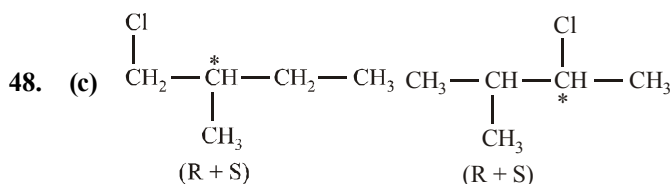

Four monochloro derivatives are chiral.

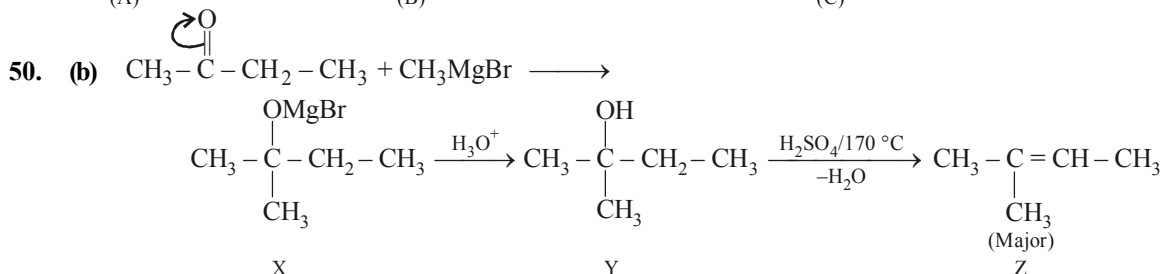
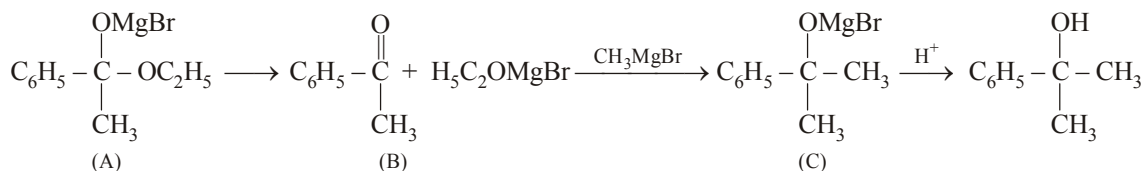

43. (b)

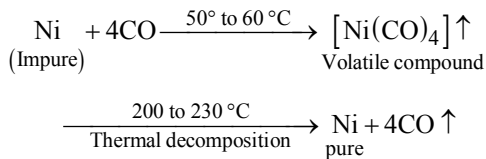

44. (a) $3\text{Cl}_2 + 2\text{NaI} \rightarrow 2\text{NaCl} + \text{I}_2$
 I_2 gives violet colouration in CHCl_3 .
 $5\text{Cl}_2 + 6\text{H}_2\text{O} + \text{I}_2 \rightarrow \text{HIO}_3 + 10\text{HCl}$
 Colourless

45. (d) Clathrate formation involves dipole-induced dipole interaction.

46. (d) $\text{Eu} (63) = [\text{Xe}] 4f^7 6s^2$
 $\text{Gd} (64) = [\text{Xe}] 4f^7 5d^1 6s^2$
 $\text{Tb} (65) = [\text{Xe}] 4f^9 6s^2$

47. (a) As positive charge on the central metal atom increases, the less readily the metal can donate electron density into the π^* orbitals of CO ligand (donation of electron density into π^* orbitals of CO result in weakening of C-O bond). Hence, the C-O bond would be strongest in $[\text{Mn}(\text{CO})_6]^+$.

51. (b) In compound (b), the lone pair of nitrogen is not involved in resonance therefore it is the strongest base.

52. (c) Sucrose, being a non-reducing sugar, does not reduce Benedict's solution. Remember that fructose has an α -hydroxy ketonic group, which is also reducing group (different from ordinary ketonic group)

53. (c) Zn^{+2} present in alternate tetrahedral void

$$= \frac{1}{2} \times 8 = 4$$

S^{2-} present in $ccp = 4$

$\therefore Zn_4S_4 = ZnS$ i.e., AB type compound.

54. (d) Glycine in alkaline solution exists as anion and migrates to anode.

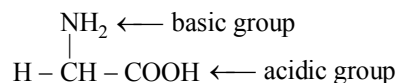

Due to internal proton transfer of H^+ from the $-COOH$ group to the $-NH_2$, the amino acid exists as an ion with both a negative charge and a positive charge, called a Zwitter ion

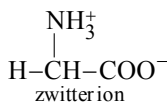

Adding an alkali to glycine

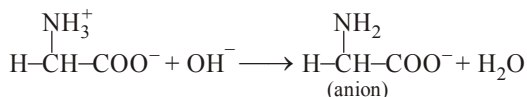

Now, during electrophoresis, glycine moves towards anode.

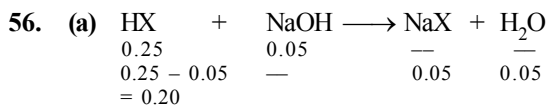
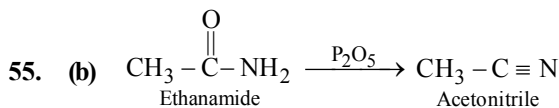

$$K_a = \frac{[\text{H}^+][\text{X}^-]}{[\text{HX}]}$$

$$10^{-5} = \frac{[\text{H}^+]0.05}{0.20}$$

$$\frac{0.20}{0.05} \times 10^{-5} = [\text{H}^+]$$

$$4 \times 10^{-5} \text{ M} = [\text{H}^+]$$

57. (c) $\text{Pt} | \text{H}_2 (640 \text{ mm}) | \text{HCl} | \text{H}_2 (510 \text{ mm}) | \text{Pt}$

$$E_{\text{cell}}^\circ = 0$$

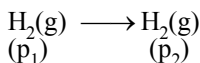
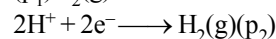
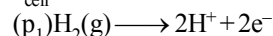

$$E_{\text{cell}} = E_{\text{cell}}^\circ - \frac{0.0591}{n} \log \frac{\text{p}_2}{\text{p}_1}$$

$$= 0 - \frac{0.0591}{2} \log \frac{510}{640}$$

$$= 2.91 \times 10^{-3} \text{ V}$$

58. (a)

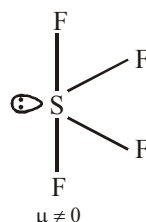
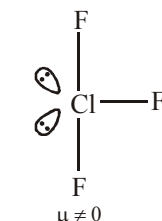
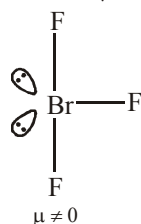
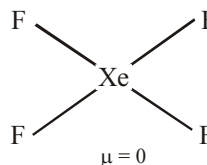

XeF_4 has zero net dipole moment

59. (a) Boron has the highest ionisation enthalpy amongst the following.

Ionisation enthalpy decreases down the group and increases across the period.

60. (a) Element with atomic number 7 has the smallest size and highest ionization enthalpy
Nitrogen – Atomic Number 7



N has a stable half-filled electronic configuration therefore it is difficult to remove electron and hence it has a high ionization enthalpy.

61. (a) Except dacron all are additive polymers. Terephthalic acid condenses with ethylene glycol to give dacron.

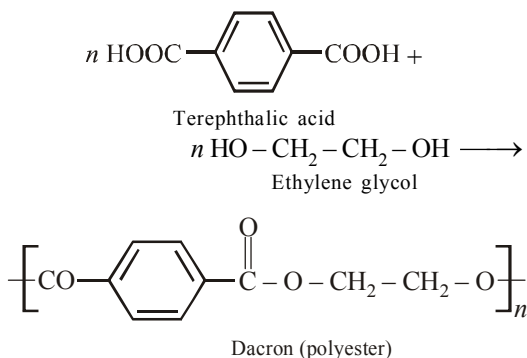

62. (a) Phenelzine is an antidepressant, while others are antacids.

63. (b) 1 molal solution means 1 mole of solute dissolved in 1000 g solvent.

$$\therefore n_{\text{solute}} = 1 \quad w_{\text{solvent}} = 1000 \text{ g}$$

$$\therefore n_{\text{solvent}} = \frac{1000}{18} = 55.56$$

$$x_{\text{solute}} = \frac{1}{1 + 55.56} = 0.0177$$

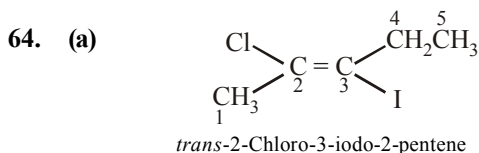

65. (a) Stability of carbocation \propto no. of α -H present on carbocation.

66. (a) Only Lindlar's catalyst converts alkyne to alkene (*cis* addition) and alkenes with Baeyer's reagent give *cis* glycols.

67. (b) Lower oxidation state become more stable on moving down the group
 $\text{Al} < \text{Ga} < \text{In} < \text{Tl}$

68. (a) $\text{Be}(\text{OH})_2$ is amphoteric while $\text{Ca}(\text{OH})_2$, $\text{Sr}(\text{OH})_2$ and $\text{Ba}(\text{OH})_2$ are all basic.

69. (a) $\text{H}_2\text{O}_2 + 2\text{KI} \longrightarrow \text{I}_2$, O.S. of $\text{I}^- (-1)$ changes to I_2 (Zero) There is increase in oxidation number, hence oxidation.

70. (d) The balanced equation is

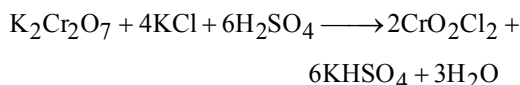

71. (a) $\frac{[\text{B}]}{[\text{A}]} = 2$, $\frac{[\text{C}]}{[\text{B}]} = 4$ and $\left[\frac{\text{D}}{\text{C}}\right] = 6$

Multiply the three equations,

$$2 \times 4 \times 6 = \frac{[\text{D}]}{[\text{A}]} = K_c$$

72. (d) $\Delta G = \Delta H - T\Delta S = +ve$
for spontaneous change, $\Delta H < 0$, $\Delta S > 0$
for non-spontaneous change, $\Delta H > 0$, $\Delta S < 0$

73. (b) $\frac{r_1}{r_2} = \sqrt{\frac{d_2}{d_1}} = \sqrt{\frac{16}{1}} = 4 : 1$

74. (a) $2\text{PCl}_5 \rightleftharpoons \text{PCl}_4^+ + \text{PCl}_6^-$
 $sp^3d \quad \quad \quad sp^3 \quad \quad \quad sp^3d^2$

75. (a) Isoelectronic species have same no. of electrons.

Ions	O^{2-}	F^-	Na^+
Mg^{2+}			
8 + 2	9 + 1	11 - 1	12 - 2
No. of $e^- = 10$	10	10	10
$\therefore \text{O}^{2-}, \text{F}^-, \text{Na}^+, \text{Mg}^{2+}$ are isoelectronic			

76. (c) This is Avogadro's hypothesis. According to this, equal volume of all gases contain equal no. of molecules under similar condition of temperature and pressure.

77. (a) Eq. of A = Eq. of B

$$\frac{m_A}{E_A} = \frac{m_B}{E_B}; E_A = \frac{m_A}{m_B} \times E_B$$

78. (c) For $4p$ electron $n = 4$, $l = 1$, $m = -1, 0, +1$ and $s = +\frac{1}{2}$ or $-\frac{1}{2}$

79. (c) $l = 2$ represent d orbital for which

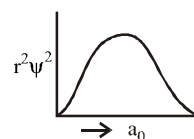

80. (a) B_2 is paramagnetic due to the presence of unpaired electron in $\pi 2p_x = \pi 2p_y$ orbital.

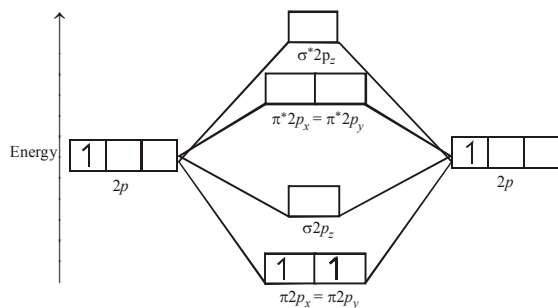

M.O diagram for B_2 molecule

PART - III (A): ENGLISH PROFICIENCY

81. (a) The word **Garrulous** (Adjective) means : talkative; talking a lot.
82. (b) The word **Tinsel** (Noun/Adjective) means : strips of shiny material like metal used as decorations.
83. (a) The word **Labyrinth** (Noun) means : a place that has many confusing paths or passage. The correct synonym will be 'meandering' which means, 'to have a lot of curves on a path'.
84. (b) Knack means a clever way of doing something.
85. (d) Pernicious means highly injurious or destructive.
86. (d) Opulence means wealthy.
87. (a) In good friendships, we receive as much as we give.
88. (b) Empathy means the ability to show and understand the feelings of others.
89. (c) A strong friendship helps us gain acceptance and tolerance.
90. (d) The very first line of the passage states that friendships and relationships grow when they are nurtured just like nurturing a plant.
91. (a) **Dependent on** = needing somebody / something in order to survive or be successful; affected or decided by something.
92. (b) **Take your leave** = to say good bye.
93. (b) Here, indefinite article i.e., 'about a plane crash' should be used. No particular incident is evident here.
94. (b) 'With a View to' should be followed by gerund i.e., surveying.
95. (a) Here, time period is given. Hence, Past Perfect Continuous i.e., 'It had been lying'should be used.

PART - III (B) : LOGICAL REASONING

96. (b) 97. (c) 98. (d)
99. (c) Medicine is given to patient. Similarly, Education is given to student.
100. (d)
-
- The diagram shows a sequence of prime numbers: A 3 E, F 5 J, K 7 O, P 11 T. Above each number is a '+5' with an arrow pointing down to the next number. Below each number is a '+5' with an arrow pointing up to the next number. A long arrow at the bottom points from the first number to the last, labeled 'Consecutive Prime number'.
101. (a) Except 5, all numbers are perfect square numbers.
102. (a) As,
 TIRED = $20 + 9 + 18 + 5 + 4 = 56$
 BRAIN = $2 + 18 + 1 + 9 + 14 = 44$
 Similarly,
 LAZY = $12 + 1 + 26 + 25 = 64$.
103. (b) $8 \times 8 \times 88 = 5632$
 $7 \times 7 \times 77 = 3773$
 Similarly, $6 \times 6 \times ? = 3132$
 $\therefore ? = \frac{3132}{6 \times 6} = 87$
104. (b)
-
- The diagram shows two overlapping circles. The left circle is labeled 'Political Party' and the right circle is labeled 'Youth club'. An arrow points from the intersection of the two circles to the word 'Youths' above it.
105. (d) Mohan is son of Ram Lal and uncle of Ram and Rekha. Mithun is uncle of Sharat who is son of Rekha. Rekha is niece of Mohan. Therefore, Mithun is brother of Rekha's husband.

PART - IV : MATHEMATICS

106. (c) Given line is $x \cos \alpha + y \sin \alpha = P$ (1)

Any tangent to the ellipse is

$$\frac{x \cos \theta}{a} + \frac{y \sin \theta}{b} = 1 \quad \dots(2)$$

Comparing (1) and (2)

$$\frac{\cos \theta}{a \cos \alpha} = \frac{\sin \theta}{b \sin \alpha} = \frac{1}{P}$$

$$\Rightarrow \cos \theta = \frac{a \cos \alpha}{P} \text{ and } \sin \theta = \frac{b \sin \alpha}{P}$$

Eliminate θ , $\cos^2 \theta + \sin^2 \theta$

$$= \frac{a^2 \cos^2 \alpha}{P^2} + \frac{b^2 \sin^2 \alpha}{P^2},$$

$$\text{or } a^2 \cos^2 \alpha + b^2 \sin^2 \alpha = P^2$$

107. (c) As $a_1, a_2, a_3, \dots, a_n$, are in A.P. we get,
 $a_2 - a_1 = a_3 - a_2 = \dots = a_n - a_{n-1} = d$ (say)

$$\text{Now, } \frac{1}{\sqrt{a_1} + \sqrt{a_2}} = \frac{\sqrt{a_1} - \sqrt{a_2}}{a_1 - a_2} = \frac{\sqrt{a_1} - \sqrt{a_2}}{-d}$$

Similarly,

$$\frac{1}{\sqrt{a_2} + \sqrt{a_3}} = \frac{\sqrt{a_2} - \sqrt{a_3}}{-d}, \dots, \frac{1}{\sqrt{a_{n-1}} + \sqrt{a_n}} = \frac{\sqrt{a_{n-1}} - \sqrt{a_n}}{-d}$$

$$\therefore \frac{1}{\sqrt{a_1} + \sqrt{a_2}} + \frac{1}{\sqrt{a_2} + \sqrt{a_3}} + \dots + \frac{1}{\sqrt{a_{n-1}} + \sqrt{a_n}} = \frac{\sqrt{a_1} - \sqrt{a_2} + \sqrt{a_2} - \sqrt{a_3} + \dots + \sqrt{a_{n-1}} - \sqrt{a_n}}{-d}$$

$$= \frac{\sqrt{a_1} - \sqrt{a_n}}{-d} = -\frac{1}{d} \left[\frac{a_1 - a_n}{\sqrt{a_1} + \sqrt{a_n}} \right]$$

$$= -\frac{1}{d} \left[\frac{a_1 - \{a_1 + (n-1)d\}}{\sqrt{a_1} + \sqrt{a_n}} \right]$$

[formula for n^{th} term]

$$= -\frac{1}{d} \left[\frac{-(n-1)d}{\sqrt{a_1} + \sqrt{a_n}} \right] = \frac{n-1}{\sqrt{a_1} + \sqrt{a_n}}$$

108. (b) Given differential equation is:
 $x \cos x \frac{dy}{dx} + y(x \sin x + \cos x) = 1$
 Dividing both the sides by $x \cos x$,

$$\Rightarrow \frac{dy}{dx} + \frac{y \sin x}{x \cos x} + \frac{y \cos x}{x \cos x} = \frac{1}{x \cos x}$$

$$\Rightarrow \frac{dy}{dx} + y \tan x + \frac{y}{x} = \frac{1}{x \cos x}$$

$$\Rightarrow \frac{dy}{dx} + \left(\tan x + \frac{1}{x} \right) y = \frac{\sec x}{x}$$

which is of the form $\frac{dy}{dx} + Py = Q$

$$\text{Here, } P = \tan x + \frac{1}{x} \text{ and } Q = \frac{\sec x}{x}$$

$$\text{Integrating factor} = e^{\int P dx} = e^{\int \tan x + \frac{1}{x} dx} = e^{(\log \sec x + \log x)} = e^{\log(\sec x \cdot x)} = x \sec x$$

109. (c) Equation of the first line L_1 is

$$\frac{x-1}{2} = \frac{y-2}{3} = \frac{z-3}{4} \text{ and that of the second line}$$

$$L_2 \text{ is } \frac{x-4}{5} = \frac{y-1}{2} = \frac{z-0}{1} \text{ Clearly, these lines are}$$

not parallel (the ratios of D.R. are not equal). Any point P on the first line is $(1+2\lambda, 2+3\lambda, 3+4\lambda)$ and any point Q on the second line is $(4+5\mu, 1+2\mu, \mu)$. If these two points P and Q are identical then.

$$1+2\lambda = 4+5\mu \quad \dots(1)$$

$$2+3\lambda = 1+2\mu \quad \dots(2)$$

$$3+4\lambda = \mu \quad \dots(3)$$

From (2) and (3), we get $\lambda = \mu = -1$, which also satisfies (1). Thus the two lines L_1 and L_2 ; intersect and the coordinates of the point of intersection are $(-1, -1, -1)$.

110. (c) We have $y - x \frac{dy}{dx} = a \left(y^2 + \frac{dy}{dx} \right)$

$$\Rightarrow y dx - x dy = ay^2 dx + a dy$$

$$\Rightarrow y(1-ay) dx = (x+a) dy$$

$$\Rightarrow \frac{dx}{x+a} - \frac{dy}{y(1-ay)} = 0$$

Integrating, we get

$$\log(x+a) - \log y + \log(1-ay) = \log C$$

or $\log \frac{(a+x)(1-ay)}{y} = \log C$ i.e. $(x+a)(1-ay) = Cy$

Since the curve passes through $\left(a, -\frac{1}{a}\right)$

$$\therefore 2a \times (1+1) = -\frac{C}{a} \text{ i.e. } C = -4a^2$$

So, $(x+a)(1-ay) = -4a^2y$

111. (c)

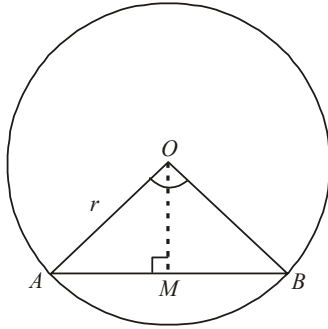

Equation of given circle is $x^2 + y^2 = 4$

Its centre, $O = (0, 0)$ and radius, $r = 2$

Draw $OM \perp AB$

Clearly M is the mid-point of AB which subtends a right angle at O.

In $\triangle AOB$, $OA = OB$ radius

$$\therefore \angle A = \angle B = \frac{\pi}{4}$$

and in $\triangle OMA$, $\sin A = \frac{OM}{OA}$

$$\sin \frac{\pi}{4} = \frac{OM}{2}$$

$$\Rightarrow \frac{1}{\sqrt{2}} = \frac{OM}{2}$$

$$\Rightarrow OM = \sqrt{2} \quad \dots(1)$$

Let $M = (x, y)$ then $OM = \sqrt{x^2 + y^2} \quad \dots(2)$

From (1) and (2), $x^2 + y^2 = 2$

This is the required equation of locus.

112. (c) $I = \int_1^2 [x^2] dx - \int_1^2 [x]^2 dx$

$$= \int_1^{\sqrt{2}} dx + \int_{\sqrt{2}}^{\sqrt{3}} 2 dx + \int_{\sqrt{3}}^2 3 dx - \int_1^2 1 dx$$

$$= 4 - \sqrt{2} - \sqrt{3}$$

113. (c) $\frac{1 + \sin A - \cos A}{1 + \sin A + \cos A}$

$$= \frac{2 \sin^2 \frac{A}{2} + 2 \sin \frac{A}{2} \cos \frac{A}{2}}{2 \cos^2 \frac{A}{2} + 2 \sin \frac{A}{2} \cos \frac{A}{2}}$$

$$= \frac{2 \sin \frac{A}{2} \left(\sin \frac{A}{2} + \cos \frac{A}{2} \right)}{2 \cos \frac{A}{2} \left(\cos \frac{A}{2} + \sin \frac{A}{2} \right)} = \tan \frac{A}{2}$$

114. (c) Given $x\sqrt{1+y} + y\sqrt{1+x} = 0$

$$\Rightarrow x\sqrt{1+y} = -y\sqrt{1+x}$$

Squaring both sides, we get

$$x^2(1+y) = y^2(1+x)$$

$$\Rightarrow x^2 - y^2 + x^2y - xy^2 = 0 \Rightarrow (x-y)(x+y+xy) = 0$$

$$\Rightarrow y = x \text{ or } y(1+x) = -x \Rightarrow y = x \text{ or } y = -\frac{x}{1+x}$$

$$\Rightarrow \frac{dy}{dx} = \frac{-(1+x) \cdot 1 + x \cdot 1}{(1+x)^2} = \frac{-1}{(1+x)^2}$$

115. (b) Given: $f(x) = 3x^4 + 4x^3 - 12x^2 + 12$
Differentiating with respect to x, we get
 $f'(x) = 12x^3 + 12x^2 - 24x$

For $f(x)$ to be increasing

$$f'(x) > 0 \Rightarrow 12x^3 + 12x^2 - 24x > 0$$

$$\Rightarrow 12x(x^2 + x - 2) > 0$$

$$\Rightarrow 12x(x-1)(x+2) > 0$$

$$\Rightarrow x(x-1)(x+2) > 0$$

$$\Rightarrow -2 < x < 0 \text{ or } x > 1$$

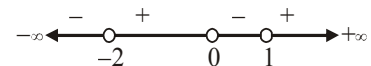

It means $x \in (-2, 0) \cup (1, \infty)$.

Hence $f(x)$ is increasing in $(-2, 0)$ and $(1, \infty)$

116. (c) Consider $\frac{x}{2} + \frac{y}{4} \geq 1$, $\frac{x}{3} + \frac{y}{2} \leq 1$,

$x, y \geq 0$ convert them into equation and solve them and draw the graph of these equations

we get

$$y = 1 \text{ and } x = 3/2$$

117. (b) Here, $a = 2\hat{i} + 5\hat{j} - 3\hat{k}$, $N = 6\hat{i} - 3\hat{j} + 2\hat{k}$
and $d = 4$.

Therefore, the distance of the point $(2, 5, -3)$ from the given plane is

$$\frac{|(2\hat{i} + 5\hat{j} - 3\hat{k}) \cdot (6\hat{i} - 3\hat{j} + 2\hat{k}) - 4|}{|6\hat{i} - 3\hat{j} + 2\hat{k}|}$$

$$= \frac{|12 - 15 - 6 - 4|}{\sqrt{36 + 9 + 4}} = \frac{13}{7} \left(\because \text{distance} = \left| \frac{\mathbf{a} \cdot \mathbf{N} - d}{N} \right| \right)$$

118. (a) $I = \int_0^{\frac{\pi}{2}} \log(\tan x) dx = \int_0^{\frac{\pi}{2}} \log \left\{ \tan \left(\frac{\pi}{2} - x \right) \right\} dx$

$$= \int_0^{\frac{\pi}{2}} \log(\cot x) dx$$

$$\therefore 2I = \int_0^{\frac{\pi}{2}} \log(\tan x) dx + \int_0^{\frac{\pi}{2}} \log(\cot x) dx$$

$$= \int_0^{\frac{\pi}{2}} [\log \tan x + \log \cot x] dx$$

$$= \int_0^{\frac{\pi}{2}} \log(\tan x \cdot \cot x) dx$$

$$\int_0^{\frac{\pi}{2}} \log(1) dx = \int_0^{\frac{\pi}{2}} 0 dx = 0 \quad \therefore I = 0$$

119. (a)

120. (c) Since, $(e^x + 1) y dy = (y + 1) e^x dx$

$$\Rightarrow \frac{dx}{dy} = \frac{y}{1+y} + \frac{y}{(1+y)e^x}$$

$$\Rightarrow \frac{dx}{dy} = \left(\frac{y}{1+y} \right) \left(\frac{e^x + 1}{e^x} \right)$$

$$\Rightarrow \left(\frac{y}{1+y} \right) dy = \left(\frac{e^x + 1}{e^x} \right) dx$$

After integrating on both sides, we have

$$\int \frac{y}{1+y} dy = \int \frac{e^x}{1+e^x} dx$$

$$\Rightarrow \int 1 dy - \int \frac{1}{1+y} dy = \int \frac{e^x}{1+e^x} dx$$

$$\Rightarrow y - \log|(1+y)| = \log|(1+e^x)| + \log k$$

$$\text{Hence } y = \log[k(1+y)(1+e^x)]$$

121. (c) Equation of parabola is

$$y^2 = 4ax$$

$$\Rightarrow 2y \frac{dy}{dx} = 4a \quad (\text{On differentiating w.r.t 'x'})$$

$$\therefore \frac{dy}{dx} = \frac{2a}{y}, \quad [\text{slope of tangent}]$$

$$\text{So, slope of normal} = - \left(\frac{dx}{dy} \right)_{(at^2, 2at)}$$

$$= - \left(\frac{y}{2a} \right) = - \frac{2at}{2a} = -t$$

122. (a) Let $I = \int_0^{\frac{\pi}{2}} x \sin^2 x \cos^2 x dx \quad \dots(i)$

From the definite integral property

$$\int_0^a f(x) dx = \int_0^a f(a-x) dx$$

we have

$$I = \int_0^{\frac{\pi}{2}} \left(\frac{\pi}{2} - x \right) \sin^2 x \cos^2 x dx \quad \dots(ii)$$

$$\left(\because \cos^2 x = \sin^2 \left(\frac{\pi}{2} - x \right) \text{ \& } \sin^2 x = \cos^2 \left(\frac{\pi}{2} - x \right) \right)$$

By adding (i) and (ii)

$$2I = \frac{\pi}{2} \int_0^{\frac{\pi}{2}} \sin^2 x \cos^2 x dx$$

$$\text{or } 2I = \frac{\pi}{8} \int_0^{\frac{\pi}{2}} \sin^2 2x dx$$

$$[\because \sin 2x = 2 \sin x \cos x]$$

$$= \frac{\pi}{8} \int_0^{\frac{\pi}{2}} (1 - \cos 4x) dx \quad (\because \cos 2\theta = 1 - 2\sin^2 \theta)$$

$$\Rightarrow 2I = \frac{\pi}{8} \left[x - \frac{\sin 4x}{4} \right]_0^{\frac{\pi}{2}}$$

$$\Rightarrow 2I = \frac{\pi}{8} \left[\frac{\pi}{2} - 0 \right] \Rightarrow I = \frac{\pi^2}{32}$$

123. (d)
$$\begin{vmatrix} 6i & -3i & 1 \\ 4 & 3i & -1 \\ 20 & 3 & i \end{vmatrix}$$

$$= 6i [3i^2 + 3] + 3i [4i + 20] + 1 [12 - 60i]$$

$$= 6i [-3 + 3] + 12i^2 + 60i + 12 - 60i$$

$$= -12 + 12 = 0 = x + iy$$

$$\therefore x = 0$$

124. (a)
$$\lim_{x \rightarrow 0} \left\{ \frac{\log_e(1+x)}{x^2} + \frac{x-1}{x} \right\}$$

$$= \lim_{x \rightarrow 0} \frac{\log_e(1+x) + x^2 - x}{x^2}$$

$$= \lim_{x \rightarrow 0} \frac{\left(x - \frac{1}{2}x^2 + \frac{1}{3}x^3 - \dots \right) + x^2 - x}{x^2} = \frac{1}{2}$$

125. (a) $2 \cos^2 x + 3 \sin x - 3 = 0$
 $2 - 2 \sin^2 x + 3 \sin x - 3 = 0$
 $\Rightarrow (2 \sin x - 1)(\sin x - 1) = 0$
 $\Rightarrow \sin x = \frac{1}{2}$ or $\sin x = 1$
 $\Rightarrow x = \frac{\pi}{6}, \frac{5\pi}{6}, \frac{\pi}{2}$, i.e. $30^\circ, 150^\circ, 90^\circ$.

126. (b)

127. (d)
$$y = \tan^{-1} \left(\frac{\sqrt{x} - x}{1 + x^{3/2}} \right) = \tan^{-1} \left(\frac{\sqrt{x} - x}{1 + \sqrt{x} \cdot x} \right)$$

$$= \tan^{-1}(\sqrt{x}) - \tan^{-1}(x)$$

On differentiating w.r.t. x, we get

$$y' = \frac{1}{1+x} \cdot \frac{1}{2\sqrt{x}} - \frac{1}{1+x^2}$$

$$\Rightarrow y'(1) = \frac{1}{2} \cdot \frac{1}{2} - \frac{1}{2} = -\frac{1}{4}$$

128. (b) The diagonal = R
 Thus the area of rectangle

$$= \frac{1}{2} \times R \times R = \frac{R^2}{2}$$

129. (b) From the given problem: $P(A \cup B) = \frac{3}{4}$,

$$P(A \cap B) = \frac{1}{4}$$

$$P(A^c) = \frac{2}{3} = 1 - P(A) \Rightarrow P(A) = 1 - \frac{2}{3} = \frac{1}{3}$$

$$P(A \cup B) = P(A) + P(B) - P(A \cap B)$$

$$\Rightarrow P(B) = P(A \cup B) + P(A \cap B) - P(A)$$

$$= \frac{3}{4} + \frac{1}{4} - \frac{1}{3} = 1 - \frac{1}{3} = \frac{2}{3}$$

130. (b)
$$\lim_{x \rightarrow 0^+} \frac{e^{e/x} - e^{-e/x}}{e^{1/x} + e^{-1/x}}$$

$$= \lim_{x \rightarrow 0^+} \frac{\frac{e-1}{x} (1 - e^{-2e/x})}{(1 + e^{-2/x})} = +\infty$$

$$\lim_{x \rightarrow 0^-} \frac{e^{e/x} - e^{-e/x}}{e^{1/x} + e^{-1/x}} = \lim_{x \rightarrow 0^-} \frac{e^{-e/x} (e^{2e/x} - 1)}{e^{-1/x} (e^{2/x} + 1)}$$

$$= \lim_{x \rightarrow 0^+} e^{-\left(\frac{e-1}{x}\right)} \left(\frac{e^{2e/x} - 1}{e^{2/x} + 1} \right) = -\infty$$

Limit doesn't exist, so f(x) is not continuous at 0.

131. (b) Put $x = \cos \theta$

$$\therefore I = \int \cos \{2 \tan^{-1} \tan \theta\} (-2 \sin 2\theta) d\theta$$

$$= -\int \sin 4\theta d\theta = \frac{1}{4} \cos 4\theta + c$$

$$= \frac{1}{4} (2x^2 - 1) + c = \frac{1}{2} x^2 + k$$

132. (b) $T = S_1 \Rightarrow x(4) + y(3) - 4(x+4) = 16 + 9 - 32$
 $\Rightarrow 3y - 9 = 0 \Rightarrow y = 3$

133. (d) The roots of equation are 2 and 3

$$\therefore g = \sqrt{xy} = 2 \Rightarrow xy = 4$$

$$G = \sqrt{(x+1)(y+1)} = 3 \Rightarrow (x+1)(y+1) = 9$$

$$\therefore x = y = 2$$

134. (c)
$$\frac{e^{7x} + e^x}{e^{3x}} = e^{4x} + e^{-2x}$$

$$= \left[1 + 4x + \frac{(4x)^2}{2!} + \dots \right] + \left[1 + (-2x) + \frac{(-2x)^2}{2!} + \dots \right]$$

$$\therefore \text{coeff. of } x^n = \frac{4^n}{n!} + \frac{(-2)^n}{n!}$$

135. (d) Equation of pair of tangents is given by

$$\begin{aligned} SS_1 &= T^2, \\ \text{or } S &= x^2 + y^2 + 20(x+y) + 20, S_1 = 20, \\ T &= 10(x+y) + 20 = 0 \\ \therefore SS_1 &= T^2 \\ \Rightarrow 20(x^2 + y^2 + 20(x+y) + 20) &= 10^2(x+y+2)^2 \end{aligned}$$

$$\begin{aligned} \Rightarrow 4x^2 + 4y^2 + 10xy &= 0 \\ \Rightarrow 2x^2 + 2y^2 + 5xy &= 0 \end{aligned}$$

136. (c) $a = 25, d = 22 - 25 = -3$.

Let n be the no. of terms

$$\text{Sum} = 116; \text{Sum} = \frac{n}{2}[2a + (n-1)d]$$

$$116 = \frac{n}{2}[50 + (n-1)(-3)]$$

$$\begin{aligned} \text{or } 232 &= n[50 - 3n + 3] = n[53 - 3n] \\ &= -3n^2 + 53n \end{aligned}$$

$$\Rightarrow 3n^2 - 53n + 232 = 0 \Rightarrow (n-8)(3n-29) = 0$$

$$\Rightarrow n = 8 \text{ or } n = \frac{29}{3}, n \neq \frac{29}{3} \therefore n = 8$$

$$\therefore \text{Now, } T_8 = a + (8-1)d = 25 + 7 \times (-3) = 25 - 21$$

$$\therefore \text{Last term} = 4$$

137. (d) $2a = 1 + P$ and $g^2 = P$

$$\Rightarrow g^2 = 2a - 1 \Rightarrow 1 - 2a + g^2 = 0$$

138. (b) $y = \sin x = e^x$

$$\Rightarrow \frac{dy}{dx} = \cos x + e^x$$

$$\Rightarrow \frac{dx}{dy} = \frac{1}{\cos x + e^x} \quad \dots(i)$$

$$\therefore \frac{d^2x}{dy^2} = -\frac{1}{(\cos x + e^x)^2} [-\sin x + e^x] \frac{dx}{dy}$$

$$= -\frac{(e^x - \sin x)}{(\cos x + e^x)^2} \times \frac{1}{\cos x + e^x}$$

$$= \frac{-(e^x - \sin x)}{(\cos x + e^x)^3} = \frac{\sin x - e^x}{(\cos x + e^x)^3}$$

139. (b) $4x^2 - 9y^2 = 1$

$$\frac{x^2}{\left(\frac{1}{2}\right)^2} - \frac{y^2}{\left(\frac{1}{3}\right)^2} = 1$$

$$\text{eccentricity, } e = \sqrt{1 + \frac{\left(\frac{1}{3}\right)^2}{\left(\frac{1}{2}\right)^2}} = \frac{\sqrt{13}}{3}$$

$$\text{foci} = \left(\pm \frac{1}{2} \times \frac{\sqrt{13}}{3}, 0\right) = \left(\pm \frac{\sqrt{13}}{6}, 0\right)$$

140. (d) Let height of the tower be h m and distance between tower and cliff be x m.

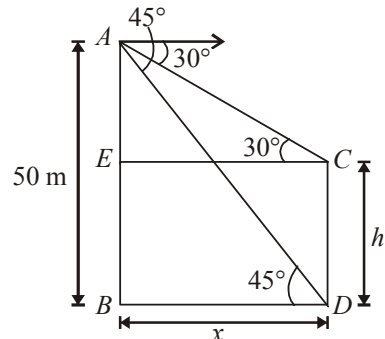

$$\therefore CD = h, BD = x$$

$$\text{In } \triangle ABD, \tan 45^\circ = \frac{AB}{BD} \text{ or } 1 = \frac{50}{x}$$

$$x = 50 \quad \dots(i)$$

In $\triangle AEC$

$$\tan 30^\circ = \frac{AE}{EC} = \frac{AB - EB}{EC} = \frac{AB - DC}{BD}$$

$$(\because EB = DC, EC = BD)$$

$$\frac{1}{\sqrt{3}} = \frac{50 - h}{x} \text{ or } x = 50\sqrt{3} - h\sqrt{3}$$

$$\text{or } 50 = 50\sqrt{3} - h\sqrt{3} \quad [\text{From (i), } x = 50]$$

$$\text{or } h\sqrt{3} = 50\sqrt{3} - 50$$

$$\text{or } h = \frac{50(\sqrt{3} - 1)}{\sqrt{3}} = 50\left(1 - \frac{1}{\sqrt{3}}\right)$$

$$\therefore h = 50\left(1 - \frac{\sqrt{3}}{3}\right)$$

141. (a) General term of the given binomial series is given by:

$$T_{r+1} = {}^{10}C_r \left\{ \frac{x^{1/2}}{3} \right\}^{10-r} \cdot \{x^{-1/4}\}^r$$

Put $r = 4$, we get

$$T_5 = {}^{10}C_4 \cdot \frac{1}{3^6} x^3 \cdot x^{-1}$$

$$= \frac{10 \times 9 \times 8 \times 7}{4 \times 3 \times 2 \times 1} \cdot \frac{1}{3^6} x^2 = \frac{70}{243} x^2$$

Thus coefficient of $x^2 = \frac{70}{243}$.

- 142. (c)** Two circles $x^2 + y^2 + 2g_1x + 2f_1y + c_1 = 0$ and $x^2 + y^2 + 2g_2x + 2f_2y + c_2 = 0$ cuts orthogonally if $2g_1g_2 + 2f_1f_2 = c_1 + c_2$

Given equations of two circles are

$$x^2 + y^2 + 2\lambda x + 6y + 1 = 0 \quad \dots (i)$$

$$x^2 + y^2 + 4x + 2y = 0 \quad \dots (ii)$$

On comparing (i) and (ii) with original equation, we get

$$g_1 = \lambda, f_1 = 3, c_1 = 1 \text{ and } g_2 = 2, f_2 = 1, c_2 = 0$$

So, from orthogonality condition, we have

$$4\lambda + 6 = 1 \Rightarrow 4\lambda = -5$$

$$\therefore \lambda = \frac{-5}{4}$$

- 143. (a)** We know, scalar triple product

$$[\vec{a} \vec{b} \vec{c}] = \vec{a} \cdot (\vec{b} \times \vec{c}) \equiv (\vec{a} \times \vec{b}) \cdot \vec{c}$$

Consider $[\vec{a} + \vec{b} \vec{b} + \vec{c} \vec{c} + \vec{a}]$

$$= (\vec{a} + \vec{b}) \cdot \{(\vec{b} + \vec{c}) \times (\vec{c} + \vec{a})\}$$

$$= (\vec{a} + \vec{b}) \cdot \{(\vec{b} \times \vec{c}) + (\vec{b} \times \vec{a}) + (\vec{c} \times \vec{c}) + (\vec{c} \times \vec{a})\}$$

$$= (\vec{a} + \vec{b}) \cdot \{(\vec{b} \times \vec{c}) + (\vec{b} \times \vec{a}) + (\vec{c} \times \vec{a})\}$$

$$(\because \vec{c} \times \vec{c} = 0)$$

$$= \vec{a} \cdot (\vec{b} \times \vec{c}) + \vec{a} \cdot (\vec{b} \times \vec{a}) + \vec{a} \cdot (\vec{c} \times \vec{a})$$

$$+ \vec{b} \cdot (\vec{b} \times \vec{c}) + \vec{b} \cdot (\vec{b} \times \vec{a}) + \vec{b} \cdot (\vec{c} \times \vec{a})$$

$$= [\vec{a} \vec{b} \vec{c}] + [\vec{a} \vec{b} \vec{a}] + [\vec{a} \vec{c} \vec{a}] + [\vec{b} \vec{b} \vec{c}]$$

$$+ [\vec{b} \vec{b} \vec{a}] + [\vec{b} \vec{c} \vec{a}]$$

(By definition of scalar triple product)

$$[\vec{a} \vec{a} \vec{b}] = 0, [\vec{a} \vec{b} \vec{a}] = 0 \text{ and } [\vec{b} \vec{a} \vec{a}] = 0$$

$$= [\vec{a} \vec{b} \vec{c}] + [\vec{b} \vec{c} \vec{a}] = 2 [\vec{a} \vec{b} \vec{c}]$$

- 144. (b)** Given that $f(x) = (a - x^n)^{1/n}$

$$\therefore \text{fof}(x) = [a - \{(a - x^n)^{1/n}\}^n]^{1/n}$$

$$= [a - (a - x^n)]^{1/n}$$

$$= [x^n]^{1/n} = x$$

- 145. (a)** Sum = $\frac{8}{9} [9 + 99 + 999 + \dots n \text{ terms}]$

$$= \frac{8}{9} [(10-1) + (100-1) + (1000-1) + \dots n \text{ terms}]$$

$$= \frac{8}{9} [(10 + 10^2 + 10^3 + \dots + 10^n) - n]$$

$$= \frac{8}{9} \left[\frac{10(10^n - 1)}{10 - 1} - n \right]$$

$$= \frac{8}{81} [10^{n+1} - 9n - 10]$$

- 146. (a)** Let $z = x + iy$

$$\therefore |z + 3 - i| = |(x + 3) + i(y - 1)| = 1$$

$$\Rightarrow \sqrt{(x + 3)^2 + (y - 1)^2} = 1 \quad \dots (i)$$

$$\therefore \arg z = \pi \Rightarrow \tan^{-1} \frac{y}{x} = \pi$$

$$\Rightarrow \frac{y}{x} = \tan \pi = 0 \Rightarrow y = 0 \quad \dots (ii)$$

From equations (i) and (ii), we get

$$x = -3, y = 0 \therefore z = -3$$

$$\Rightarrow |z| = |-3| = 3$$

- 147. (b)** Let E_1, E_2 and A be the events defined as follows:

E_1 = red ball is transferred from bag P to bag Q

E_2 = blue ball is transferred from bag P to bag Q

A = the ball drawn from bag Q is blue

As the bag P contains 6 red and 4 blue balls,

$$P(E_1) = \frac{6}{10} = \frac{3}{5} \text{ and } P(E_2) = \frac{4}{10} = \frac{2}{5}$$

Note that E_1 and E_2 are mutually exclusive and exhaustive events.

When E_1 has occurred i.e., a red ball has already been transferred from bag P to Q, then bag Q will contain 6 red and 6 blue

balls, So, $P(A|E_1) = \frac{6}{12} = \frac{1}{2}$

When E_2 has occurred i.e., a blue ball has already been transferred from bag P to Q, then bag Q will contain 5 red and 7 blue

balls, So, $P(A|E_2) = \frac{7}{12}$

By using law of total probability, we get $P(A) = P(E_1)P(A|E_1) + P(E_2)P(A|E_2)$

$$= \frac{3}{5} \times \frac{1}{2} + \frac{2}{5} \times \frac{7}{12} = \frac{8}{15}$$

- 148. (a)** Total number of 4-digit numbers
 $= 5 \times 5 \times 5 \times 5 = 625$
 (as each place can be filled by anyone of the numbers 1, 2, 3, 4 and 5)

Numbers in which no two digits are identical

$$= 5 \times 4 \times 3 \times 2 = 120 \text{ (i.e. repetition not allowed)}$$

(as 1st place can be filled in 5 different ways, 2nd place can be filled in 4 different ways and so on)

Number of 4-digits numbers in which at least 2 digits are identical

$$= 625 - 120 = 505$$

149. (c) $D = \begin{vmatrix} 1 & 2 & 1 \\ 2 & 3 & 1 \\ 3 & 5 & 2 \end{vmatrix} = 0$; $D_1 = \begin{vmatrix} 3 & 2 & 1 \\ 3 & 3 & 1 \\ 1 & 5 & 2 \end{vmatrix} \neq 0$

\Rightarrow Given system, does not have any solution.

\Rightarrow No solution

- 150. (d)** Let A(3, y), B(2, 7), C(-1, 4) and D(0, 6) be the given points.

$$m_1 = \text{slope of AB} = \frac{7-y}{2-3} = (y-7)$$

$$m_2 = \text{slope of CD} = \frac{6-4}{0-(-1)} = 2$$

Since AB and CD are parallel. $\therefore m_1 = m_2 \Rightarrow y = 9$.